



NerveCenter

Managing NerveCenter

**UNIX and Windows
Version 4.1.03**

Copyright

Portions ©1989-2008 OpenService, Inc. All rights reserved.

Disclaimers

OpenService, Inc. (“OpenService”, “Open”) makes no representations or warranties, either expressed or implied, by or with respect to anything in this manual, and shall not be liable for any implied warranties of merchantability or fitness for a particular purpose or for any indirect, special or consequential damages.

These applications are available through separate, individual licenses. Not every feature or application described herein is licensed to every customer. Please contact OpenService if you have licensing questions.

No part of this publication may be reproduced, stored in a retrieval system or transmitted, in any form or by any means, photocopying, recording or otherwise, without prior written consent of OpenService. While every precaution has been taken in the preparation of this book, OpenService assumes no responsibility for errors or omissions. This publication and the features described herein are subject to change without notice.

The program and information contained herein are licensed only pursuant to a license agreement that contains use, reverse engineering, disclosure and other restrictions.

Trademarks

OpenService is registered in the U.S. Patent and Trademark Office. Security Threat Manager, NerveCenter, and the Open Logo are trademarks of OpenService, Inc.

All other products or services mentioned in this manual may be covered by the trademarks, service marks, or product names as designated by the companies who market those products.

OpenService, Inc.
67 Forest Street
Marlborough, MA 01752
Phone 508-597-5300
Fax 508-597-5399
<http://www.openservice.com>

1 Introduction

Overview of this Book	2
NerveCenter Documentation	4
Using the Online Help	4
Printing the Documentation	4
The NerveCenter Documentation Library	5
UNIX Systems	6
Document Conventions	6
Documentation Feedback	8
OpenService Technical Support	8
Professional Services	8
Educational Services	8
Contacting the Customer Support Center	8
For Telephone Support	8
For E-mail Support	9
For Electronic Support	9
For Online KnowledgeBase Access	9

2 Understanding NerveCenter

NerveCenter Overview	12
How NerveCenter Correlates Events	13
How NerveCenter Manages Nodes	14
How Behavior Models Work	15
Behavior Model Objects	15
Behavior Model Operation	16
How Properties Affect Behavior Models	17
Other Trigger Generators	17
Alarm Actions	18
Alarms	18
NerveCenter Components	21
NerveCenter Server	21
NerveCenter Database	21

NerveCenter MIB	22
NerveCenter Interfaces	23
The NerveCenter Administrator	24
The NerveCenter Client Console	25
The NerveCenter Client	26
The NerveCenter Web Client	27
The Command Line Interface	28
Role in Network Management Strategy	29
Standalone Operation	30
Using Multiple NerveCenter Servers	31
Integration with Network Management Platforms	32
3 Administering NerveCenter	
Who Uses NerveCenter?	34
NerveCenter Login Rights	35
The Role of a NerveCenter Administrator	36
4 Running the NerveCenter Server	
Running the NerveCenter Server on UNIX	38
Running the NerveCenter Server on Windows	39
Troubleshooting: Running the NerveCenter Server	40
5 Connecting to a NerveCenter Server	
Starting NerveCenter Administrator	42
Starting the NerveCenter Administrator on UNIX	42
Starting the NerveCenter Administrator on Windows	43
Connecting Administrator to a NerveCenter Server	44
Connecting Administrator to Multiple NerveCenter Servers	46
Deleting a Name from the Administrator's Server List	47
Viewing NerveCenter Server Status	48
Disconnecting the Administrator from a NerveCenter Server	50
Troubleshooting: Connecting to the NerveCenter Server	51
6 Managing the NerveCenter Server	
Managing the NerveCenter Trap Source	54
Trap Source Overview	54
NerveCenter Trap Utilities	55

Trapgen	55
Trapcv	55
Changing the SNMP Trap Source	56
Working with NerveCenter Serial Numbers	62
Adding a Serial Number to a NerveCenter Server	63
Deleting an Old Serial Number from a NerveCenter Server	64
NerveCenter Rules for Managing Serial Numbers	65
Reconfiguring a NerveCenter Server from the Command Line	66
Troubleshooting: Managing the NerveCenter Server	78

7 Managing NerveCenter Port Settings

NerveCenter's Client/Server Communication Port	80
Configuring the NerveCenter Server Connection Port	80
Changing the NerveCenter Administrator's Server Port	82
Changing the NerveCenter Client's Server Port	83
Configuring NerveCenter to Receive Inform Actions	84
Changing the Command Line Interface Port	86
Specifying SNMP Ports for NerveCenter	88
Troubleshooting: Managing NerveCenter Port Connections	90

8 Managing Node Data

How NerveCenter Manages Nodes	92
Defining a Set of Nodes	92
Detecting Conditions	93
Correlating Conditions	93
Detecting the Persistence of a Condition	94
Finding a Set of Conditions	95
Looking for a Sequence of Conditions	96
Responding to Conditions	98
Notification	99
Logging	99
Causing State Transitions	100
Corrective Actions	100
Action Router	101
NerveCenter's Node List	102
Filtering Nodes	103
Filtering Using a Node's Capabilities	103
Filtering Using a Node's System Object Identifier	104
Filtering Nodes by IP Address	105

Filtering Nodes by Hostnames	110
Enabling and Disabling IP and Hostname Filters	111
Processing Traps from Unknown Nodes	113
Initially Populating the Node List	115
Populating Using a Network Management Platform as a Data Source	117
Populating Using the IPSweep Behavior Model	119
Populating the Node List Manually	122
Maintaining the Node List	123
Synchronization with Your Network Management Platform	124
Adding Nodes Discovered from Traps	125
Adding and Deleting Nodes Manually	127
Troubleshooting: Managing node data	129

9 Managing SNMP Settings

Overview of NerveCenter SNMP v3 Support	134
NerveCenter Support for SNMP v3 Security	136
NerveCenter Support for SNMP v3 Digest Keys and Passwords	137
The Need for Node Classification	138
NerveCenterNode Classification Algorithm	139
How NerveCenter Classifies a Node	140
SNMP Auto and Manual Classification Settings	141
How NerveCenter Classifies a Node's SNMP Version	141
When NerveCenter Classifies a Node's SNMP Version	142
Classifying Nodes Automatically	143
Setting a Maximum Classify Value	145
Performance Tuning for Node Classification	146
Setting the Maximum SNMP v3 Requests per Cycle	146
Specifying SNMP Poll Intervals for NerveCenter	147
Specifying SNMP Ports for NerveCenter	149
Discovery and Initialization of SNMP v3 Agents	150
Configuring an SNMP v3 Agent for NerveCenter	151
Configuring an Initial User for Discovering an SNMP v3 Agent	154
SNMP v3 Security Settings	155
Changing the SNMP v3 Key Passwords	155
Changing the NerveCenter SNMP v3 User Name and Context	157
SNMP v3 Operations Log	159
Signing a Log for SNMP v3 Errors Associated with Your Administrator	160
Signing a Log for SNMP v3 Errors Associated with a Remote Client or Administrator	161
Viewing the SNMP v3 Operations Log	163
SNMP Error Status	164

SNMP Agent	167
10 Managing NerveCenter Security	
Managing Security on UNIX	172
Managing Security on Windows	172
Adding Users to a NerveCenter on a Windows Workstation or Server	173
Adding Users to a NerveCenter on a Windows Domain Controller	175
Working with Active Directory	177
Troubleshooting: Managing NerveCenter Security	179
11 Managing NerveCenter Alarm Actions	
Specifying an SMTP Server for Mail Notification	182
Configuring NerveCenter to Send Microsoft Mail	184
Configuring NerveCenter to Send Microsoft Mail While Running as a Service	185
Configuring NerveCenter to Send Microsoft Mail while Running the Server as a Process	188
Setting Dialing Properties for Paging Notification on Windows	190
Setting Dialing Properties for Paging Notification on UNIX	192
Specifying Settings for Log Management	194
Troubleshooting: Managing Alarm Actions	197
12 Managing NerveCenter Web Integration	
How to Start and Stop the NerveCenter Web Collector	199
Starting and Stopping the NerveCenter Web Collector in UNIX	200
Starting and Stopping the NerveCenter Web Collector in Windows	200
Configuring a Web Server for NerveCenter	201
Configuring Internet Information Server	202
Configuring an Apache Web Server	205
13 Managing the Database	
Database Formats	208
Viewing Information about the Database	209
NerveCenter Database Utilities	210
UNIX	211
Windows	212
Backing up the Database	213
Restoring the Database	217
Restoring the Database Using the SerializeDB Application	217

Restoring the Database from the Command Line	219
Transferring Data between Databases	221
ncdb2html.pl	222
Troubleshooting: Managing the NerveCenter Database	227
14 Managing Management Information Bases (MIBs)	
Sources of MIB Definitions	230
Definitions Compiled into the NerveCenter MIB	230
Definitions Not Compiled into the NerveCenter MIB	231
Definitions from other sources	232
Adding or Removing MIB Definitions	232
Compiling the NerveCenter MIB	235
Configuring NerveCenter to Use the New MIB	237
Troubleshooting: Managing MIBs	239
A Error Messages	
User Interface Messages	243
Error Messages	245
Action Manager Error Messages	246
Alarm Filter Manager Error Messages	251
Deserialize Manager Error Messages	251
Flatfile Error Messages	252
Inform NerveCenter Error Messages	252
Inform OV Error Messages	252
LogToDatabase Manager Error Messages	255
LogToFile Manager Error Messages	256
OpC Manager Error Messages	256
Poll Manager Error Messages	257
Protocol Manager Error Messages	257
PA Resync Manager Error Messages	258
Server Manager Error Messages	260
Trap Manager Error Messages	265
NerveCenter installation Error Messages (UNIX)	266
OpenView Configuration Error Messages (UNIX)	269
B Troubleshooting NerveCenter	
Common problems	271
The NerveCenter Server	271

NerveCenter's node list	272
Alarm actions	272
The NerveCenter database	273
Management Information Bases (MIBs)	273
Using Trace Counters to Troubleshoot NerveCenter	273
Using Trace Counters	275
Resetting counters	275
Refreshing the Trace Counter display	276
Alarm Action Counters	277
Database Counters	277
Inform Counters	278
Inform NerveCenter Counters	278
Log to Database Counters	279
Log to File Counters	279
Server Counters	280
Node Source Counters	280
OPC Msg Counters	281
Poll Counters	281
Trap Counters	282
Trigger Counters	282
Troubleshooting ASN.1 files	283
Use of characters	283
Period, underscore, and hyphen	284
Capitalization	284
Table construction	286
Duplicate type definitions	288
Object identifier format	288
Ignored IMPORT definitions	288

C Controlling NerveCenter from the Command Line

NerveCenter Command Line Interface	289
Entering a Single Command in a UNIX Shell or a DOS Prompt	290
Entering Multiple Commands in an Interactive Session	291
Running a script that contains one or more commands	292
NerveCenter UNIX Shell/DOS Prompt Commands	294
client	295
dbwizard	295
importutil	296
installdb	306
ipsweep	308



Contents

- mibcomp 310
- ncadmin 312
- nccmd. 312
- ncserver 314
- ncstart. 315
- ncstop. 316
- ovpa 317
- paserver 321
- semsopca 324
- serializedb 325
- trapgen 326
- Traprcv. 330
- Command Line Interface Reference 331
 - Server commands 331
 - Object commands 334
 - General commands 336
 - Notes for CLI commands 337
 - CLI command examples 337

- Index** 357

Welcome to *Managing NerveCenter*. This chapter introduces the audience and purpose of this guide, and how you can best use it.

This chapter includes the following sections:

Section	Description
<i>Overview of this Book on page 2</i>	Includes an overview of the contents of this guide and what you need to know before you use the guide.
<i>NerveCenter Documentation on page 4</i>	Lists and describes the components of the OpenService NerveCenter support system, including printed guides, online guides, help, and links to the OpenService NerveCenter Web site and the OpenService technical support Web site.
<i>OpenService Technical Support on page 8</i>	Describes how to access the NerveCenter knowledge base and other OpenService support services.

Overview of this Book

Managing NerveCenter describes how NerveCenter works and how you can monitor your network most effectively. This book is written for users operating the NerveCenter Client and the NerveCenter Web Client.

Managing NerveCenter contains the following chapters:

Title	Description
<i>Chapter 2, Understanding NerveCenter</i>	Explains what the NerveCenter components do, how NerveCenter manages nodes, and how it can fit into a network management strategy.
<i>Chapter 3, Administering NerveCenter</i>	Describes the different types of NerveCenter users, their privileges, and how to administer them.
<i>Chapter 4, Running the NerveCenter Server</i>	Explains how to start and stop the NerveCenter server on Windows and UNIX platforms.
<i>Chapter 6, Managing the NerveCenter Server</i>	Explains how to manage NerveCenter traps and serial numbers, and how to control NerveCenter from a command line.
<i>Chapter 7, Managing NerveCenter Port Settings</i>	Describes how to configure NerveCenter communication, CLI, and SNMP ports.
<i>Chapter 5, Connecting to a NerveCenter Server</i>	Explains how to connect a NerveCenter Administrator to a NerveCenter Server, view server status, and troubleshoot connections.
<i>Chapter 8, Managing Node Data</i>	Explains how NerveCenter automates event handling; how it stores, filters, and processes node data; how to add and remove nodes; and how to troubleshoot node management.
<i>Chapter 9, Managing SNMP Settings</i>	Describes in detail how to configure NerveCenter for SNMP communication and support SNMP v3 agents.
<i>Chapter 10, Managing NerveCenter Security</i>	Explains how to manage security on UNIX and Windows.
<i>Chapter 11, Managing NerveCenter Alarm Actions</i>	Explains how to configure mail notification, dialing and paging properties, and log management settings for alarm actions.
<i>Chapter 12, Managing NerveCenter Web Integration</i>	Explains how to start and stop the NerveCenter Web Collector for web integration, and how to configure the web server.
<i>Chapter 13, Managing the Database</i>	Describes the NerveCenter database utilities, how to back up and restore the database, and how to transfer data between databases.

Title	Description
<i>Chapter 14, Managing Management Information Bases (MIBs)</i>	Describes the pre-compiled definitions in the NerveCenter MIB, how to add or remove definitions, and how to compile and troubleshoot the MIB.
<i>Appendix A, Error Messages</i>	Lists various types of NerveCenter error messages and the steps you can take to resolve them.
<i>Appendix B, Troubleshooting NerveCenter</i>	Describes how to troubleshoot common NerveCenter server problems.
<i>Appendix C, Controlling NerveCenter from the Command Line</i>	Describes how to control NerveCenter using its command line interface (CLI).

NerveCenter Documentation

This section describes the available NerveCenter documentation, which explains important concepts in depth, describes how to use NerveCenter, and provides answers to specific questions.

The documentation set is provided in online (HTML) format, as well as PDF for printing or on-screen viewing. See the following topics for more information:

- ◆ *Using the Online Help on page 4*
- ◆ *Printing the Documentation on page 4*
- ◆ *The NerveCenter Documentation Library on page 5*
- ◆ *UNIX Systems on page 6*
- ◆ *Document Conventions on page 6*
- ◆ *Documentation Feedback on page 8*

Using the Online Help

You can use Microsoft Internet Explorer, Mozilla, or Netscape Navigator to view the documentation. Refer to the *NerveCenter 4.1.03 Release Notes* for the browser versions supported with this release.

 **TIP**

For in-depth instructions on using the online documentation, click the Help button  in the upper right of the Help window.

Printing the Documentation

The NerveCenter documentation is also available as Portable Document Format (PDF) files that you can open and print. All PDF files are located in your *installpath/doc* directory.

 **NOTE**

You must have Adobe Acrobat Reader to open or print the PDF files. You can download the Reader free from Adobe's Web Site at <http://www.adobe.com>.

The NerveCenter Documentation Library

The following documents ship with NerveCenter.

Book Title	Description	Application	Audience	PDF for Print
<i>NerveCenter 4.1.03 Release Notes</i>	Describes new NerveCenter features and includes late-breaking information, software support, corrections, and instructions.	All	All	relnotes.pdf
<i>Getting a Quick Start with NerveCenter</i>	Provides a preview prior to installing and configuring NerveCenter for your network. Takes approximately one to two hours to complete.	All	New users	QuickStart.pdf
<i>Upgrading NerveCenter</i>	Explains how to upgrade your current NerveCenter version.	All	Installation team	upgrading.pdf
<i>Installing NerveCenter</i>	Helps you plan and carry out your NerveCenter installation. Use the <i>Release Notes</i> in conjunction with this book.	All	Installation team	install.pdf
<i>Managing NerveCenter</i>	Explains how to customize and tune NerveCenter after it has been installed.	NerveCenter Administrator	Administrator	managing_nervecenter.pdf
<i>Integrating NerveCenter with a Network Management Platform</i>	Explains how to integrate NerveCenter with network management platforms.	NerveCenter Administrator	Administrator	integratingNC.pdf
<i>Learning How to Create Behavior Models</i>	Provides step-by-step instructions and examples for creating behavior models.	NerveCenter Client	Users with administrative privileges	learningModel.pdf
<i>Designing and Managing Behavior Models</i>	Explains behavior models in depth, how to create or modify models, and how to manage your models.	NerveCenter Client	Users with administrative privileges	designingModels.pdf
<i>Monitoring Your Network</i>	Explains how NerveCenter works and how you can most effectively monitor your network.	NerveCenter Client and Web Client	Users	monitoringNet.pdf

Book Title	Description	Application	Audience	PDF for Print
<i>Behavior Models Cookbook</i>	Describes each behavior model shipped with OpenService NerveCenter.	NerveCenter Client	Users with administrative privileges	modsCookbook.pdf
Quick reference cards	Quick reference cards provide convenient reference material for common NerveCenter tasks. The following cards are provided (PDF only): <ul style="list-style-type: none"> ◆ Monitoring NerveCenter reference. ◆ Installing NerveCenter reference. ◆ Using Behavior Models reference. 	NerveCenter Client and Administrator	All	quickreference.pdf

UNIX Systems

On UNIX systems, NerveCenter man pages provide command reference and usage information that you view from the UNIX shell as with other system man pages. When you specify documentation during NerveCenter installation, the script installs nroff-tagged man pages and updates your system's MANPATH environment variable to point to the NerveCenter man page directory.

Document Conventions

This document uses the following typographical conventions:

Element	Convention	Example
Key names, button names, menu names, command names, and user entries	Bold	Press Tab Enter ovpa -pc
<ul style="list-style-type: none"> ◆ A variable you substitute with a specific entry ◆ Emphasis ◆ Heading or Publication Title 	<i>Italic</i>	Enter <i>./installdb -f IDBfile</i>

Element	Convention	Example
Code samples, code to enter, or application output	Code	<code>iifInOctets > 0</code>
Messages in application dialog boxes	Message	Are you sure you want to delete?
An arrow (>) indicates a menu selection	>	Choose Start > Programs > OpenService NerveCenter
A link to a section in the same book	<i>Blue Italic</i>	For more information, see <i>Correlating Conditions</i> .
A link to a section in a different book	<i>Green Italic</i>	For more information, see <i>Correlating Conditions</i> in <i>Monitoring Your Network with NerveCenter</i> .
<p>Note: If you are viewing this document in a PDF viewer, you may need to use the Go to Previous View button to return to the original PDF file.</p>		

**CAUTION**

A caution warns you if a procedure or description could lead to unexpected results, even data loss, or damage to your system. If you see a caution, proceed carefully.

**NOTE**

A note provides additional information that might help you avoid problems, offers advice, and provides general information related to the current topic.

**TIP**

A tip provides extra information that supplements the current topic. Often, tips offer shortcuts or alternative methods for accomplishing a task.



If toolbar buttons are available, they are displayed in the margin next to the step in which you can use them. Other shortcuts are noted as tips. Also, shortcut (accelerator) keys are displayed on application menus next to their respective options.

Documentation Feedback

OpenService, Inc. is committed to providing quality documentation and to helping you use our products to the best advantage. If you have any comments or suggestions, please send your documentation feedback to:

Documentation
OpenService, Inc.
67 Forest Street
Marlborough, MA 01752

documentation@openservice.com

OpenService Technical Support

OpenService is committed to offering the industry's best technical support to our customers and partners. You can quickly and easily obtain support for NerveCenter, our proactive network management software, or SMC, our security threat management suite.

Professional Services

OpenService offers professional services when customization of our software is the best solution for a customer. These services enable us, in collaboration with our partners, to focus on technology, staffing, and business processes as we address a specific need.

Educational Services

OpenService is committed to providing ongoing education and training in the use of our products. Through a combined set of resources, we can offer quality classroom style or tailored on-site training.

Contacting the Customer Support Center

For Telephone Support

Phone: 1-800-892-3646 or 1-508-597-5300

For E-mail Support

E-mail: techsupport@openservice.com.

For Electronic Support

OpenService has a Web-based customer call tracking system where you can enter questions, log problems, track the status of logged incidents, and check the knowledge base.

When you purchased your product and/or renewed your maintenance contract, you would have received a user name and password to access the OpenService Call Tracking System using TeamShare. You may need to contact your contracts or NerveCenter administrator for the username and password for your account with TeamShare.

If you have not received or have forgotten your log-in credentials, please e-mail us with a contact name and company specifics at techsupport@openservice.com.

We are committed to providing ongoing education and training in the use of our products. Through a combined set of resources, we offer quality training to our global customer base.

For Online KnowledgeBase Access

For additional NerveCenter support information, please go the OpenService website <http://www.openservice.com> for access to the following sections of information:

- ◆ **Patches and Updates** - latest installation files, patches, and updates including documentation for NerveCenter.
- ◆ **Software Alerts** - latest software alerts relative to NerveCenter.
- ◆ **KnowledgeBase Search** - search the NerveCenter KnowledgeBase for answers to your questions whether relating to the installation, usage, or operation of NerveCenter.

NerveCenter™ is an application designed to monitor, manage, and automate events in complex heterogeneous networks. Through a process called event correlation, NerveCenter helps you track significant events, quickly identify the root cause of critical network problems, and initiate corrective actions. This chapter explains the core NerveCenter functionality, describes the main NerveCenter components, and explains how these they interact with each other.

This chapter contains the following sections:

Section	Description
<i>NerveCenter Overview on page 12</i>	Introduces NerveCenter and provides an overview of how it uses behavior models to detect important network events and track device status.
<i>How NerveCenter Correlates Events on page 13</i>	Introduces how NerveCenter polls and alarms play a role in identifying important network events.
<i>How NerveCenter Manages Nodes on page 14</i>	Introduces how NerveCenter isolates and responds to emerging network and system problems.
<i>How Behavior Models Work on page 15</i>	Introduces the objects that make up behavior models and describes how they interact.
<i>NerveCenter Components on page 21</i>	Introduces the primary NerveCenter components.
<i>Role in Network Management Strategy on page 29</i>	Introduces how NerveCenter can operate from a central stand-alone server, as a distributed system on multiple servers, or as a component integrated with other products.

NerveCenter Overview

There are many management tools designed to identify network faults and send alerts. However, these tools often flood the event console with events and network data. Each critical or warning message indicating a possible problem is usually accompanied by many additional messages — if a router fails, for example, the console receives many events concerning machines behind the router that cannot be contacted. Consoles also receive many messages about normal events such as simple power-up operations. As a result, there is a great deal of information to sift through before the real problem can be identified and corrected.

NerveCenter is a network management tool that helps automate the identification, tracking, management, and resolution of important network events. NerveCenter uses the Simple Network Management Protocol (SNMP) to acquire data about managed devices. NerveCenter also relies on Internet Control Message Protocol (ICMP) messages from your network to provide basic information about unresponsive devices.

At the heart of NerveCenter is the event correlation engine. NerveCenter greatly reduces the volume of event data by intelligently interpreting and correlating raw network data to determine whether a problem is serious enough to warrant human intervention. NerveCenter can then take automatic corrective action to solve the problem, inform the management platform, or notify the appropriate person.

For each device that NerveCenter monitors, it creates one or more finite state machines—or alarms—that define operational states that it wants to detect, and defines rules that affect transitions between operational states. These rules can be very simple; for example, a state transition can be caused by the receipt of a generic Simple Network Management Protocol (SNMP) trap. Or they can be quite complex and take advantage of NerveCenter's support for Perl expressions.

In addition to being an advanced event automation solution, NerveCenter is a highly scalable, cross-platform client/server application. It can run co-resident with a network management platform (such as Hewlett Packard's OpenView Network Node Manager) and manage thousands of nodes, or the server can run as a background process at tens or even hundreds of remote offices.

How NerveCenter Correlates Events

NerveCenter obtains data from SNMP agents running on managed nodes by processing incoming SNMP traps and polling the nodes for specific MIB values using SNMP Get requests. When a predefined network condition is detected, NerveCenter stores the event information in a finite state machine called an alarm. The alarm continues to track the status of the interface, node, or enterprise being monitored. The alarm waits for subsequent events or issues polls to determine if the condition warrants further action.

For example, by tracking events based on their persistence, NerveCenter can detect when a router experiences a persistent link-down condition. Upon detecting a downed communication link, NerveCenter waits to see if the link is restored within a given amount of time. If the link comes back up within the specified time, NerveCenter acknowledges the situation and returns the alarm to its normal (ground) state. However, if the link remains down, NerveCenter can perform a variety of actions based on your management strategy. Also, NerveCenter can detect when a group of nodes appears to be down or unreachable and then poll their parent router. If the router is down, further polling of those nodes is disabled until the router is back up.

To correlate and filter this data, NerveCenter relies on configurable network and system behavior models for each type of managed resource. A behavior model is a group of NerveCenter objects that detect and handle a particular network or system behavior. A typical behavior model consists of an alarm with its supporting polls and masks, though behavior models can have multiple alarms. Any managed device can be associated with one or more behavior models. For a description of behavior models, see [How Behavior Models Work on page 15](#).

Once a NerveCenter behavior model has identified a problem, it can take automatic actions, including notifying an administrator or a network management platform, executing a program or script, modifying the node's properties, changing SNMP values, and logging the critical data.

How NerveCenter Manages Nodes

To automate events, NerveCenter relies on the definition of *behavior models*. These models are constructed from NerveCenter objects and define:

- ◆ Which devices, or nodes, a behavior model will affect
- ◆ How NerveCenter will detect certain conditions on these nodes
- ◆ How NerveCenter will correlate the conditions it detects
- ◆ How NerveCenter will respond to network problems

NerveCenter can get the list of nodes to monitor from a network management platform, discover them on the network, or import the information from another NerveCenter database. NerveCenter most often obtains data from SNMP (Simple Network Management Protocol) agents running on managed nodes.

NerveCenter assigns a set of properties to each managed node that determine the behavior models that can be applied. Properties typically describe the type of the device—for example, a router—or are named after objects in the management information base (MIB) used to manage the node.

After gathering data, the NerveCenter correlation engine examines detected network conditions and determines how the conditions may be related, or the underlying cause that produced the conditions. Detected conditions can be correlated in many ways, which include detecting the persistence of a condition, finding a set of conditions, and looking for a sequence of conditions. For instance, NerveCenter may scan a large number of events and identify a subset that relate to SNMP authentication failures on a managed node. NerveCenter may then determine that the authentication failures were far enough apart that no problem exists, or it may find that several failures occurred within a short period of time — which may indicate a possible security problem.

NerveCenter not only enables you to detect network and system problems, but is able to respond automatically to the conditions it detects. To set up these automated responses, you associate *actions* with state transitions. For example, NerveCenter can notify an administrator via email or pager, log the information to a file, trigger a transition in another alarm, or execute a script.

For more information on nodes, see [Chapter 8, Managing Node Data](#).

How Behavior Models Work

NerveCenter detects events and compares these events to conditions of interest defined in behavior models. To understand how behavior models work, you must understand the objects that make up behavior models and how they interact.

Behavior Model Objects

NerveCenter uses the objects listed in *Table 2-1* to define behavior models:

TABLE 2-1. NerveCenter Objects Used with Behavior Models

Object	Description
Node	Represents either a workstation, server, or a network device such as a router, hub, or bridge.
Property	A text string that describes the type of node or one of the node's MIB objects. Polls and alarms use properties to target specific nodes.
Property group	A group of properties assigned to a node. The properties in the group allow behavior models to target the node.
Trigger	An internal event that is generated when a defined network event has been detected or a condition satisfied. Triggers are generated by polls and trap masks, as well as by other NerveCenter objects such as Perl subroutines and NerveCenter alarms.
Poll	Periodically solicits defined SNMP values from the agents running on targeted nodes and fires a trigger when specified conditions are met. Polls can fire multiple triggers, which can be detected by one or more alarms.
Trap mask	Detects a predefined type of SNMP trap. Trap masks can specify generic and specific trap numbers, enterprise OIDs, and variable binding data to match against incoming traps. A trap mask fires a trigger when the specified type of trap is detected.
Alarm	Detects triggers that cause the alarm to transition from one state to the next. Each transition is triggered by its own set of network data, which is defined in the poll or mask that generates the associated trigger. The alarm performs any actions assigned to a transition.

Behavior Model Operation

A behavior model is not a NerveCenter object. Rather, it is a collection of NerveCenter objects designed to monitor specific network devices, events, or behaviors. *Figure 2-1* shows the interaction of objects in a simple behavior model.

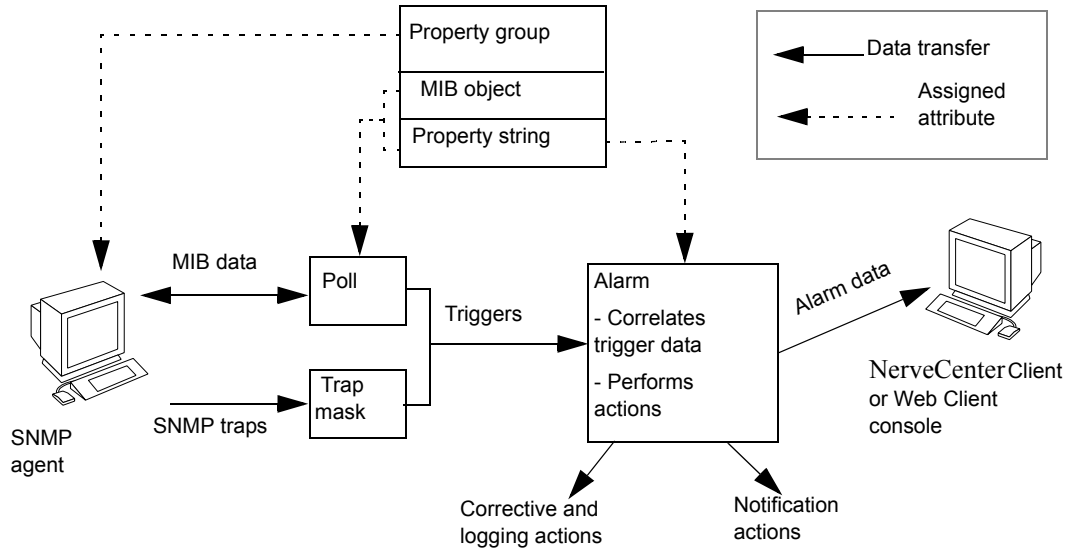

FIGURE 2-1. A Simple Behavior Model

When a trigger-generating object detects an event of interest on a node, it raises a trigger. This trigger generator might be a NerveCenter poll that looks for a specified network condition, or a trap mask that detects a certain type of SNMP trap. NerveCenter alarms internally subscribe for triggers based on alarm states. When an alarm detects its first trigger, the alarm transitions to a predefined state. Based on the state, the alarm ignores triggers that can no longer cause transitions and listens instead for those triggers that can. The alarm waits in that state until another trigger is received—either from the same or another trigger generator. This allows an alarm to react only to relevant events and poll only for relevant data. For more information about alarms, see *Alarms on page 18*.

How Properties Affect Behavior Models

Properties allow you to limit excessive polling and control which nodes are targeted by which alarms. A property is text string that describes the type of node or one of the node's MIB objects. A property group is a group of properties assigned to a node. Each node is targeted based on its assigned property group, which can contain many properties. Before an alarm can be applied to a node, the node's group of properties must include any property specified in the alarm or its associated polls. Additionally, before a node can be polled, the node's property group must contain the MIB base object that the poll is designed to evaluate. Assigning a node to a property group with multiple properties allows the node to be targeted by multiple alarms.

Other Trigger Generators

Alarm transitions can trigger actions that, themselves, generate triggers. Trigger-generating actions can cause a transition in another alarm or transition yet another state in the same alarm. An alarm can also execute a Perl subroutine, which can fire a trigger when certain conditions are met. In both cases, the alarm serves as a trigger generator that serves an important function in a behavior model. These types of trigger generators provide an additional level of control over your alarms.

Figure 2-2 shows the interaction of various trigger generators in a behavior model.

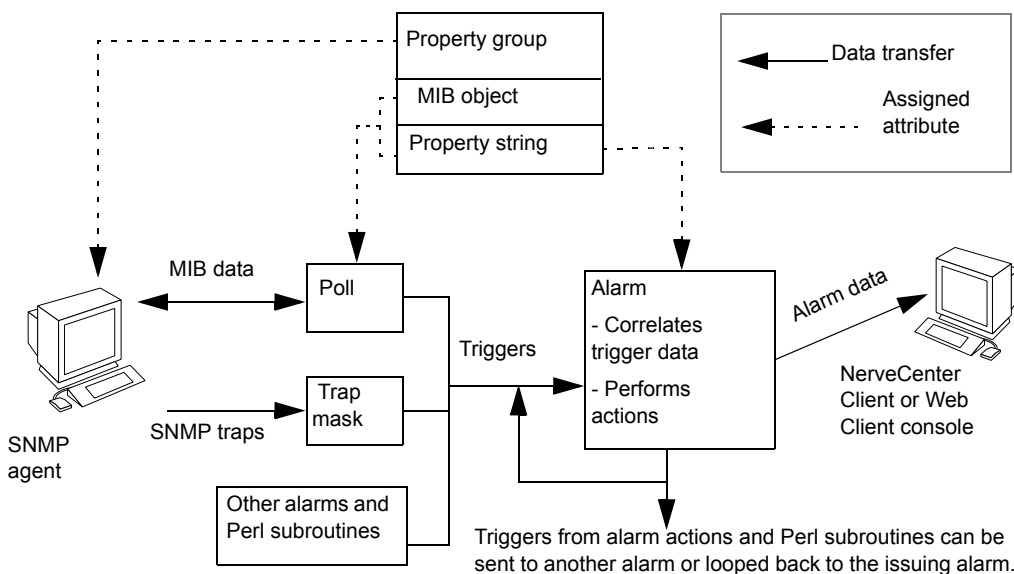

FIGURE 2-2. A Behavior Model with Triggers Generated by Alarms

Alarm Actions

NerveCenter can implement a broad range of actions when an alarm is instantiated. A transition might cause NerveCenter to send a trap, email, or page. NerveCenter has its own type of message—an inform—that contains the variable bindings associated with the event that caused the alarm to transition. Informs can be sent to one or more destinations, including network management platforms and other NerveCenters. For each destination, you can specify a minimum severity level that your network conditions must meet before the informs are issued.

NerveCenter can call a Perl subroutine as an alarm action. The Perl subroutine might fire a trigger when certain conditions are met or execute other commands that effect changes to your network. Perl subroutines have access to associated alarm and trigger data for nodes that cause alarms to transition. Subroutines can then evaluate this information and conditionally take further action.

NerveCenter can also log alarm data and perform corrective actions such as setting SNMP attribute values. Finally, all actions can be performed conditionally using the NerveCenter Action Router. The Action Router performs actions based on user-defined criteria such as time of day, severity of the alarm, type of node, and so on.

Alarms

Alarms are key to behavior model operation. An alarm is a finite state machine that defines the operational states it wants to detect and the transitions from one state to the next when the proper trigger is received. Each transition is triggered by its own set of network data, which is defined in the NerveCenter object that generates the associated trigger. Transitions can also be driven by any alarm action that causes a trigger to be fired. If actions are associated with a transition, the server performs these actions each time the transition takes place.

Figure 2-3 shows the state diagram for an alarm called IfUpDownStatus. IfUpDownStatus monitors the operational status of interfaces on managed nodes. If an interface is down, an inform action notifies the network management platform.

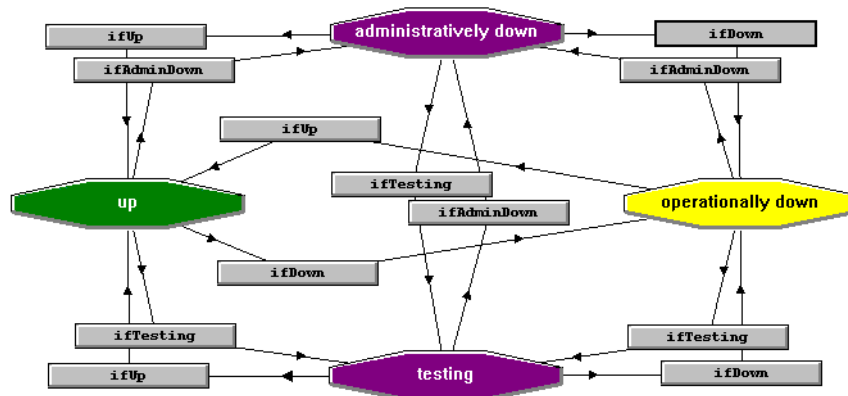

FIGURE 2-3. IfUpDownStatus Alarm

Each state is depicted as an icon in the diagram. The state icons are color coded to represent a particular level of severity.

The alarm contains four states related to the status of an interface:

- ◆ **Up**—The interface is up. The current (operational) and desired (administrative) statuses are set to 1 (defined in RFC1213 as up). This state has a severity level of Normal.
- ◆ **Administratively down**—Both the current (operational) and the desired (administrative) statuses are set to 2, defined in RFC1213 as down.
- ◆ **Testing**—Either the current (operational) or desired (administrative) status is set to 3, defined in RFC1213 as test mode.
- ◆ **Operationally down**—The current (operational) status is down but the desired (administrative) status is up. This state has a high severity level of Major. All transitions leading to this state include an alarm action that sends an inform to NerveCenter or to the platform.

The ifStatus poll fires all the triggers that transition the IfUpDownStatus alarm. The poll is designed to evaluate the MIB base object attributes ifAdminStatus and ifOperStatus, which belong to the ifEntry base object in the interfaces MIB-II group. The poll fires four triggers—one for each of the four states previously described—based on the values returned for the two attributes. The alarm correlates the data it receives from the poll and transitions based on the combinations shown in [Table 2-2](#).

TABLE 2-2. Correlation of IfEntry Attributes in the IfUpDownStatus Alarm

IfUpDownStatus Status	ifAdminStatus	ifOperStatus
Up	1	1
Administratively down	2	2
Testing	3	3
Operationally down	1	2

In this alarm, a trigger representing a condition other than up for either attribute—`ifAdminStatus` or `ifOperStatus`—transitions the alarm from the Up state. A subsequent trigger representing a condition other than up for the remaining attribute then transitions the alarm to a different state. The state to which it transitions depends on the combination of the values for the two attributes.

To learn more about NerveCenter’s behavior models, refer to the following sources:

- ◆ *Learning How to Create Behavior Models* and *Designing and Managing Behavior Models* contain complete descriptions and procedures for behavior models.
- ◆ NerveCenter objects, such as alarms, include notes that describe the object and provide specific information related to that object. For example, the notes for an alarm include a list of triggers that transition the alarm, the objects that fire those triggers, and any actions associated with the alarm’s transitions.

NerveCenter Components

This section introduces the main NerveCenter components:

- ◆ *NerveCenter Server on page 21*
- ◆ *NerveCenter Database on page 21*
- ◆ *NerveCenter MIB on page 22*
- ◆ *NerveCenter Interfaces on page 23*

NerveCenter Server

The NerveCenter Server is responsible for carrying out all of the major tasks that NerveCenter performs. For example, it handles the polling of SNMP agents, creates NerveCenter objects such as the finite alarms mentioned earlier, and makes sure that state transitions occur at the appropriate times. The server also performs all actions associated with state transitions.

The server can run as a daemon on UNIX systems and as a service on Windows systems. This capability to run in the background has important implications with regard to using NerveCenter at remote sites. You can install the server and database at a remote office and have that server manage the local network, yet control the server (via the NerveCenter Client) from a central location. Servers located at remote sites can forward noteworthy information to a server at the central location as required.

NerveCenter Database

The NerveCenter database is primarily a repository for the NerveCenter objects that make up a set of behavior models; the basic objects are introduced in *Behavior Model Objects on page 15*. A set of objects that define many useful behavior models ships with NerveCenter and is available as soon as you've installed the product. On UNIX systems, the NerveCenter database is implemented as a flat file. On Windows systems, the database can be either a Microsoft Access database or a Microsoft SQL Server database.

NerveCenter MIB

NerveCenter enables you to control which types of devices are managed based on their SNMP management information base (MIB) definitions. *Figure 2-4* shows the NerveCenter MIB files along with the other NerveCenter components.

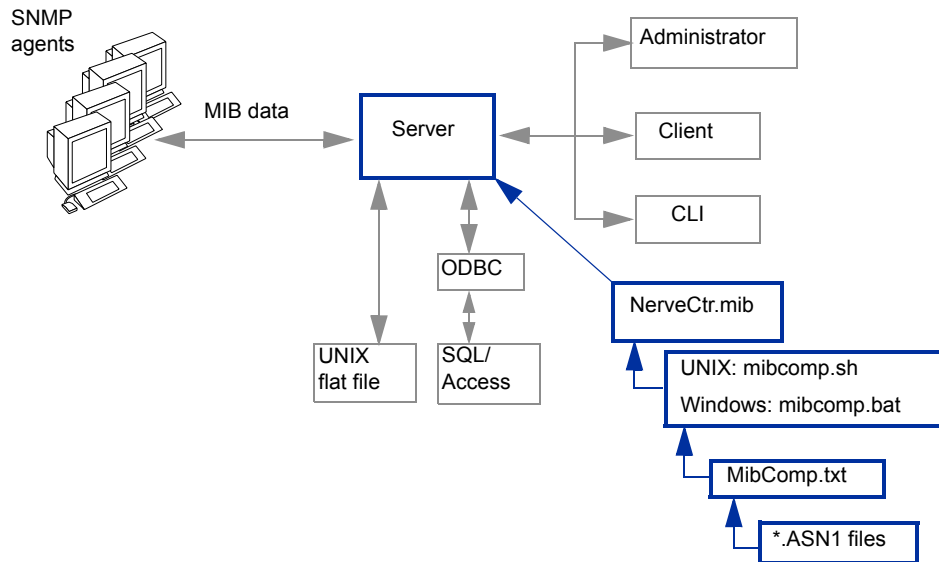

FIGURE 2-4. NerveCenter MIB Files

The compiled MIB file shipped with NerveCenter, `NerveCtr.mib`, contains definitions for Internet Standard RFC SNMP Versions 1, 2 and 3 agents as well as many vendor specific MIBs. `NerveCtr.mib` defines the management information available from an SNMP agent based on the MIBs the agent supports. This support information is contained in the `.ASN1` file for each managed device. NerveCenter's MIB file enables you to construct SNMP requests for particular devices and to decode data received in SNMP traps.

`NerveCtr.mib` is compiled from definitions referenced in a text file, which by default is named `MibComp.txt`. `MibComp.txt`, in turn, points to the `*.ASN1` files you are using. To add support for new devices, modify `MibComp.txt` to include the new `*.ASN1` files, located within the `installation/MIB` directory. You must have the proper `.ASN1` file for each device that is defined.

After modifying the text file, you recompile the MIB file. NerveCenter's MIB compiler, `MibComp`, verifies each respective `.ASN1` file, compiles the definitions in the text file, and creates a new version of `NerveCtr.mib` that can then be loaded into the NerveCenter Server.

NerveCenter Interfaces

This section introduces the four principal user interfaces to the NerveCenter server:

- ◆ *The NerveCenter Administrator on page 24*
- ◆ *The NerveCenter Client on page 26*
- ◆ *The NerveCenter Web Client on page 27*
- ◆ *The Command Line Interface on page 28*

The NerveCenter Administrator

Users with administrator privileges can use the NerveCenter Administrator interface to:

- Configure NerveCenter discovery mechanisms
- Configure the number of SNMP polling retries and the retry interval
- Configure NerveCenter mail and paging actions
- Manage NerveCenter log files
- Configure NerveCenter to work with a network management platform

Figure 2-5 shows the NerveCenter Administrator.

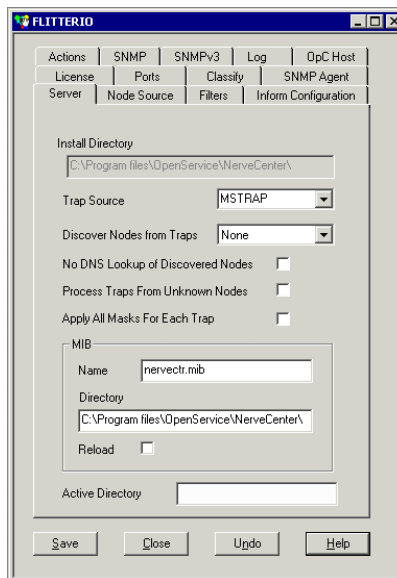

FIGURE 2-5. NerveCenter Administrator

The NerveCenter Client Console

The NerveCenter Client lets you monitor the network as well as create and modify the behavior models managed by the NerveCenter Server. You can access the MIBs, nodes, behavior models, alarm filters, and other NerveCenter objects associated with that Server. The Alarm Summary window displays all current alarms for the connected Server.

Figure 2-6 shows a sample Alarm Summary window.

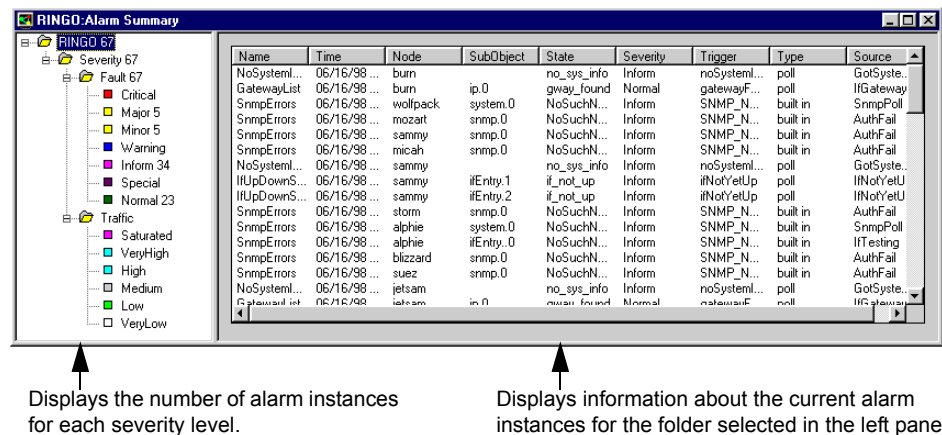

FIGURE 2-6. Alarm Summary Window

The left pane contains a tree that displays the total number of current alarm instances, the number of instances in each severity group (Fault and Traffic), and the number of instances of each severity. If there is no number next to a severity, there are no active alarm instances of that severity.

The right pane provides detailed information about current alarm instances for the folder or severity that is highlighted in the tree view.

The NerveCenter Client

Figure 2-7 shows the GUI for the NerveCenter Client.

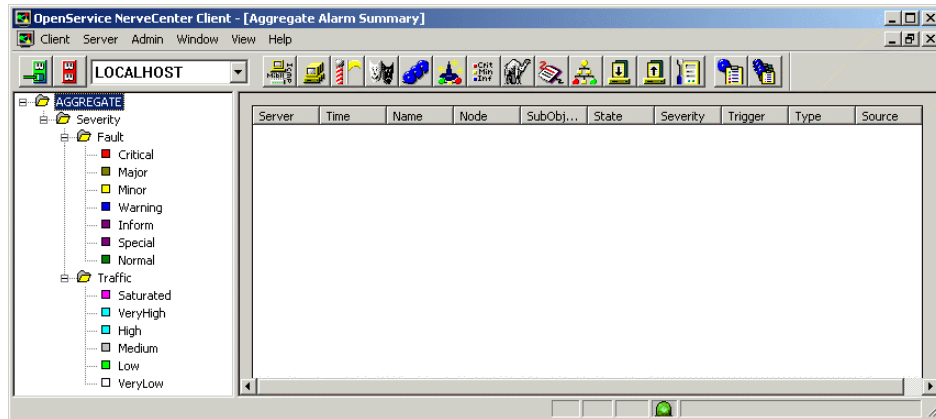

FIGURE 2-7. NerveCenter Client

Two types of users run the NerveCenter Client. Users with NerveCenter User privileges can run the client to:

- ◆ Monitor active alarms
- ◆ Filter alarms for the alarm summary windows
- ◆ View an alarm's history
- ◆ Reset alarms
- ◆ Monitor the state of managed nodes
- ◆ Generate reports

For complete information on using the NerveCenter Client to perform the tasks listed above and others, see *Monitoring Your Network*.

Users with NerveCenter Administrator privileges can perform all the tasks that users with User privileges can. In addition, they can use the client to:

- ◆ Create new behavior models
- ◆ Customize the predefined behavior models
- ◆ Modify, copy, or delete any object in the NerveCenter database

The NerveCenter Web Client

NerveCenter provides a Web-based console, called the NerveCenter Web Client, that lets you monitor network activity from any machine that has a Microsoft Internet Explorer or Netscape Navigator browser installed. In order to use a Web-based console, you must install NerveCenter's Web support component, the Web Collector. The Web Collector can be installed on the NerveCenter Server host or on your Web server.

Figure 2-8 shows how the Web Collector works with NerveCenter components.

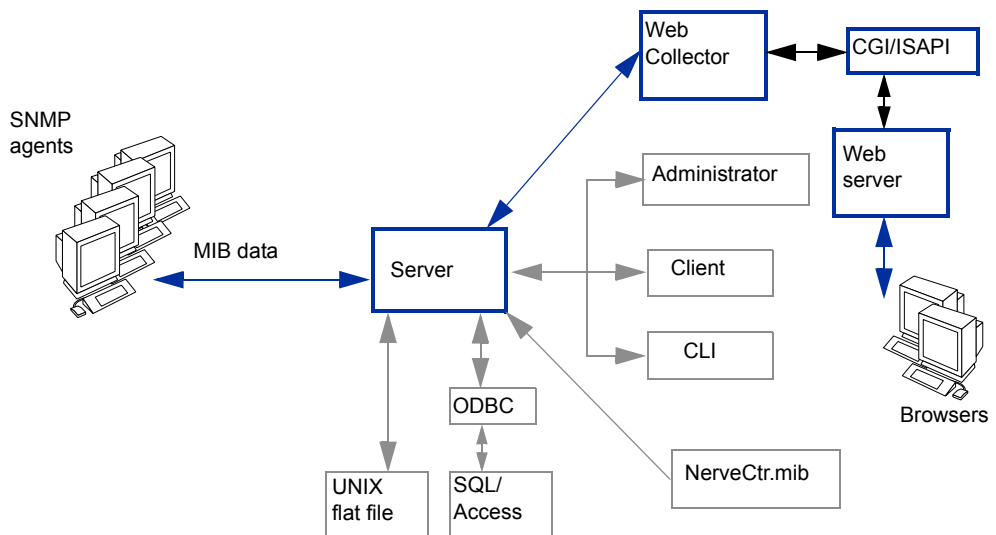

FIGURE 2-8. Web Server Integration

You can monitor NerveCenter alarms from a browser by entering `http://webserver/NerveCenter`, where *webserver* is the name of the machine on which your Web server is running. After entering this URL, your Web server invokes a NerveCenter CGI/ISAPI application that connects you to the Web Collector. The Web Collector is responsible for transmitting information between the NerveCenter Server and the Web Client browser. Through the Web Collector, the NerveCenter Server prompts you to enter your NerveCenter user name and password. The NerveCenter Server verifies your logon and, in turn, provides alarm data. This alarm information is relayed through the Web Collector, CGI application, and Web server to your browser.

Figure 2-9 shows the GUI for the NerveCenter Web Client.

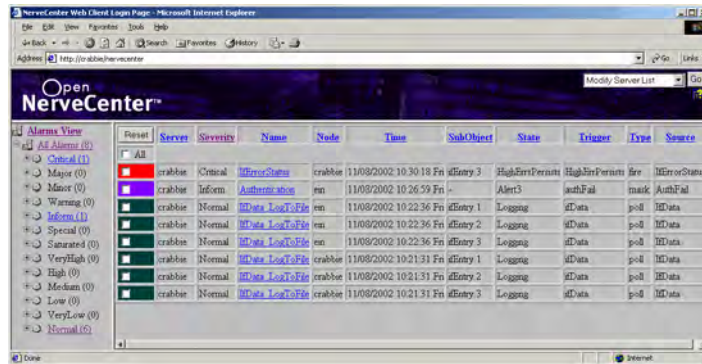

FIGURE 2-9. NerveCenter Web Client

The NerveCenter Web Client, unlike the NerveCenter Client, is meant to be used only for monitoring a network, not for creating behavior models. It enables you to:

- Monitor active alarms
- View an alarm's history
- Reset alarms
- Monitor the state of managed nodes

For complete information on using the web client, see *Monitoring Your Network*.

The Command Line Interface

You can use NerveCenter's command line interface (CLI) to delete, list, or set (enable or disable) alarms, trap masks, nodes, and polls from a Windows Command Prompt or a UNIX shell. You can also connect to, display the status of, and disconnect from NerveCenter servers using the CLI. You can issue commands manually or from a script.

See *Appendix C, Controlling NerveCenter from the Command Line* for command descriptions.

Role in Network Management Strategy

NerveCenter can play a variety of roles in an overall network management strategy. The role that NerveCenter plays in your strategy depends largely on the size of your network and on what other products you are using to manage your network and systems:

- ◆ If you are managing a small network, NerveCenter can be used as a standalone system. It can discover the workstations and network devices on the network, detect and correlate network conditions, respond automatically to conditions, and display information about active alarms. See the section *Standalone Operation on page 30* for further information.
- ◆ For larger networks, multiple NerveCenters can be used in concert. Local NerveCenter systems could be set up to manage remote sites, and the local NerveCenter servers could forward important information to the NerveCenter server at the central site. See the section *Using Multiple NerveCenter Servers on page 31* for further information.
- ◆ NerveCenter can be used in conjunction with a network management platform such as Hewlett Packard OpenView Network Node Manager, Hewlett Packard OpenView IT/Operations, CA Unicenter TNG, IBM Tivoli TME, and IBM Tivoli Netcool/OMNIbus which manages systems, networks, intranets, and databases. NerveCenter can be configured to receive messages from or send messages to these network management platforms. See the section *Integration with Network Management Platforms on page 32* for further information.

Standalone Operation

At smaller sites, you can use NerveCenter alone for your network management tasks. As we've seen, NerveCenter is very strong in the areas of event correlation and automated actions. In addition, NerveCenter includes an alarm console, as shown in [Figure 2-10](#).

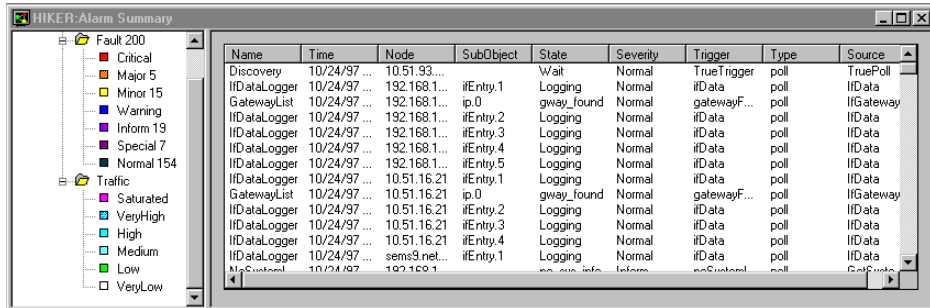

FIGURE 2-10. NerveCenter's Alarm Console

This console displays information about every current alarm instance. In addition, if you double-click on a line in the event console, you are taken to an Alarm History window that displays information about all of the alarm transitions that have occurred for the alarm instance you selected.

At small installations, no discovery mechanism is necessary; you can add nodes to NerveCenter manually. At somewhat larger sites, however, such a mechanism is helpful, and NerveCenter provides one in its Discovery behavior model.

Using Multiple NerveCenter Servers

Because a NerveCenter server can inform another NerveCenter server or management platform of a network condition, it's possible to set up NerveCenter servers at remote sites that notify a centrally located NerveCenter server or management platform (*Figure 2-11*).

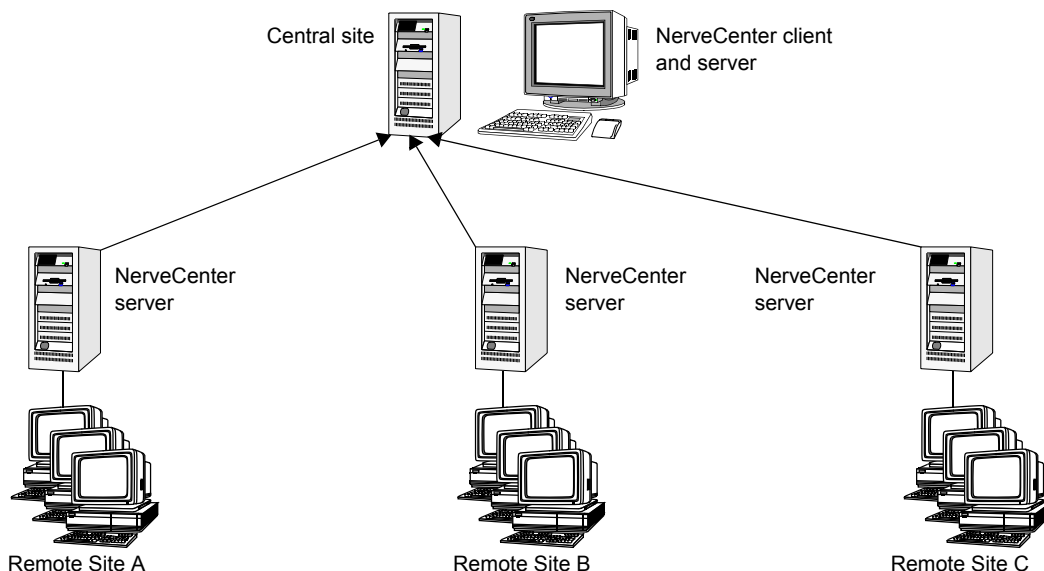

FIGURE 2-11. Distributed NerveCenter Servers

This is a reliable solution because the remote NerveCenter servers use TCP/IP to notify the central NerveCenter server and retransmit messages as necessary to ensure their delivery. There are a few advantages to this type of setup:

- ◆ Only a small amount of data is transmitted over the WAN. Any bandwidth intensive monitoring is conducted on a LAN and is managed by a remote NerveCenter server.
- ◆ Remote NerveCenter servers can be run in lights-out mode, which means that:
 - ◆ NerveCenter runs as a Windows service or as a UNIX daemon
 - ◆ You can monitor and configure NerveCenter from a remote location
 - ◆ You can modify all NerveCenter parameters without shutting NerveCenter down
 - ◆ No display or operators are required at a site
- ◆ The central NerveCenter can further correlate and filter conditions across remote NerveCenter Server domains

Integration with Network Management Platforms

A network management platform (NMP) is an operations and problem-management solution for use in a distributed multi-vendor environment. Intelligent distributed agents on managed nodes monitor system and application log files and SNMP data. The agents apply filters and thresholds to monitored data and forward messages about conditions of interest to a central management station. When the management station receives messages, it can automatically take corrective action—such as broadcasting a command to a set of systems—or an operator can initiate a response.

Additionally, with OpenView Network Node Manager, you can direct NerveCenter to take its node information from the management platform and configure NerveCenter to take over all polling activity and event processing.

You can integrate your NerveCenter installation with the NMP so that the NMP can send messages to NerveCenter for correlation or processing. After the messages arrive, NerveCenter correlates the conditions described in these messages with related conditions—from the NMP or from other sources—and can respond with any of its alarm actions, as appropriate. In addition, NerveCenter can send a message to an NMP in response to any network condition, whether the condition was originally detected by the NMP or not.

NMPs alone can detect a condition and invoke an action in response. However, you must integrate the NMP with NerveCenter if you want to:

- ◆ Correlate conditions detected by the NMP on different devices
- ◆ Correlate different types of conditions detected by the NMP on the same device
- ◆ Correlate conditions detected by the NMP with other types of events or conditions on the same device or across different devices

See *Integrating NerveCenter with a Network Management Platform* for more information.

NerveCenter is designed to run in the background, quietly monitoring your network. Fortunately, it does not require a great deal of administrative attention. There are, however, some initial settings as well as ongoing maintenance issues that must be attended to. A person designated as a NerveCenter administrator usually handles these tasks.

This chapter includes the following sections:

Section	Description
<i>Who Uses NerveCenter? on page 34</i>	Explains the difference between basic users, power users, and administrators of NerveCenter.
<i>NerveCenter Login Rights on page 35</i>	Explains the difference between login rights as a user and as an administrator.
<i>The Role of a NerveCenter Administrator on page 36</i>	Recommends habits a NerveCenter administrator should develop.

Who Uses NerveCenter?

Although not necessary, you may find it helpful to think of three different groups who use NerveCenter:

- ◆ NerveCenter **basic users** – monitor NerveCenter using either NerveCenter Client or the Web Client. They have user login rights and should read *Monitoring Your Network*.
- ◆ NerveCenter **power users** – design and manage behavior models using the NerveCenter Client. They have administrator login rights and should read *Designing and Managing Behavior Models* and *Learning How to Create Behavior Models*.
- ◆ NerveCenter **administrators** – manage the administrative tasks related to NerveCenter. They have administrator login rights and use the NerveCenter Administrator tool. A NerveCenter administrator should read this book.

Table 3-1 illustrates the differences between the three.

TABLE 3-1. The Differences between Three Groups of NerveCenter Users

	Primary Task	Primary Tool	Rights*	Book
Basic user	Monitoring NerveCenter	NerveCenter Client; Web Client	User	<i>Monitoring Your Network</i>
Power user	Designing and managing behavior models	NerveCenter Client	Administrator	<i>Designing and Managing Behavior Models</i> <i>Learning How to Create Behavior Models</i>
Administrator	Administering NerveCenter	NerveCenter Administrator	Administrator	<i>Managing NerveCenter</i>

NerveCenter Login Rights

By default, during installation NerveCenter establishes two groups with different login rights:

- ◆ NerveCenter users
- ◆ NerveCenter administrators

Only those with NerveCenter administrators login rights can start the NerveCenter Administrator application.

Those with either NerveCenter administrators and users login rights can start the NerveCenter Client application. However, opening under NerveCenter Users login rights limits what you can do with the Client.

Table 3-2 illustrates the difference between NerveCenter administrators and NerveCenter users login rights.

TABLE 3-2. User and Administrator Login Rights in NerveCenter Client

	User	Administrator
Monitor active alarms	✓	✓
View an alarm's history	✓	✓
Reset alarms	✓	✓
Monitor the state of managed nodes	✓	✓
Generate reports	✓	✓
Create new behavior models		✓
Customize the predefined behavior models		✓
Add login rights to another NerveCenter user		✓
Modify, copy, or delete an object in the NerveCenter database		✓

The Role of a NerveCenter Administrator

Because NerveCenter is intended to run in the background, quietly monitoring your network, it does not require a great deal of administrative maintenance. There are, however, a few regular habits a NerveCenter administrator should develop. These include:

- ◆ Backing up the NerveCenter database. See *Backing up the Database on page 213*.
- ◆ Checking to see that there is available disk space for each log file.
- ◆ Checking log files to make sure they are truncating to the correct size. See *Specifying Settings for Log Management on page 194*.
- ◆ Checking for logged errors or messages in the event viewer for Windows or the system log files for UNIX. These errors or messages could indicate problems that could be currently affecting NerveCenter performance or could later develop into a problem.
- ◆ Checking all your NerveCenter Server's Server Status pages to make sure all necessary connections are available. See *Viewing NerveCenter Server Status on page 48*. You will want to monitor information on the following tabs:
 - ◆ Node Source: Is the connection with the node data source still available?
 - ◆ Inform Configuration: Is the inform recipient list current?
 - ◆ Connected NerveCenter: Does this list show all the NerveCenter Servers that may potentially send the active server an inform packet?
 - ◆ OpC Host: Is the connection to the machine hosting OpenView IT/Operations still available?
- ◆ Updating any relevant changes in IP addresses, such as the location of a node data source or inform recipients.
- ◆ Keeping various NerveCenter login rights current to reflect changes in personnel. See *Managing NerveCenter Security on page 171*.
- ◆ Keeping the NerveCenter serial numbers up to date. See *Working with NerveCenter Serial Numbers on page 62*.
- ◆ Maintaining your network management platform with good procedures. For example, in Network Node Manager running `ovtopofix -a` weekly to reconcile the Network Node Manager databases.
- ◆ Monitor the OpenService Software Technical Support Web for news ideas and procedures at www.openservice.com.

Running the NerveCenter Server

Before a client can connect to a NerveCenter Server, the Server must be installed and running. See *Installing NerveCenter* for instructions on installing the NerveCenter Server and other applications. This chapter explains how to start and stop the NerveCenter Server.

This chapter includes the following sections:

Section	Description
<i>Running the NerveCenter Server on UNIX on page 38</i>	Explains how to start and stop the NerveCenter Server on a UNIX platform.
<i>Running the NerveCenter Server on Windows on page 39</i>	Explains how to start and stop the NerveCenter Server on a Windows platform.
<i>Troubleshooting: Running the NerveCenter Server on page 40</i>	Lists common problems users face when running the NerveCenter Server.

Running the NerveCenter Server on UNIX

If NerveCenter is not running as a UNIX daemon, you can start it manually.

TO START NERVECENTER SERVER MANUALLY ON UNIX

1. Before you can run any NerveCenter application on UNIX, you must set the necessary environments by executing one of the following shell scripts:
 - ◆ `install_path/userfiles/ncenv.sh`
 - ◆ `install_path/userfiles/ncenv.csh`
 - ◆ `install_path/userfiles/ncenv.ksh`

where `install_path` is typically `/opt/OSInc`.



TIP

An administrator should add the lines from these files to the login scripts of all users who are going to be using NerveCenter on UNIX.

2. From the `install_path/bin` directory, where `install_path` is typically `/opt/OSInc`, type the following command:

```
install_path/bin/ncstart
```



NOTE

If you want to disable all alarms when you start the server (for example, if you create an alarm that crashes the server) type **ncstart -off**.

For other command line switches, see [Controlling NerveCenter from the Command Line on page 289](#).

Running the NerveCenter Server on Windows

During a NerveCenter installation, the NerveCenter Server is installed as a Windows service. During installation, the choice is given to have the NerveCenter Server service start up automatically. If the NerveCenter Server is installed as a service but not as an automatic service, you must start it manually each time.

TO START THE NERVECENTER SERVER AS A SERVICE

Use any of the following methods:

- ◆ Choose **Start > Programs > OpenService NerveCenter > NerveCenter Service**.
- ◆ Select the NerveCenter Service from Service applet in the Windows Control Panel and choose **Start**.
- ◆ From the command line, type:

```
ncstart -s
```

TO STOP RUNNING THE NERVECENTER SERVER AS A SERVICE

Use either of the following methods:

- ◆ Select the NerveCenter Service from the Windows Services applet in the Windows Control Panel and chose **Stop**.
- ◆ From the command line, type:

```
ncstop -s
```

to stop the NerveCenter Service

or

```
ncstop -All
```

to stop all running NerveCenter applications.

Troubleshooting: Running the NerveCenter Server

This section contains some common problems users may have when running the NerveCenter Server.

UNIX will not start the NerveCenter Server

Problem: The environment variables are not set.

Solution: Execute one of the following shell scripts:

- ◆ *install_path*/userfiles/ncenv.sh
- ◆ *install_path*/userfiles/ncenv.csh
- ◆ *install_path*/userfiles/ncenv.ksh

where *install_path* is typically /opt/OSInc.

An alarm causes the NerveCenter Server to crash every time I start it

Problem: Any alarm that is enabled when a NerveCenter Server stops is still enabled when the NerveCenter Server starts again.

Solution: Start the NerveCenter Server with all its alarms turned off by typing at the command prompt `ncserver -off &`.

The NerveCenter Server does not start on Windows

Problem: The NerveCenter Server was installed as a manual service.

Solution: Start the NerveCenter Service manually by typing at the command prompt `ncstart -s`.

I need to get a better idea of what the NerveCenter Server is doing on Windows. Can I temporarily run it as a process?

Problem: NerveCenter typically runs as a Windows service, which causes a number of its functions to be hidden to users.

Solution: You can start NerveCenter Server as a Windows process by typing at the command line `ncstart -p`.

Connecting to a NerveCenter Server

For you to administer one or more NerveCenter Servers, you will need to make a connection between the NerveCenter Server and a NerveCenter Administrator application.

This chapter includes the following sections:

Section	Description
<i>Starting NerveCenter Administrator on page 42</i>	Explains how to start the NerveCenter Administrator application.
<i>Connecting Administrator to a NerveCenter Server on page 44</i>	Explains how to connect a NerveCenter Administrator to a NerveCenter Server.
<i>Connecting Administrator to Multiple NerveCenter Servers on page 46</i>	Explains the issues involved in connecting a single NerveCenter Administrator to more than one NerveCenter Server.
<i>Deleting a Name from the Administrator's Server List on page 47</i>	Explains how to delete a misspelled or old server name from the Administrator's server list.
<i>Viewing NerveCenter Server Status on page 48</i>	Explains how to view the Server Status window to view basic information concerning the active NerveCenter Server.
<i>Disconnecting the Administrator from a NerveCenter Server on page 50</i>	Explains how to disconnect the NerveCenter Administrator from a NerveCenter Server without closing the Administrator window.
<i>Troubleshooting: Connecting to the NerveCenter Server on page 51</i>	Lists common problems users face when starting the NerveCenter Administrator and connecting to a NerveCenter Server.

Starting NerveCenter Administrator

The NerveCenter Administrator provides an administrator information about one or more active NerveCenter Servers. An administrator also uses the application to configure settings on a NerveCenter Server.

Starting the NerveCenter Administrator differs depending on the operating system:

- ◆ [Starting the NerveCenter Administrator on UNIX on page 42](#)
- ◆ [Starting the NerveCenter Administrator on Windows on page 43](#)

Starting the NerveCenter Administrator on UNIX

TO START THE NERVECENTER ADMINISTRATOR ON UNIX

1. Open a terminal window.
2. Type the following command:

```
ncadmin &
```

If you receive an error message, it is possible the necessary environment variables have not been set. See [Running the NerveCenter Server on UNIX on page 38](#).

A NerveCenter Administrator window opens.

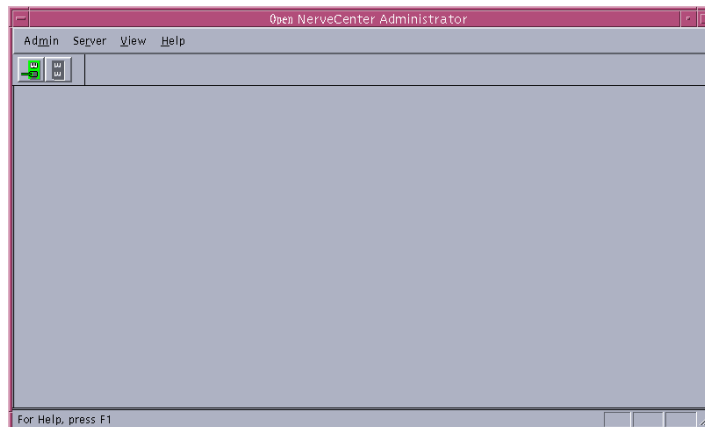

Starting the NerveCenter Administrator on Windows

TO START THE NERVECENTER ADMINISTRATOR ON WINDOWS

1. Select **Start**.

**NOTE**

The following is the default path suggested during NerveCenter installation. It could be different.

2. Select **Programs**, then **OpenService NerveCenter**.
3. Select **Administrator**.

A NerveCenter Administrator window opens.

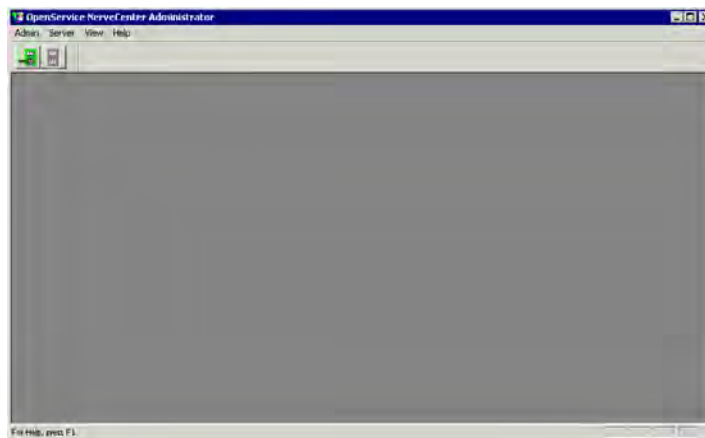
**TIP**

It is also possible to start the NerveCenter Administrator from a command prompt, by typing **ncadmin**.

Connecting Administrator to a NerveCenter Server

Before you can use the NerveCenter Administrator, you must connect to a NerveCenter Server. The NerveCenter Server provides the functionality required to manage your network. Also, it gives the NerveCenter Administrator access to the settings found in the NerveCenter database.

You can connect your NerveCenter Administrator to more than one server at one time. However, only one NerveCenter Server can be the *active server* at a time. The active server determines which NerveCenter database is used when you are configuring settings.

To connect NerveCenter Administrator to a server, you must be an administrator or a member of a NerveCenter group on the server:

- ♦ If using Windows, you must be a member of the NerveCenter Admins group or be logged in as an administrator.
- ♦ If using UNIX, you must be a member of the nadmins group or be logged in as root.

TO CONNECT A NERVECENTER ADMINISTRATOR TO A NerveCenter SERVER



1. Open NerveCenter Administrator. See [Starting NerveCenter Administrator on page 42](#).
2. From the **Server** menu, select **Connect Server**.

The Connect to Server window is displayed.

A screenshot of a Windows-style dialog box titled "Connect to Server". It has a blue title bar with a question mark and close button. The dialog contains three input fields: "Server Name" (a dropdown menu), "User ID" (a text box), and "Password" (a text box). At the bottom, there are three buttons: "Connect", "Cancel", and "Help".

3. Do one of the following:
 - a. If this is the first time connecting to the NerveCenter Server, type in the Server Name field the hostname or IP address of the machine on which the NerveCenter Server is running.
 - b. If you have connected to the server before, select the name or IP address from the Server Name list.

The first time you connect to a server, the list is empty. After that, it contains a list of the machines to which you've connected, or attempted to connect, in the past. The list will not display the names of machines to which this NerveCenter Administrator is already connected. (For information on removing an entry from the Server Name list, see the section *Deleting a Name from the Administrator's Server List on page 47.*)

4. Type a user name and password in the **User ID** and **Password** fields.

You must enter a user name and password. The user whose name you enter here must be a member of the NerveCenter Users or NerveCenter Admins group (Windows) or the ncusers or ncadmins group (UNIX).

5. Select **Connect**.

If the machine to which you try to connect is not running a NerveCenter Server, you will see the message: **The server did not respond**. You must first start the NerveCenter Server and then try to connect again. See *Running the NerveCenter Server on page 37* for more details.

When the NerveCenter Administrator connects to a NerveCenter Server, the Administrator window for that server appears.

Connecting Administrator to Multiple NerveCenter Servers

It is possible to use a NerveCenter Administrator to connect to more than one NerveCenter Server at the same time. However, only one NerveCenter Server can be the active server at a time. The active server determines which NerveCenter database is used when you are configuring settings.

To connect a NerveCenter Administrator to more than one NerveCenter Server, follow the steps in the section [Connecting Administrator to a NerveCenter Server on page 44](#) for each NerveCenter Server. NerveCenter Administrator will display a window for each connected NerveCenter Server. You will probably need to move the windows to view each Server separately.

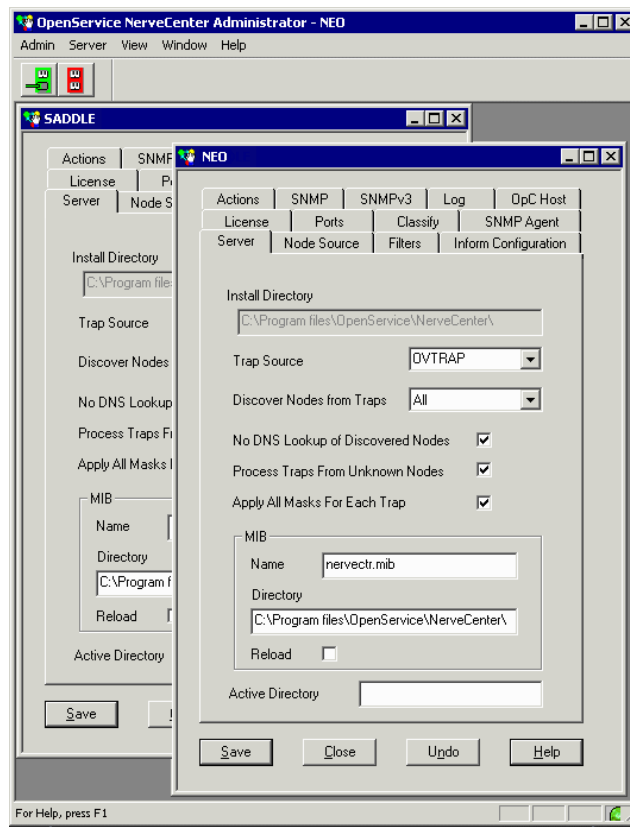

FIGURE 5-1. NerveCenter Administrator Connected to More Than One NerveCenter Server
The name of the active server always appears in the title bar of the main NerveCenter Administrator window.

Deleting a Name from the Administrator's Server List

NerveCenter maintains a list of servers that the NerveCenter Administrator has attempted to connect to in the past. This list is used in the Connect to Server window, which you use to connect the administrator to a server.

As helpful as this list is, there may be times when you need to delete a server from this list. It may be the name of a server that you will never connect to again. It could also be the misspelled name of a server you were unable to connect to because of the misspelling.

TO DELETE A SERVER FROM THE ADMINISTRATOR'S SERVER NAME LIST

1. Open NerveCenter Administrator. See [Starting NerveCenter Administrator on page 42](#).
2. From the **Admin** menu, select **Configuration**.

The NCAAdmin Configuration window is displayed.

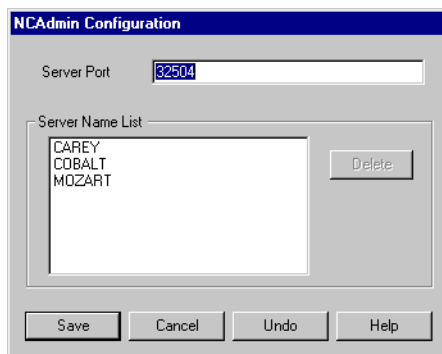

The Server Name List contains the names of all the machines this NerveCenter Administrator has attempted to connect to in the past.

3. In the Server Name List, highlight the machine name that you wish to delete.
4. Select **Delete**.

The machine name is removed from the Server Name List.

5. Select **Save**.

The server's name is permanently deleted from the Server Name List for this NerveCenter Administrator.

Viewing NerveCenter Server Status

The Server Status window of NerveCenter Administrator and Client allow you to see current information pertaining to an active NerveCenter Server.

TO VIEW INFORMATION ABOUT A NERVECENTER SERVER

1. Open NerveCenter Administrator and connect to a NerveCenter Server See [Connecting Administrator to a NerveCenter Server on page 44](#).
2. From the **Server** menu, select **Server Status**.

NerveCenter displays the Server Status window for the active NerveCenter Server.

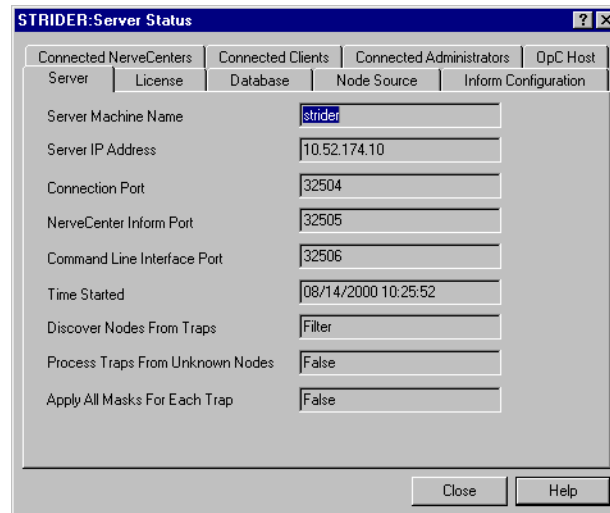

3. To close the window, select **Close**.
-

The Server Status window has several tabs that display read-only data about the active NerveCenter Server. [Table 5-1](#) describes the Server Status Tabs.

TABLE 5-1. Server Status Tabs

Tab	Description
Server	Displays information about the connected NerveCenter Server, such as its ports and basic settings.
License	Displays information about the serial numbers associated with the active NerveCenter Server.
Database	Displays information about the database this NerveCenter Server is using. Includes statistics on its current behavior models.
Node Source	Displays the node filters as well as node source, if applicable, this NerveCenter Server is using to maintain its node list.
Inform Configuration	Displays the settings involved in forwarding event information to one or more inform recipients.
Connected NerveCenters	Displays information about each NerveCenter Server that may potentially send an inform packet to the active NerveCenter Server.
Connected Clients	Displays information about each host running a NerveCenter Client connected to the active NerveCenter Server.
Connected Administrators	Displays information about each host running a NerveCenter Administrator connected to the active NerveCenter Server.
OpC Host	Displays information, if applicable, about the NerveCenter's HP OpenView IT/Operations host.

Disconnecting the Administrator from a NerveCenter Server

When you no longer need to configure settings in NerveCenter Administrator, you can disconnect from a NerveCenter Server. If you are connected

When you close a NerveCenter Administrator, all connections to NerveCenter servers are broken. However, you may also want to disconnect the administrator from a server without stopping a NerveCenter Administrator.

TO DISCONNECT A NERVECENTER ADMINISTRATOR FROM A SERVER



1. In NerveCenter Administrator, select the window of the server from which you want to disconnect.
2. From the **Server** menu, choose **Disconnect Server**.

A warning message appears asking if you are sure you want to disconnect from the active server.

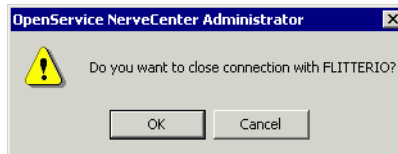

3. Select **OK**.

NerveCenter Administrator remains open but is no longer connected to the NerveCenter Server.

Troubleshooting: Connecting to the NerveCenter Server

The following list contains some common problems users have when starting NerveCenter Administrator and connecting to the NerveCenter Server.

UNIX will not start the NerveCenter Administrator

Problem: The environment variables are not set.

Solution: Execute one of the following shell scripts:

- ◆ /opt/OSInc/userfiles/ncenv.sh
- ◆ /opt/OSInc/userfiles/ncenv.csh
- ◆ /opt/OSInc/userfiles/ncenv.ksh

See *Running the NerveCenter Server on UNIX on page 38*.

While trying to connect to a NerveCenter Server I get the message: The server did not respond

Problem: The NerveCenter Server is not currently running.

Solution: Start the NerveCenter Server and then connect.

See *Running the NerveCenter Server on UNIX on page 38* or *Running the NerveCenter Server on Windows on page 39*.

I misspelled a server name while trying to connect and now the misspelled name appears in the NerveCenter Administrator Server Name list

Problem: NerveCenter Administrator remembers the name of every server you attempted to connect to.

Solution: Remove the misspelled name by deleting it from the Administrator's configuration window.

See *Deleting a Name from the Administrator's Server List on page 47*.

NerveCenter is based on a client/server architecture. This means the user views information and interacts with NerveCenter through client applications while most of NerveCenter's actions are carried out by the NerveCenter Server.

Much of the information NerveCenter needs to detect and correlate events are provided when behavior models are created. However, a NerveCenter administrator must configure and maintain certain foundational settings.



NOTE

To change the default port settings used by NerveCenter for various communications, see [Managing NerveCenter Port Settings on page 79](#).

This chapter includes the following sections:

Section	Description
Managing the NerveCenter Trap Source on page 54	Explains how to determine and change the trap source, or trap engine, you want to use for capturing SNMP traps.
Working with NerveCenter Serial Numbers on page 62	Explains the purpose of NerveCenter serial numbers and how to add and delete them.
Reconfiguring a NerveCenter Server from the Command Line on page 66	Explains how to change settings to a NerveCenter Server by importing an .ini file.
Troubleshooting: Managing the NerveCenter Server on page 78	Lists common problems users face when managing the NerveCenter Server.

Managing the NerveCenter Trap Source

During installation, you indicated which trap source, or trap engine, you wanted to use for capturing SNMP traps. You can later change this trap source. Keep in mind that neither MSTRap nor OVTrapD support SNMP v3.

See the following sections for more information:

- ◆ [Trap Source Overview on page 54](#)
- ◆ [Changing the SNMP Trap Source on page 56](#)

Trap Source Overview

During installation, you indicated whether NerveCenter should be configured to support SNMP v3. Depending on your answer, your platform, and whether OpenView Network Node Manager is coresident on your system, your trap source is one of the following:

TABLE 6-1. NerveCenter SNMP v3 Trap Sources

Platform	OpenView Coresident	OpenView Not Coresident
Windows	NerveCenter or OVTrapD	NerveCenter MSTRap
UNIX	NerveCenter or OVTrapD	NerveCenter

When NerveCenter is your trap source, NerveCenter uses the port specified on the Ports tab for capturing traps. This value, SNMP Trap port, is 162 by default. If you want NerveCenter to capture traps, this port must be free for NerveCenter to capture the traps.

During installation, if you selected NerveCenter as your SNMP Trap Source, you were asked to disable MSTRap or OVTrapD service on your system so that the trap port (162) would be free for NerveCenter to use.

After installation, you can change the trap source in NerveCenter Administrator. Keep in mind that neither MSTRap nor OVTrapD support SNMP v3.

Following are the types of traps supported by the trap engines:

- ◆ OVTrapD: SNMP v1 and v2C traps
- ◆ MS Trap Service: SNMP v1 and v2C traps
- ◆ NerveCenter: SNMP v1, v2C, and v3 traps

To manage SNMP v3 traps, you must use NerveCenter as a trap source.

NerveCenter Trap Utilities

NerveCenter includes the following trap-related utilities:

- ◆ **Trapgen** — Generates a trap or inform on a specified node.
- ◆ **Traprcv** — Receives traps and shows the traps in standard output.

The following sections briefly describe each utility; see [Appendix C, Controlling NerveCenter from the Command Line](#) for more information.

Trapgen

TrapGen is a standalone utility that allows you to send an SNMP trap or inform to a particular device. From a command line or shell prompt, you can set the generic and specific trap numbers, provide the sender and recipient IP addresses, include an enterprise identifier, and specify the variable bindings.

Generating a trap is useful for testing trap masks and behavior models. When you send an SNMP trap to a NerveCenter Server, any trap mask configured to detect the specified trap values fires its trigger. If your trap mask and alarm are working properly, you see the alarm listed in your console.

Traprcv

The traprcv command displays the SNMP Trap messages received by the NerveCenter Trap service. This utility can be useful when debugging behavior models. When you run the traprcv command from a command line or shell prompt, any trap you receive is shown on the screen.

Traprcv can receive the following traps and informs:

- ◆ SNMPv1 Traps
- ◆ SNMPv2c Traps
- ◆ SNMPv2c Informs
- ◆ SNMPv3 Traps
- ◆ SNMPv3 Informs

Changing the SNMP Trap Source

When NerveCenter is your trap source, NerveCenter uses the port specified on the Ports tab for capturing traps. This value, SNMP Trap port, is 162 by default. If you want NerveCenter to capture traps, this port must be free for NerveCenter to capture the traps. This may require that you shut down MS Trap service and/or OVTrapD.

Follow the steps below to change the trap source used to process traps. The sequence is important because the current trap source has to release the port before the new trap source can use that port.

TO CHANGE THE NERVECENTER TRAP SOURCE

1. Open NerveCenter Administrator and connect to the appropriate Server.

See [Connecting Administrator to a NerveCenter Server on page 44](#).

2. Select the **Server** tab.

The Server page is displayed.

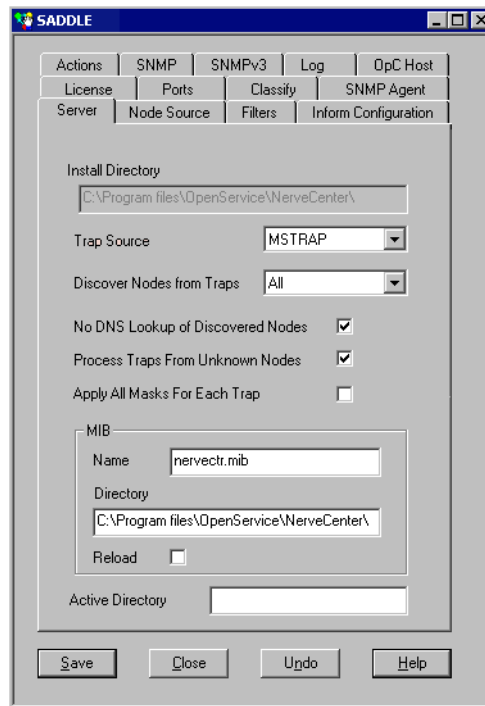

3. Select the trap engine you want to use from the Trap Source drop-down listbox.
4. Select **Save**.
5. Shut down the NerveCenter Server.
6. If applicable, stop the old trap service and then start the new one.
Refer to [Table 6-2](#) for details.
7. Restart the NerveCenter Server.

[Table 6-2](#) summarizes what to do when changing the trap source.

TABLE 6-2. Changing the Trap Source

Switching From	Switching To	Action To Take...
OVTrapD or MS Trap	NerveCenter	Shut down OVTrapD and MS Trap service. If both are on your system, shut down both. Disable the MS Trap Service. If SNMP Trap port is other than 162 in NerveCenter, you don't need to shut down OVTrapd or MStrap service.
NerveCenter	OVTrapD	Start OVTrapD.
NerveCenter	MS Trap	Start MS Trap service. Disable the NerveCenter SNMP Trap service.
OVTrapD	MS Trap	Stop OVTrapD. Start MS Trap service.
MS Trap	OVTrapD	Stop MS Trap service. Start OVTrapD.

TO CHANGE FROM THE NERVECENTER TRAP SERVICE TO MSTRAP

1. Select **MSTRAP** as your trap source.
 - a. Open NerveCenter Administrator and connect to the appropriate Server.
 - b. Select the **Server** tab.

The Server tab displays.
 - c. Select **MSTRAP** from the Trap Source drop-down listbox.
 - d. Select **Save**.

A dialog box displays stating Data saved successfully.
 2. Disconnect from the Server and shut down NerveCenter Administrator.
 3. Stop the following services in the order given:
 - a. NerveCenter service
 - b. NerveCenter SNMP service
 4. Set Startup type of the SNMP Trap Service to Automatic.

Follow the instructions of [To disable the MS Trap service on page 62](#) but select **Automatic** instead of **Disabled**.
 5. Start the following service in the order given:
 - a. SNMP Trap Service service
 - b. NerveCenter SNMP service
 - c. NerveCenter service
-

If you have snmputil installed, you can test that MS Trap service is receiving traps.

TO TEST WHETHER THE MS TRAP SERVICE IS RECEIVING TRAPS

1. Run snmputil trap at a command prompt.

The utility returns snmputil: listening for traps...

2. Enter the following command:

```
trapgen -v1 your_ip-address 1.3.6.1.4.78 your_ip-address 6 101 132
```

snmputil should return the following text:

```
Incoming Trap:
generic      = 6
specific    = 101
enterprise   = .iso.org.dod.internet.private.enterprises.78
agent       = your ip-address
source IP   = your ip-address
community   = public
```

If the AllTraps_LogToFile alarm is enabled, the alltraps.log should contain the following lines.

```
Time=10/22/2002 13:11:02 Tue; LogId=1; DestStateSev=Normal;
NodePropertyGroup=NC
DefaultGroup; NodeName=mycomputer;
AlarmName=AllTraps_LogToFile;
OrigState=Ground;
TriggerName=allTraps; DestState=Logging; TrapPduTime=132;
TrapPduGenericNumber=6
; TrapPduEnterprise=1.3.6.1.4.1.78;
TrapPduSpecificNumber=101;
TriggerInstance=;
TriggerBaseObject=
```

TO CHANGE FROM THE MSTRAP SERVICE TO NERVECENTER TRAP SERVICE

1. Select NerveCenter as your trap source.
 - a. Open NerveCenter Administrator and connect to the appropriate Server.
For instructions, see [Connecting to a NerveCenter Server on page 41](#).
 - b. Select the **Server** tab.
The Server tab displays.
 - c. Select NerveCenter from the Trap Source drop-down listbox.
 - d. Select **Save**.
A dialog box displays stating **Data saved successfully**.
 2. Disconnect from the Server and shut down NerveCenter Administrator.
For instructions, see [Disconnecting the Administrator from a NerveCenter Server on page 50](#).
 3. Stop the following services in the order given:
 - a. NerveCenter service
 - b. NerveCenter SNMP service
 - c. SNMP Trap Service service
 4. Set Startup type of the SNMP Trap Service to Disabled.
Follow the instructions of [To disable the MS Trap service on page 62](#).
 5. Start the following services in the order given:
 - a. NerveCenter SNMP service
 - b. NerveCenter service
-

You can test that the NerveCenter Trap service is running.

TO TEST WHETHER THE NERVECENTER TRAP SERVICE IS RECEIVING TRAPS

1. Run `traprcv` in a command window.

The utility returns `Waiting for traps`.

2. Enter the following command:

```
trapgen -v1 your_ip-address 1.3.6.1.4.78 your_ip-address 6 101 132
```

`traprcv` should return the following text:

```
Received SNMPv1 Trap:
Community: public
From: your ip-address:2057
Enterprise: enterprises.7
Agent-addr: your ip-address
Enterprise Specific trap: 101
Time Ticks: 132
```

If the `AllTraps_LogToFile` alarm is enabled, the `alltraps.log` should contain the following lines.

```
Time=10/22/2002 13:38:02 Tue; LogId=1; DestStateSev=Normal;
NodePropertyGroup=NC
DefaultGroup; nodeName=mycomputer;
AlarmName=AllTraps_LogToFile;
OrigState=Ground;
TriggerName=allTraps; DestState=Logging; TrapPduTime=132;
TrapPduGenericNumber=6
; TrapPduEnterprise=1.3.6.1.4.1.78;
TrapPduSpecificNumber=101;
TriggerInstance=;
TriggerBaseObject=
```

TO DISABLE THE MS TRAP SERVICE

1. Open the Services control panel by selecting the following from the **Start** menu:
Settings > Control Panel > Administrative Tools > Services
 2. Right-click on the **SNMP Trap Service** and select **Properties** from the menu.
 3. From the Startup Type listbox, select **Disabled**.
 4. Select **OK**.
-

Working with NerveCenter Serial Numbers

Every NerveCenter Server needs at least one serial number. Each serial number indicates:

- ◆ The number of NerveCenter Clients that are permitted to connect to that NerveCenter Server
- ◆ The number of nodes that the NerveCenter Server can monitor

You can purchase new serial numbers from your authorized sales reseller or representative to increase the number of NerveCenter Clients that can connect to a NerveCenter Server and/or the number of nodes that can be monitored by a NerveCenter Server.

The sequencing of the serial number keys is not guaranteed. There is no way to tell which single serial number is active at any instant. The total number of nodes and Clients that can connect to the Server are a cumulative figure of all the serial numbers that have been accepted.

When managing NerveCenter serial numbers, administrators perform two actions:

- ◆ *Adding a Serial Number to a NerveCenter Server on page 63*
- ◆ *Deleting an Old Serial Number from a NerveCenter Server on page 64*

To learn about the rules NerveCenter follows and restrictions imposed when adding and deleting serial numbers, see *NerveCenter Rules for Managing Serial Numbers on page 65*.

Adding a Serial Number to a NerveCenter Server

Once you obtain a new serial number from your authorized sales representative, you will need to add the serial number to the appropriate NerveCenter Server.



NOTE

You can also add a NerveCenter serial number using the ImportUtil tool. See [Reconfiguring a NerveCenter Server from the Command Line on page 66](#).

TO ADD A NEW SERIAL NUMBER TO A NERVECENTER SERVER

1. Open NerveCenter Administrator and connect to the appropriate Server. See [Connecting Administrator to a NerveCenter Server on page 44](#).
2. Select the **License** tab.

The License tab is displayed.

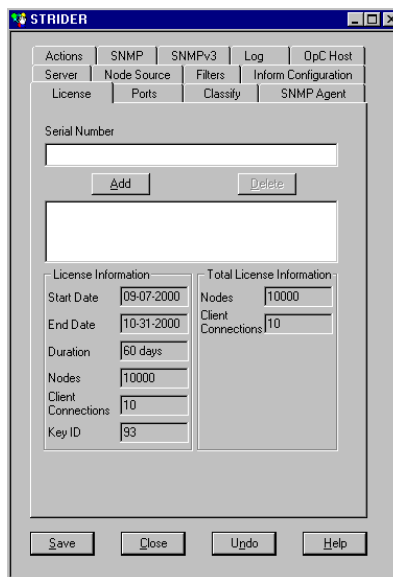

The license tab of administrator allows you to view information about current serial numbers, delete old serial numbers, and add new serial numbers.

3. In the Serial Number field, type the new serial number.
4. Select **Add**.

Licensing information associated with this serial number is displayed at the bottom of the License tab.

5. If you have more than one serial number, repeat steps 3 and 4.
 6. Select **Save**.
-

The NerveCenter Server monitors as many nodes and establishes a connection with as many NerveCenter Clients as the serial number permits.

Deleting an Old Serial Number from a NerveCenter Server

As a NerveCenter serial number expires, you can remove it from the NerveCenter Server's data.



NOTE

NerveCenter will not allow you to delete your last serial number. If you want to replace an evaluation serial number with a permanent one, add the permanent number first and then you can delete the evaluation number.

TO DELETE AN OLD SERIAL NUMBER FROM A NerveCenter SERVER

1. Open NerveCenter Administrator and connect to the appropriate Server. See [Connecting Administrator to a NerveCenter Server on page 44](#).
 2. Select the **License** tab.
The License tab is displayed.
 3. From the list of serial numbers, highlight the serial number you want to remove.
 4. Select **Delete**.
The serial number is removed from the serial number list.
 5. Select **Save**.
-

The serial number is removed from the NerveCenter Server.

NerveCenter Rules for Managing Serial Numbers

NerveCenter tracks how many serial numbers are registered for a particular NerveCenter Server and what types of serial numbers they are (permanent or evaluation). NerveCenter follows certain rules to manage serial numbers. For example, when removing serial numbers, NerveCenter will not allow you to delete your last serial number.

The following table summarizes the rules that NerveCenter follows to manage serial numbers.

TABLE 6-3. NerveCenter Rules for Serial Numbers

If you currently have...	NerveCenter does the following...
No serial number	<ul style="list-style-type: none"> ◆ Accepts either an evaluation or permanent serial number. ◆ Does not manage a network until you have added at least one valid evaluation or permanent serial number.
Evaluation serial number	<ul style="list-style-type: none"> ◆ Accepts a permanent serial number to replace the evaluation number. Add the permanent number first and then you can delete the evaluation number. ◆ Does not accept any additional evaluation serial numbers. ◆ Does not allow you to delete the last serial number. ◆ Does not accept duplicate entries for the same serial number.
Expired evaluation serial number	<ul style="list-style-type: none"> ◆ Automatically removes the expired number from the list and reduces accordingly the total number nodes and clients that are managed. ◆ Accepts either a valid evaluation or permanent serial number.
One or more permanent serial numbers	<ul style="list-style-type: none"> ◆ Accepts any number of additional permanent serial numbers. ◆ Accepts a single valid evaluation serial number; a second evaluation serial number will not be accepted. ◆ Allows you to delete any of the serial numbers except the last one. ◆ Does not accept duplicate entries for the same serial number.

Reconfiguring a NerveCenter Server from the Command Line

An alternative to using the NerveCenter Administrator to configure a NerveCenter Server is to use the utility ImportUtil. ImportUtil is a utility that does the following from the command line:

- ◆ Imports behavior models and nodes to a NerveCenter Server.
- ◆ Imports configuration settings to a NerveCenter Server.

Using this utility allows you to reconfigure a setting on more than one NerveCenter Server at a time by changing one file and importing it to all the relevant servers. *Figure 6-1* shows ImportUtil along with the other NerveCenter components.

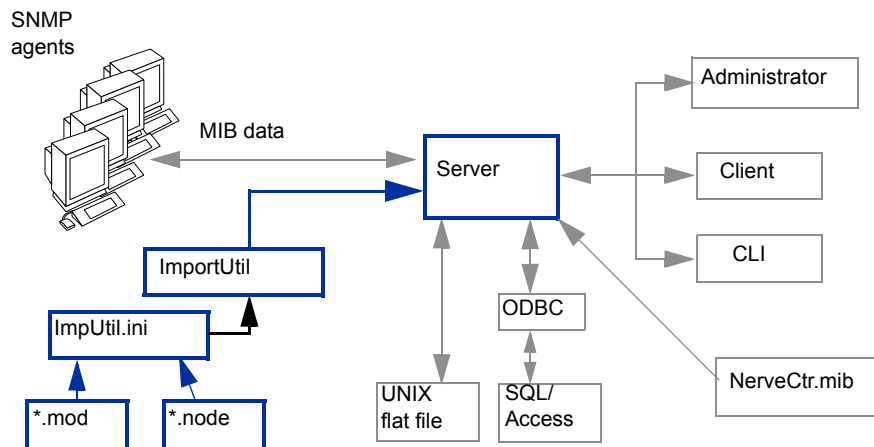

FIGURE 6-1. NerveCenter ImportUtil Utility

ImportUtil imports the data referenced in the editable file `ImpUtil.ini`, which is located in the *installation/Sms* directory (Windows) or the *installation/userfiles* directory (UNIX).

You can edit NerveCenter configuration settings in `ImpUtil.ini` as well as specify the behavior models and nodes you want to import. You must have the proper `*.mod` or `*.node` file for the behavior models or nodes you want to import. When you have made the changes you want to `ImpUtil.ini`, run `ImportUtil` to import the specified information or files.

See *Appendix C, Controlling NerveCenter from the Command Line* for more information.

TO RECONFIGURE A NERVECENTER SERVER FROM THE COMMAND LINE

1. Find the file `imputil.ini`.
 - ♦ In a typical NerveCenter installation on Windows, this file can be found in the folder `Sms`, in the NerveCenter folder.
 - ♦ In a typical NerveCenter installation on UNIX, this file can be found in the directory `install_path/userfiles`, where `install_path` is typically `/opt/OSInc`.

The file `imputil.ini` is made of a number of sections that include a section header and keys.

2. Before making any changes, create a backup copy of the file `imputil.ini`.

**CAUTION**

If you do not edit `imputil.ini` correctly, you can misconfigure or corrupt your NerveCenter Server. You may want to test your changes to `imputil.ini` in a test environment before running `importutil` in a production environment.

You will not be able to restore the original `imputil.ini` after making changes to the file, unless you first make a backup copy.

3. Delete all but the relevant sections to be changed.

[Table 6-4 on page 69](#) describes all sections in `imputil.ini`. All sections in the file are optional. If you remove a section, including the section header and keys, `ImportUtil` does not change or delete any values in the NerveCenter configuration settings for that key.

For example, if you are changing a value found only in the section `[CONFIG_SERVER]`, you delete all sections except the section header and the values in the `[CONFIG_SERVER]` section. `ImportUtil` will only change the values pertaining to that section.

4. Within the remaining sections, delete everything but the section headers and the relevant keys.

Any new values left in `imputil.ini` will overwrite the old values. To avoid having placeholders overwrite legitimate values, delete any unnecessary keys before running `ImportUtil`.

For example, if within the `[CONFIG_SERVER]` section you only want to change the value of the key `InformNCListenPort`, delete all but the following:

```
[CONFIG_SERVER]
InformNCListenPort = port
```

**CAUTION**

If you are configuring the [CONFIG_PLATFORM_NETNODENOTIFY] or [CONFIG_PLATFORM_MAPSUBNETS] sections, you must include all values, including old values. ImportUtil deletes values from the NerveCenter configuration settings that are not included in these sections. Please read the comments before each section in this file for more information.

5. Change the values by replacing the placeholders after the equal sign (=) with valid values.

Unless otherwise noted, you may not leave the value after a key blank.

For example, if you want to change the value of the key InformNCListenPort to 6024, change the file to read:

```
[CONFIG_SERVER]
InformNCListenPort = 6024
```

Table 6-4 describes all imputil.ini sections.

6. Save the changed file.
7. While the NerveCenter Server is running, run the utility ImportUtil from a UNIX shell or a Windows command prompt by typing:

```
importutil imputil.ini
```

**CAUTION**

You must either be in the same directory as the imputil.ini file or include the full pathname of the imputil.ini file.

NerveCenter notifies you upon successful completion of the reconfiguration.

TABLE 6-4. imputil.ini Value Descriptions

imputil.ini value pair	Description
[CONFIG_PLATFORM]	
This section configures integrations with network management platforms.	
To remove a value, leave the value after the equal sign (=) blank. For example: MapHost=	
<p>Note: Except for OpCHost, the cross-references in this section refer to integrating with HP OpenView. You may need to review the chapter in <i>Integrating NerveCenter with a Network Management Platform</i> appropriate for your network management platform.</p>	
MapHost = host/port/resyncparentrate	These are the hostname, port, and resync Parent rate defined on the Node source tab. For more details about this value, see <i>Identifying Parent-Child Relationships in Integrating NerveCenter with a Network Management Platform</i>
OpCHost = host/port	The hostname and port number of the IT/Operations machine. For more details about this value, see <i>Specifying the Destination of NerveCenter Inform Packets sent to HP OpenView IT/Operations in Integrating NerveCenter with a Network Management Platform</i> .
Method = Auto Manual	When the method is set to Automatic, NerveCenter ignores your address filters. It looks at the IP address and mask for each network interface card on that server and uses them to calculate the subnet address and mask. Enter Manual if you want NerveCenter to use your address filters as entered. For details see <i>Filtering Nodes by IP Address on page 105</i>
WantedCapabilities = cap1,cap2,...	<p>You can monitor nodes with particular capabilities, which your network management system typically assigns to a node to determine the applicable activities such as isRouter, isHub, and isIP.</p> <p>Filtering by capabilities is available only when your network management platform has assigned specific capabilities to a node.</p> <p>For more details about this value, see <i>Filtering Using a Node's Capabilities on page 103</i>.</p>
SystemObjectIds = id1,id2,...	NerveCenter allows you to monitor managed nodes according to their particular system object identifiers (OIDs). For more details about this value, see <i>Filtering Using a Node's System Object Identifier on page 104</i> .

TABLE 6-4. imputil.ini Value Descriptions (Continued)

imputil.ini value pair	Description
MaxQueueDepth = maximum queue depth	The number of Informs NerveCenter keeps if connection with the network management platform goes down. For more details about this value, see <i>How to Configure the Inform Queue Depth in Integrating NerveCenter with a Network Management Platform</i> .
AckInforms = 0/1	If you want NerveCenter to keep track of informs until the platform adapter acknowledges their receipt, you must enable the inform acknowledgement feature by setting AckInforms = 1. For more details about this value, see <i>How to Save NerveCenter Informs until Acknowledgement in Integrating NerveCenter with a Network Management Platform</i> .
NoFiltersOnImport = 0/1	If you have a node list you want to import of known hosts you want to monitor, you may not want to apply the IP and Hostname filters. Enter 0 for false and 1 for true. For more details about this value, see <i>Enabling and Disabling IP and Hostname Filters on page 111</i> .
HostnameFilters = hostname1 *hostname2 . . .	Besides IP addresses, you can also filter by hostnames. For more details about this value, see <i>Filtering Nodes by Hostnames on page 110</i> .
[CONFIG_PLATFORM_MAPSUBNETS]	
This section configures the IP filtering for node lists imported from a network management platform. If the method in [CONFIG_PLATFORM] is AUTO, the entries in this section are ignored.	
Caution: You must include all values from this section, including old values. ImportUtil deletes values from the NerveCenter configuration settings that are not included in these sections.	
Note: If you want to apply filters to a list of nodes you are importing, first run importutil to change the filters. Then run importutil again to import the nodes.	
MapSubNet1 = Address;Mask;Exclusion list	You can filter nodes by subnet. For more details about this value, see <i>Filtering Nodes by IP Address on page 105</i> .
MapSubNet2 = Address;Mask;Exclusion list	

TABLE 6-4. imputil.ini Value Descriptions (Continued)

imputil.ini value pair	Description
[CONFIG_PLATFORM_NETNODENOTIFY]	
This section configures what information NerveCenter sends to the Network Management Platform.	
<p>Caution: You must include all values from this section, including old values. ImportUtil deletes values from the NerveCenter configuration settings that are not included in these sections.</p>	
<p>Note: The cross-references in this section refer to integrating with HP OpenView. You may need to review the chapter in <i>Integrating NerveCenter with a Network Management Platform</i> appropriate for your network management platform.</p>	
host/port/type = EVENT_ONLY EVENT_AND_SYMBOL SYMBOL_ONLY [Min Severity] [Properties]	<p>The type of information sent to the network management platform. For more details about these values, see <i>Sending NerveCenter Informs to HP OpenView Network Node Manager in Integrating NerveCenter with a Network Management Platform</i>.</p> <p>Note: Type must be either OVPA or PA_SVR</p>
[CONFIG_SERVER]	
This section configures the NerveCenter Server.	
ServerConnPort = port	<p>The NerveCenter Server communicates with other applications, such as NerveCenter Client and NerveCenter Administrator, on a special connection port. For more details about this value, see <i>Configuring the NerveCenter Server Connection Port on page 80</i>.</p> <p>If you change a NerveCenter Server's communication port number, be sure all applications, such as NerveCenter Administrator, have a matching port number. See <i>Changing the NerveCenter Administrator's Server Port on page 82</i> for more details.</p>
CLICConnPort = port	<p>The port number you want the NerveCenter Server to use for client/server communication. For more details about this value, see <i>Changing the NerveCenter Client's Server Port on page 83</i>.</p>

TABLE 6-4. imputil.ini Value Descriptions (Continued)

imputil.ini value pair	Description
InformNCListenPort = port	Before a NerveCenter Server can receive an Inform, it must be configured to have a listening port number. For more details about this value, see <i>Configuring NerveCenter to Receive Inform Actions on page 84</i> .
LicenseKey = key	The license key or serial number for NerveCenter. For more details about this value, see <i>Working with NerveCenter Serial Numbers on page 62</i> .
NCMibName = MibName	The filename of the mib file you want to import into NerveCenter. You enter the path in [CONFIG_SERVER_PATH]. For more details about this value, see <i>Configuring NerveCenter to Use the New MIB on page 237</i> .
EnableDiscovery = TRUE FALSE	If true, NerveCenter adds nodes discovered by traps to the database. For more details about this value, see <i>Adding Nodes Discovered from Traps on page 125</i> .
DiscoverNodesFromTraps = All Filter None	For more details about this value, see <i>Populating Using the IPSweep Behavior Model on page 119</i> .

TABLE 6-4. imputil.ini Value Descriptions (Continued)

imputil.ini value pair	Description
OVTrapperPath = MSTRAP OVTRAPD NCNOMSTRAP NCNOOVTRAP ALWAYS NCNEVER NCALWAYS	<p>Windows:</p> <ul style="list-style-type: none"> ◆ MSTRAP - traps are received from Microsoft SNMP Trap Service. ◆ OVTRAPD - traps are received via ovtrapper from HP OpenView. ◆ NCNOMSTRAP - traps are received via the NerveCenter SNMP Trap agent. Use if NerveCenter is <i>not</i> co-resident with HP OpenView. ◆ NCNOOVTRAP - traps are received via the NerveCenter SNMP Trap agent. Use if NerveCenter is co-resident with HP OpenView. <p>UNIX:</p> <ul style="list-style-type: none"> ◆ ALWAYS - traps are received via ovtrapper from HP OpenView ◆ NCNEVER - traps are received via the NerveCenter SNMP Trap agent. Use if NerveCenter is <i>not</i> co-resident with HP OpenView. ◆ NCALWAYS - traps are received via the NerveCenter SNMP Trap agent. Use if NerveCenter is co-resident with HP OpenView. <p>For more details about this value, see <i>The OpenView Platform Adapter in Integrating NerveCenter with a Network Management Platform</i>.</p>
useOvTrapd = MSTRAP OVTRAP	The NerveCenter trap source. For more details about this value, see <i>Managing the NerveCenter Trap Source on page 54</i> .

TABLE 6-4. imputil.ini Value Descriptions (Continued)

imputil.ini value pair	Description
ApplyAllMasksForEachTrap = TRUE FALSE	<p>Set to TRUE if you want NerveCenter to process every incoming SNMP trap against all defined trap masks that are currently enabled. Selecting this option forces masks to process traps regardless of the state of their associated alarms. A mask processes traps even when its associated alarm is turned off or is not in a state that can be transitioned by the mask's trigger.</p> <p>There are times, however, when masks do not process traps though this option may be checked. A mask processes traps only when the following conditions are met:</p> <ul style="list-style-type: none"> ◆ The mask is turned on. ◆ The incoming trap matches the generic, specific, or enterprise OID values defined in the mask.
[CONFIG_SERVER_PATH]	
Path information.	
MibDirectory = Location of Mib	The path to the mib file you want to import into NerveCenter. You enter the filename in [CONFIG_SERVER]. For more details about this value, see <i>Configuring NerveCenter to Use the New MIB on page 237</i> .
LogDirectory = Location of logs	The location of any log created by a Behavior Model or other component of NerveCenter. For details about this value, see <i>Specifying Settings for Log Management on page 194</i> .
[CONFIG_SERVER_PAGER]	
This section configures the paging properties.	
TouchPulse =	Enter the frequency. Default is 1200. For details about this value, see <i>Setting Dialing Properties for Paging Notification on Windows on page 190</i> .
DialOutNumber =	The number required to reach an outside line, for example, 9. For details about this value, see <i>Setting Dialing Properties for Paging Notification on Windows on page 190</i> .
PauseString =	The characters used to create a pause between dialing and sending data. For details about this value, see <i>Setting Dialing Properties for Paging Notification on Windows on page 190</i> .
[CONFIG_SERVER_SNMP]	
This section configures SNMP settings.	

TABLE 6-4. imputil.ini Value Descriptions (Continued)

imputil.ini value pair	Description
SnmpRetry = No. of retries	The number of times to reissue unanswered SNMP or ICMP request polls. For more details about this value, see <i>Specifying SNMP Poll Intervals for NerveCenter on page 147</i> .
SnmpInterval = No. of Intervals	The number of seconds NerveCenter should wait for a reply to a poll before issuing another. For more details about this value, see <i>Specifying SNMP Poll Intervals for NerveCenter on page 147</i> .
DefaultPort = port no.	The port number NerveCenter uses for SNMP traps. For more details about this value, see <i>Specifying SNMP Ports for NerveCenter on page 88</i> .
[CONFIG_SERVER_SNMPV3]	
This section configures the SNMP v3 settings.	
PollUser = poll user	The SNMP v3 user name. For more details about this value, see <i>Changing the NerveCenter SNMP v3 User Name and Context on page 157</i> .
PollContext = poll context	The SNMP v3 context. For more details about this value, see <i>Changing the NerveCenter SNMP v3 User Name and Context on page 157</i> .
AutoClassify = on off	Whether NerveCenter attempts to classify the SNMP format of discovered nodes. For more details about this value, see <i>Classifying Nodes Automatically on page 143</i> .
AuthPwd = unencrypted (plain text) authentication password (min 8 chars and max 32 chars)	The Authentication password for an SNMP v3 node. For more details about this value, see <i>Changing the SNMP v3 Key Passwords on page 155</i> .
PrivPwd = unencrypted (plain text) privacy password (min 8 chars and max 32 chars)	The Privacy password for an SNMP v3 node. For more details about this value, see <i>Changing the SNMP v3 Key Passwords on page 155</i> .
MaxClassifyVer = v1 v2c v3	If autclassification is enabled, you can limit to what level NerveCenter attempts to classify nodes. For more details about this value, see <i>Setting a Maximum Classify Value on page 145</i> .

TABLE 6-4. imputil.ini Value Descriptions (Continued)

imputil.ini value pair	Description
MaxReqPerCycle = Max no. of requests going out of v3opmanager per second	You control SNMP v3 performance by setting a maximum number of requests per processing cycle (approximately one second) for all v3 operations including classification, SNMP test version poll, version change, authentication protocol change, security level change, and initialization requests. For more details about this value, see <i>Setting the Maximum SNMP v3 Requests per Cycle on page 146</i> .
updateKeys = T F	To update the passwords on all managed agents, enter T. For more details about this value, see <i>Changing the SNMP v3 Key Passwords on page 155</i> .
[CONFIG_SERVER_LOGS]	
This section configures the NerveCenter Logs.	
MaxLogEntryAge =	The number of hours you want to keep individual log entries before they are deleted from the rest of the log. For more details about this value, see <i>Specifying Settings for Log Management on page 194</i> .
MaxLogFileSize =	The size limit, in kilobytes, of the ASCII text file storing the results of the Log to File alarm action. For more details about this value, see <i>Specifying Settings for Log Management on page 194</i> .
MaxNumDBRecords =	The highest number of records in the database file storing the results of the Log to Database alarm action. For more details about this value, see <i>Specifying Settings for Log Management on page 194</i> .
LogDelPercentage =	The percentage of the log to clear when the maximum file size or the maximum number of records is reached. For more details about this value, see <i>Specifying Settings for Log Management on page 194</i> .
MaxQueueDepth =	The highest number of changes that you want queued before saving to the database. For more details about this value, see <i>Specifying Settings for Log Management on page 194</i> .
[CONFIG_SERVER_MSMAIL]	
This section configures Microsoft Mail.	

TABLE 6-4. imputil.ini Value Descriptions (Continued)

imputil.ini value pair	Description
Profile =	The NerveCenter-designated Exchange profile to point to the machine hosting the Microsoft Exchange Server and the NerveCenter-designated mailbox created in <i>Configuring NerveCenter to Send Microsoft Mail on page 184</i> .
Password =	The password to the NerveCenter-designated mailbox created in <i>Configuring NerveCenter to Send Microsoft Mail on page 184</i> .
[CONFIG_SERVER_SMTPMAIL]	
This section configures SMTP mail.	
SMTPHost =	The name of the host running your SMTP mail server. For more details about this value, see <i>Specifying an SMTP Server for Mail Notification on page 182</i> .
[IMPORT_MODEL]	
Use this section to import a NerveCenter Behavior Model.	
File = model_path_and_filename	For more details about this value, see <i>Importing Node, Object, and Behavior Model Files in Designing and Managing Behavior Models</i> .
[IMPORT_NODE]	
Use this section to import a NerveCenter Node List.	
File = node_path_and_filename	For more details about this value, see <i>Importing Node, Object, and Behavior Model Files in Designing and Managing Behavior Models</i> .

Troubleshooting: Managing the NerveCenter Server

The following list contains some common problems users may have when managing the NerveCenter Server.

When I try to connect to a NerveCenter Server it tells me: Number of allowed client connection exceeded

Problem: The NerveCenter Server's license has expired or is inadequate for your needs.

Solution: Contact your authorized NerveCenter reseller or representative to obtain a new serial number.

See *Working with NerveCenter Serial Numbers on page 62*.

I need to make the same changes to several NerveCenter Servers

Problem: It would be time consuming to configure each NerveCenter Server manually from the NerveCenter Administrator.

Solution: Create one `imputil.ini` file and import it to all the NerveCenter Servers.

See *Reconfiguring a NerveCenter Server from the Command Line on page 66*.

Importing `imputil.ini` caused unwanted changes to a NerveCenter Server

Problem: `ImportUtil` imports all values found in `imputil.ini`, including the defaults.

Solution: When using `ImportUtil`, delete all but the relevant keys.

See *Reconfiguring a NerveCenter Server from the Command Line on page 66*.

NerveCenter is based on a client/server architecture. This means that while the NerveCenter Server does the work, you make changes to the server using a client application, such as NerveCenter Client and NerveCenter Administrator. For these applications and a NerveCenter Server to communicate, they must use the same port connection. The Port tab enables you to specify various ports used by the NerveCenter Server.

This chapter includes the following sections:

Section	Description
<i>NerveCenter's Client/Server Communication Port on page 80</i>	Explains how to change the port at which NerveCenter Server communicates with its client applications.
<i>Configuring NerveCenter to Receive Inform Actions on page 84</i>	Explains how to configure a NerveCenter Server to receive an inform action from another NerveCenter Server.
<i>Changing the Command Line Interface Port on page 86</i>	Explains how to change the port NerveCenter uses for its command line interface.
<i>Specifying SNMP Ports for NerveCenter on page 88</i>	Describes how to configure the ports NerveCenter uses to receive SNMP traps and send/receive SNMP correspondences.
<i>Troubleshooting: Managing NerveCenter Port Connections on page 90</i>	Provides troubleshooting tips related to ports.

NerveCenter's Client/Server Communication Port

NerveCenter is based on a client/server architecture. This means that while the NerveCenter Server does the work, you make changes to the server using a client application, such as NerveCenter Client and NerveCenter Administrator. For these applications and a NerveCenter Server to communicate, they must use the same port connection.

By default, NerveCenter Server communicate on the special port 32504. If for some reason—such as this port is being used by another application—it becomes necessary to change NerveCenter's communication port, an administrator may do so. However, the administrator must follow *all* of these procedures:

- ♦ [Configuring the NerveCenter Server Connection Port on page 80](#)
- ♦ [Changing the NerveCenter Administrator's Server Port on page 82](#)
- ♦ [Changing the NerveCenter Client's Server Port on page 83](#)

**CAUTION**

Any application attempting to communicate with a NerveCenter Server must have a matching communication port number.

Configuring the NerveCenter Server Connection Port

The NerveCenter Server communicates with other applications, such as NerveCenter Client and NerveCenter Administrator, on a special connection port.

By default, this port number is 32504.

TO CHANGE THE NERVECENTER SERVER CONNECTION PORT

1. Open NerveCenter Administrator and connect to the appropriate Server.
See *Connecting Administrator to a NerveCenter Server on page 44*.
2. Select the **Ports** tab.
The Ports tab is displayed.

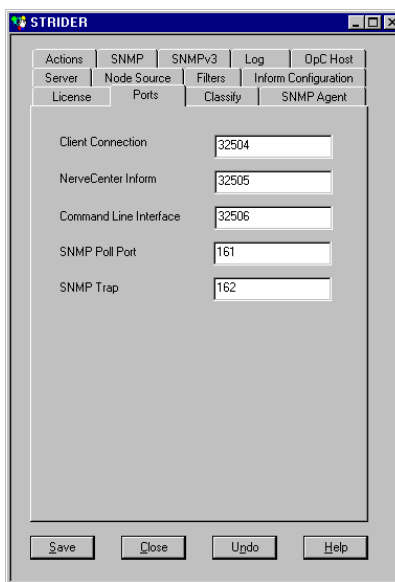

3. In the **Client Connection** field, enter the port number you want the NerveCenter Server to use for client/server communication.

**CAUTION**

Remember the port number. If you change it here, you must make corresponding changes to the NerveCenter Client and NerveCenter Administrator.

4. Select **Save**.
5. Stop and start the NerveCenter Server.

Changes to the communication port will not be complete until the NerveCenter Server is restarted. See *Running the NerveCenter Server on page 37*.

NerveCenter uses the specified port when connecting with any NerveCenter Administrator or Client.

Changing the NerveCenter Administrator's Server Port

If you change a NerveCenter Server's communication port number, be sure all applications, such as NerveCenter Administrator, have a matching port number.

TO CHANGE THE NerveCenter ADMINISTRATOR'S SERVER PORT

1. Open NerveCenter Administrator. See *Starting NerveCenter Administrator on page 42*.
2. From the **Admin** menu, choose **Configuration**.

The NCAAdmin Configuration window appears.

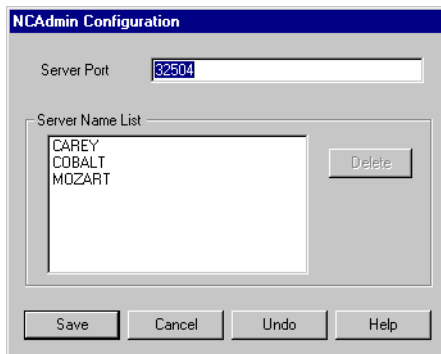

The NCAAdmin Configuration window displays the Server port the NerveCenter Administrator application uses to communicate with a NerveCenter Server. It also includes a list of all the servers this application has connected to in the past.

3. In the Server Port field, type the connection port number of the NerveCenter Server you want the NerveCenter Administrator application to connect to.



CAUTION

Remember the port number. If you change it here, you must make corresponding changes to the NerveCenter Server.

4. Select **Save**.
-

The NerveCenter Administrator application will now communicate with the NerveCenter Server at the new port you specified in the Server Port field.

Changing the NerveCenter Client's Server Port

If you change a NerveCenter Server's communication port number, be sure all applications, such as NerveCenter Client, have a matching port number.

TO CHANGE THE NerveCenter CLIENT'S SERVER PORT

1. Open NerveCenter Client.
See *Starting the Client in Designing and Managing Behavior Models* for more details.
2. In the **Client** menu, choose **Configuration**.
The Client Configuration window appears.

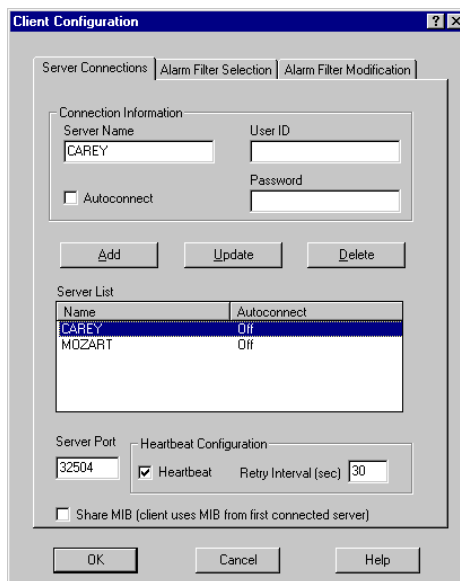

3. Select the **Server Connections** tab.
4. From the server list, select the appropriate server.
The server's current port number appears in the Server Port field.

5. In the Server Port field, type the connection port number of the NerveCenter Server you want the NerveCenter Client application to connect to.

**CAUTION**

Remember the port number. If you change it here, you must make corresponding changes to the NerveCenter Server.

6. Select **Save**.
-

The NerveCenter Client application will communicate with the NerveCenter Server at the new port you specified in the Server Port field.

Configuring NerveCenter to Receive Inform Actions

Once a NerveCenter behavior model detects a problem, it can notify a network management platform of the problem using the Inform action. This action sends an inform packet to its recipients, indicating the nature of the problem.

**NOTE**

Although the message that the Inform action sends to its recipients contains the same information as a trap, the message is not sent via UDP. An inform message is sent via TCP to make sure the delivery mechanism is reliable.

In addition to sending an Inform to network management platforms, a NerveCenter Server can send an Inform to another NerveCenter Server or itself.

Before a NerveCenter Server can receive a trap it must be configured to have a listening port number. By default, this port number is 32505.

TO SPECIFY THE PORT NERVECENTER SERVER USES TO RECEIVE AN INFORM PACKET

1. Open NerveCenter Administrator and connect to an appropriate NerveCenter Server. See [Connecting Administrator to a NerveCenter Server on page 44](#).
2. Select the **Ports** tab.

The Ports tab is displayed.

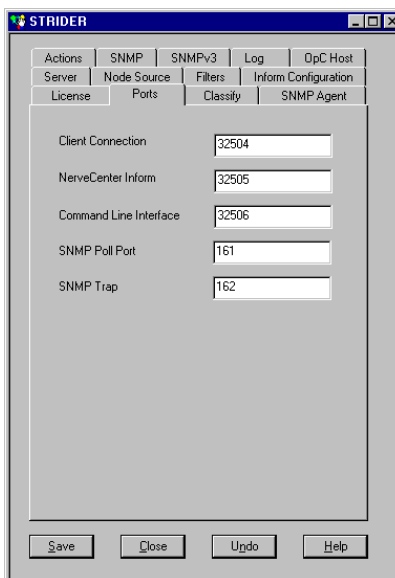

3. In the NerveCenter **Inform** field, type the number of the port through which this NerveCenter Server should receive inform packets sent by a NerveCenter Server.
4. Select **Save**.
5. Stop and start the NerveCenter Server.

Changes to the Inform port will not be complete until the NerveCenter Server is restarted. See [Running the NerveCenter Server on page 37](#).

The current NerveCenter Server will receive Inform packets from other NerveCenter Servers at the port specified.

TO VIEW NERVECENTER SERVERS CONFIGURED TO SEND INFORMS TO THE CURRENT SERVER

1. From the **Server** menu in the Administrator or Client, choose **Server Status**.
 2. Select the **Connected** NerveCenters tab.
-

Any NerveCenter Server configured to send an inform packet to the current NerveCenter Server at the port specified in step 3 appears in the Inform NC Name list.

Changing the Command Line Interface Port

You can use NerveCenter's command line interface to delete, list, or set (enable or disable) alarms, trap masks, nodes, and polls from a Windows Command Prompt or a UNIX shell. You can also connect to, display the status of, and disconnect from NerveCenter servers using the CLI. You can issue commands manually or from a script.

TO SPECIFY THE NERVECENTER COMMAND LINE INTERFACE PORT

1. Open NerveCenter Administrator and connect to an appropriate NerveCenter Server. See [Connecting Administrator to a NerveCenter Server on page 44](#).

2. Select the **Ports** tab.

The Ports tab is displayed.

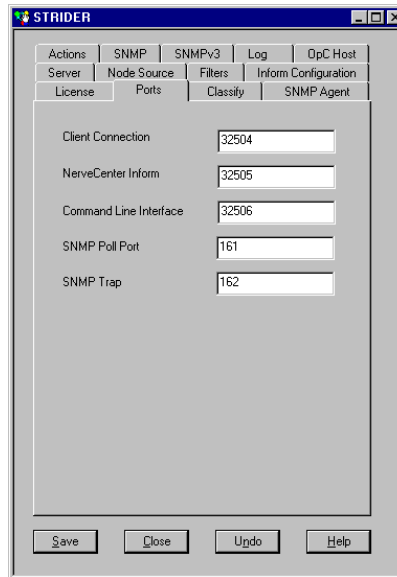

3. In the Command Line Interface field, enter the number of the port through which this NerveCenter Server should receive commands from its Command Line Interface.
4. Select **Save**.

The current NerveCenter Server will receive commands from the port specified.

Specifying SNMP Ports for NerveCenter

NerveCenter has two primary sources of information about network conditions:

- ◆ NerveCenter listens passively for SNMP traps sent by a managed device.
- ◆ NerveCenter actively polls the SNMP agents on a managed device.

You can change the ports that NerveCenter uses for receiving traps and sending polls.

TO SPECIFY NERVECENTER SNMP PORT SETTINGS

1. Open NerveCenter Administrator and connect to the appropriate NerveCenter Server. See [Connecting Administrator to a NerveCenter Server on page 44](#).

2. Select the **Ports** tab.

The Ports tab is displayed.

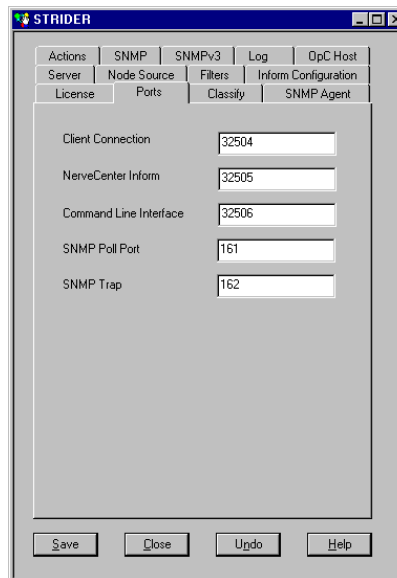

The screenshot shows the STRIDER application window with the 'Ports' tab selected. The window contains several input fields for configuring ports:

Field	Value
Client Connection	32504
NerveCenter Inform	32505
Command Line Interface	32506
SNMP Poll Port	161
SNMP Trap	162

At the bottom of the window, there are four buttons: Save, Close, Undo, and Help.

3. In the SNMP Poll field, enter the number of the port you want NerveCenter to use to communicate with SNMP agents. This port is used to get or set SNMP information.

The value entered here specifies the port on the node to which NerveCenter sends SNMP polls. You can change the port for any particular node in the node's definition window in NerveCenter Client.

OpenService recommends that you keep the default port number 161.

4. In the SNMP Trap field, enter the number of the port you want NerveCenter to use for receiving SNMP traps. This setting has no effect if NerveCenter is co-resident with HP OpenView Network Node Manager. OpenView has the trap port and an internal NerveCenter process enables NerveCenter to receive a copy of the trap.

The default port number is 162.

**NOTE**

You must shut down and restart the NerveCenter Server before the SNMP Trap port change takes effect.

If you want to capture SNMP v3 traps, the SNMP Trap port must be free for NerveCenter to capture the traps. This requires that you shut down MS Trap service or OVTrapD. If both are on your system, shut down both.

5. Select **Save**.

NerveCenter handles SNMP data according to these settings.

Troubleshooting: Managing NerveCenter Port Connections

The following list contains some common problems users have when managing the NerveCenter Server port connections.

The NerveCenter Server's communication port does not change when I selected Save in NerveCenter Administrator

Problem: NerveCenter must register the changes.

Solution: Stop and start the NerveCenter Server.

See *Running the NerveCenter Server on UNIX on page 38* or *Running the NerveCenter Server on Windows on page 39*.

A NerveCenter Server does not receive Informs sent by another NerveCenter Server

Problem: The inform packet is being sent to an incorrect port.

Solution: Make sure the receiving NerveCenter Server's inform port is the same as the port in the sending NerveCenter's inform configuration.

See *Configuring NerveCenter to Receive Inform Actions on page 84*.

The NerveCenter Server's inform port did not change when I selected Save in NerveCenter Administrator

Problem: NerveCenter must register the changes.

Solution: Stop and start the NerveCenter Server.

See *Running the NerveCenter Server on UNIX on page 38* or *Running the NerveCenter Server on Windows on page 39*.

To detect and correlate network events, NerveCenter must have basic information about each of the managed nodes it is monitoring. It stores this data in a node list in NerveCenter's database. As an administrator you will need to determine which nodes belong in NerveCenter's node list. You will also be responsible for keeping the node list complete and current. This chapter describes the NerveCenter tools you can use to carry out these tasks.



NOTE

NerveCenter can only obtain data from managed nodes running active Simple Network Management Protocol (SNMP) agents.

This chapter includes the following sections:

Section	Description
<i>How NerveCenter Manages Nodes on page 92</i>	Describes the tasks that NerveCenter performs to automate event handling.
<i>NerveCenter's Node List on page 102</i>	Explains that NerveCenter stores basic information about each node it will monitor in a node list in the NerveCenter database.
<i>Filtering Nodes on page 103</i>	Explains how to specify which managed nodes NerveCenter is responsible for monitoring.
<i>Processing Traps from Unknown Nodes on page 113</i>	Explains how to configure NerveCenter to receive and process traps from nodes not included in its node list.
<i>Initially Populating the Node List on page 115</i>	Explains the methods used to populate NerveCenter's node list with initial node data.
<i>Maintaining the Node List on page 123</i>	Explains the various ways nodes can be added to and deleted from NerveCenter's database.
<i>Troubleshooting: Managing node data on page 129</i>	Lists common problems NerveCenter users may face when managing node data.

How NerveCenter Manages Nodes

The following sections describe the tasks that NerveCenter performs to automate event handling:

- ◆ *Defining a Set of Nodes on page 92*
- ◆ *Detecting Conditions on page 93*
- ◆ *Correlating Conditions on page 93*
- ◆ *Responding to Conditions on page 98*

Defining a Set of Nodes

NerveCenter can get the list of devices to monitor from a network management platform, discover them on the network, or import this information from another NerveCenter database.

NerveCenter assigns to each managed node a set of *properties*, and these properties determine which behavior models apply to a node. Properties typically describe the type of the device—for example, a router—or are named after objects in the management information base (MIB) used to manage the node.

Once NerveCenter assigns a set of properties to a node, NerveCenter automatically applies to that node all of the models that refer to those properties. If NerveCenter detects that a node has been deleted or that its properties have changed, the product immediately retires or updates the set of models that are actively managing that node. This dynamic process enables NerveCenter to adapt at once to changes in network configuration reported by the management platform or by NerveCenter's own discovery mechanism.

It is also possible to assign properties to nodes manually to further refine the set of models that NerveCenter uses to manage a node. For example, you may want to distinguish a backbone router from a campus router to regulate how much and how often status information is collected.

Detecting Conditions

NerveCenter can collect network and system data from a variety of sources. However, NerveCenter most frequently obtains data from Simple Network Management Protocol (SNMP) agents running on managed nodes. This means that NerveCenter detects most conditions by:

- ◆ Receiving and interpreting an SNMP trap
- ◆ Polling an SNMP agent for data and analyzing that data

One of the criticisms of SNMP-based enterprise management platforms over the years has been that, because SNMP trap delivery is unreliable, the platform must poll agents and this polling generates too much network traffic. NerveCenter helps alleviate this problem by enabling you to determine the interval at which a poll is sent and to turn a poll off. Even more important is NerveCenter's *smart polling* feature. NerveCenter sends a poll to a node only if the poll:

- ◆ Is part of a behavior model designed to manage that node
- ◆ Can cause a change in the alarm's state

Also, because of NerveCenter's client/server architecture, NerveCenter servers can be distributed so that all polling is done on LANs, and not across a WAN. Furthermore, use of SNMP v2c and v3 features allow SNMP to be utilized both reliably and securely.

Correlating Conditions

Event correlation involves taking a number of detected network conditions and determining:

- ◆ How these conditions, or some subset of them, are related
- ◆ The underlying cause, or the problem to which these conditions have led

For instance, NerveCenter may look at a large number of events and identify a subset of events that relate to SNMP authentication failures on a managed node. NerveCenter may then determine that the authentication failures were far enough apart that no problem exists, or it may find that several failures occurred within a short period of time, indicating a possible security problem. In the latter case, NerveCenter might notify administrators of the potential problem. In this way, administrators receive one notice about a potential security problem rather than having to browse through a long list of detected conditions and identify the problem themselves.

Detected conditions can be correlated in many ways. In fact, once you start working with NerveCenter, you will help determine how these conditions are correlated yourself. However, there are some typical ways in which NerveCenter finds relationships between conditions.

Several of these methods are discussed in the following sections:

- ♦ *Detecting the Persistence of a Condition on page 94*
- ♦ *Finding a Set of Conditions on page 95*
- ♦ *Looking for a Sequence of Conditions on page 96*

Detecting the Persistence of a Condition

Probably the simplest method of correlating detected conditions is to search for the persistence of a problem. For example, a network administrator might want to know if an SNMP agent sends a link-down trap and that trap is not followed within three minutes by a link-up trap. NerveCenter can track such a link-down condition using a state diagram similar to the one shown in *Figure 8-1*.

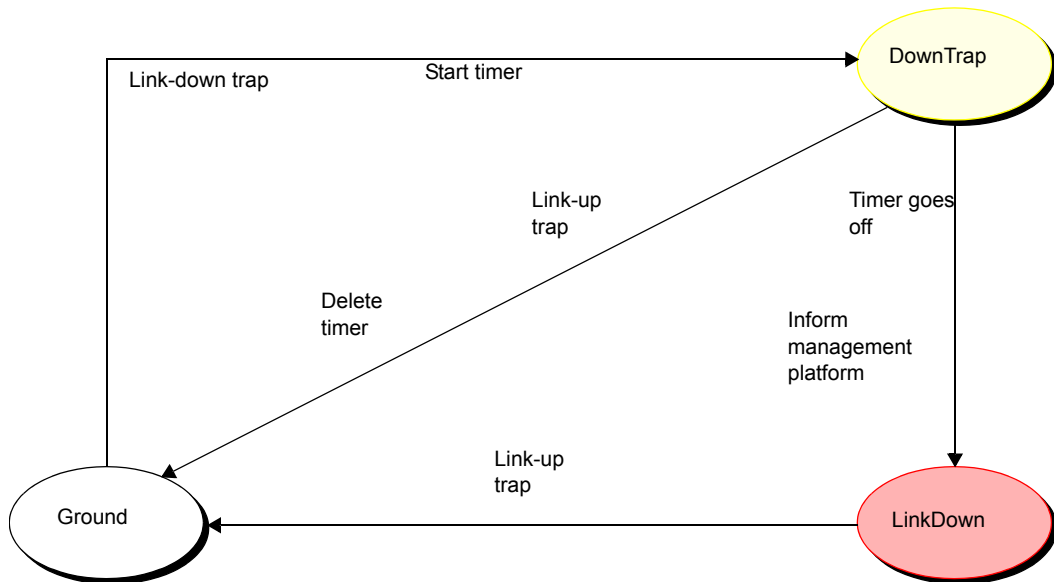

FIGURE 8-1. State Diagram for Detecting a Link-Down Condition

If NerveCenter has this state diagram in memory and is tracking a particular interface for a link-down condition.

- ◆ The first time NerveCenter sees a link-down trap concerning that interface, the current state becomes DownTrap, and NerveCenter starts a three-minute timer.
- ◆ If NerveCenter receives a link-up trap within three minutes of the link-down trap, the current state reverts to Ground (normal) because NerveCenter is looking for a *persistent* link-down condition. In addition, NerveCenter stops the timer. However, if three minutes expire before a link-up trap arrives, the current state becomes LinkDown, and NerveCenter informs a network management platform that the link is down.
- ◆ The current state remains LinkDown until a link-up trap does arrive. At that point, the current state reverts to Ground, and the process begins again.

Finding a Set of Conditions

Another common type of event correlation is identifying a set of conditions. For example, when monitoring the interfaces on a router, you might use the state diagram in [Figure 8-2](#) to be notified when a low-speed or high-speed interface goes down.

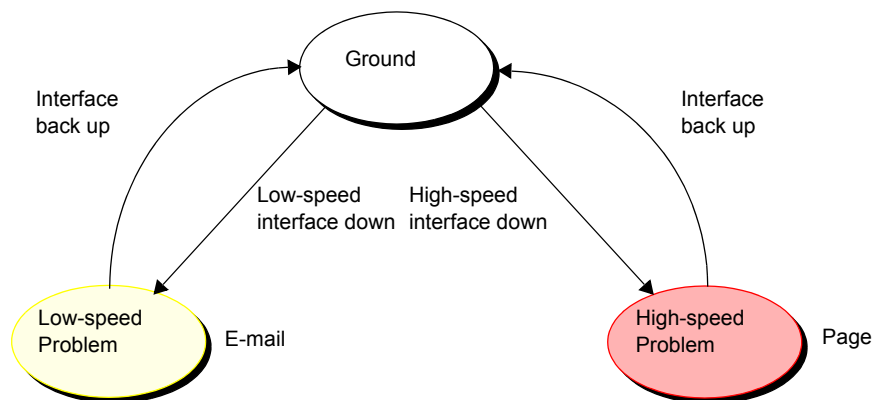

FIGURE 8-2. State Diagram for Detecting a Router Interface Problem

What causes state transitions in this situation? NerveCenter can poll the SNMP agent on the router for the values of the following interface attributes: ifOperStatus, ifAdminStatus, ifSpeed, ifInOctets, and ifOutOctets.

If the poll successfully returns values for these attributes, NerveCenter can then evaluate the expression shown below in pseudocode:

```
if ifOperStatus is down && ifAdminStatus is up &&
(ifInOctets > 0 || ifOutOctets > 0)
    if ifSpeed < 56K
        move to lowSpeedProblem state
    else
        move to highSpeedProblem state
    else
        move to ground state
```

This code is looking for two sets of conditions. The first set is:

- ◆ The operational state of the interface is down.
- ◆ The administrative status of the interface is up.
- ◆ Traffic has been passed on this interface. (If no traffic has been passed, the interface is just coming up.)
- ◆ The interface's current bandwidth is less than 56K.

If these conditions are met, a problem exists on an interface that is likely used for dial-up connections. The second set of conditions is the same except for the last condition, which checks whether the interface's current bandwidth is greater than or equal to 56K. If this second set of conditions is met, a problem exists on a higher speed interface. If neither of these sets of conditions is met, the current state should return to, or remain at, Ground.

NerveCenter may detect many conditions concerning an interface before it finds the set of conditions it is looking for. The administrator need not see information about each of these conditions. He or she will be emailed or paged if the interface goes down.

Looking for a Sequence of Conditions

NerveCenter also enables correlation by looking for sequences of conditions. This type of correlation is possible because, each state in a state diagram can look for a different set of conditions. For instance, let's look at a state diagram that NerveCenter uses to track the status of a node and its SNMP agent. The diagram (*Figure 8-3*) includes states for the following conditions:

- ◆ The node and its SNMP agent are up.
- ◆ The node is up, but its agent is down.
- ◆ The node is unreachable.
- ◆ The node is down.

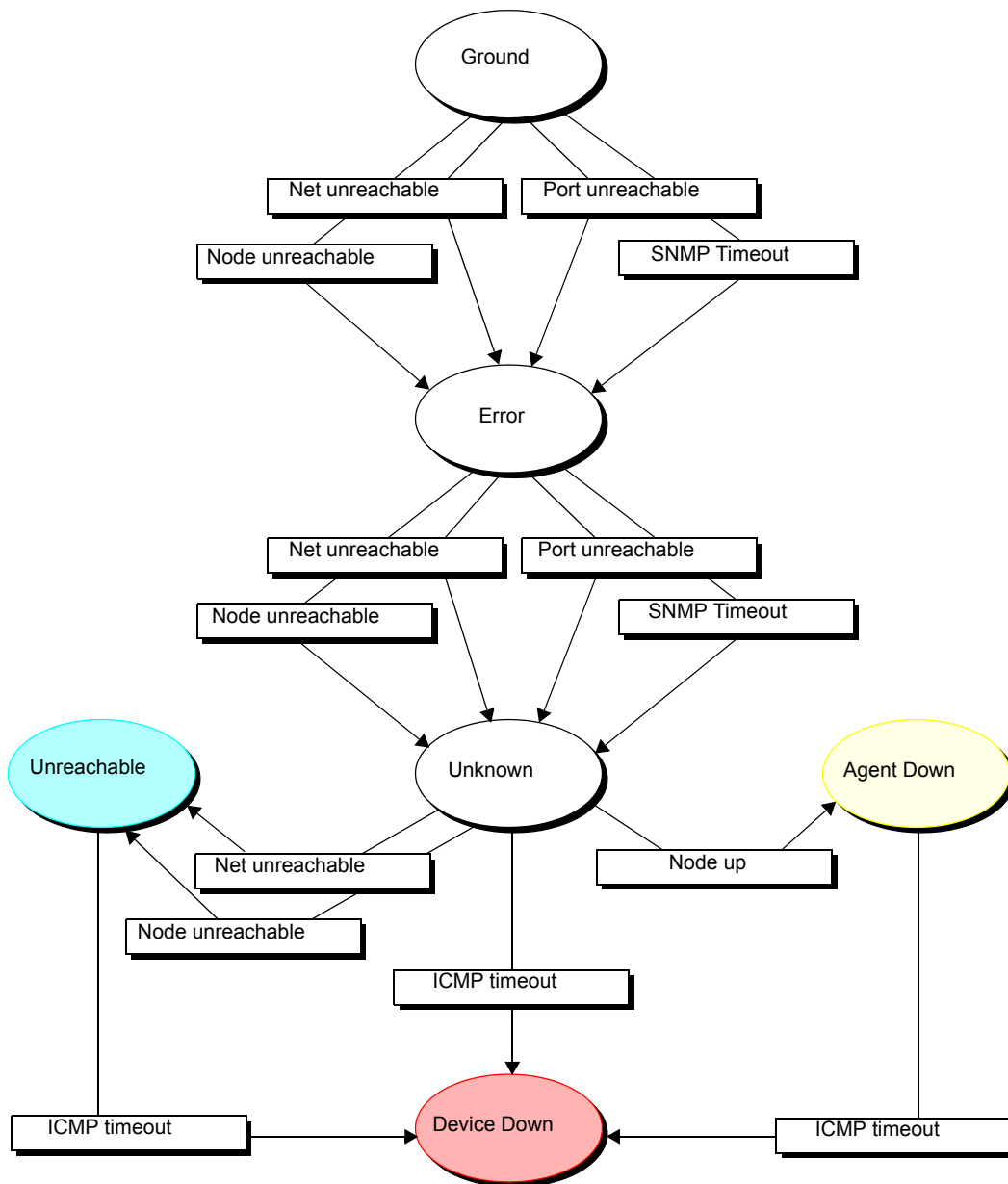

FIGURE 8-3. State Diagram for Determining Node Status

**NOTE**

A more realistic state diagram for tracking the status of a node would include transitions from the terminal problem states back to Ground.

When checking the status of a node and its SNMP agent, NerveCenter begins by polling the node to see if the node's SNMP agent will return the value of the MIB attribute sysObjectID. If the agent returns this value, the current state remains Ground. However, NerveCenter makes Error the current state if:

- ◆ The node, or the network the node is on, is unreachable
- ◆ The node is reachable, but the SNMP agent doesn't respond

Similarly, NerveCenter changes the current state to Unknown if it detects for a second time that the node is unreachable or the node's SNMP agent isn't responding.

Once the current state becomes Unknown, though, NerveCenter begins looking for a different set of conditions. NerveCenter checks to see whether the node will respond to an ICMP ping. If it will, NerveCenter knows that the node is up, but its SNMP agent is down. If it receives another network- or node-unreachable message, NerveCenter knows that the node is unreachable. And if the ping times out, NerveCenter knows that the node is down.

This ability of different states to monitor different conditions gives you the ability to correlate *sequences* of conditions. That is, a sequence of two SNMP timeouts followed by a Node up indicates that the node is up but its agent is down. And a sequence of two Node unreachables followed by an ICMP timeout indicates that the node is down.

Responding to Conditions

NerveCenter not only enables you to detect network and system problems, but is able to respond automatically to the conditions it detects. To set up these automated responses, you associate *actions* with state transitions.

The possible actions you can define are discussed in the following sections:

- ◆ *Notification on page 99*
- ◆ *Logging on page 99*
- ◆ *Causing State Transitions on page 100*
- ◆ *Corrective Actions on page 100*
- ◆ *Action Router on page 101*

Notification

If a particular network or system condition requires the attention of an administrator, the best action to take in response to that condition is to notify the appropriate person. NerveCenter lets you notify administrators of events in the following ways:

- ◆ You can send an audible alarm (a beep) to workstations running the NerveCenter Client.
- ◆ You can send email to an administrator using either a Microsoft Exchange Server client or SMTP mail.
- ◆ You can page an administrator.
- ◆ You can send information about a network or system condition to another NerveCenter server. This capability is useful if you have a number of NerveCenter servers at different sites and want these servers to forward information about important events to a central server.
- ◆ You can send information about a network or system condition to a network management platform such as IBM Tivoli's Netcool/OMNIBus or Hewlett Packard's OpenView Network Node Manager. Administrators can then be notified of a problem found by NerveCenter using the other management tool's console.

For more information on integrating NerveCenter with other network management products, see the section *Role in Network Management Strategy on page 29*.

Logging

If you want to keep a record of an event that takes place on your network, you must explicitly log information about the event at the time it occurs. NerveCenter provides three actions that provide for such logging:

- ◆ Log to File
- ◆ Log to Database (Windows only)
- ◆ EventLog

Log to File writes information about an event to a file. Log to Database writes information about an event to the NerveCenter database. The EventLog action writes information about an event to an event or system log.

When you assign a logging action to a behavior model, you have the choice of logging default data or customizing what data you deem relevant. This saves disk space and streamlines information used later for analysis and reporting.

Causing State Transitions

In some behavior models, one alarm needs to cause a transition in another. The action that enables such communication between alarms is called Fire Trigger. This action creates a NerveCenter object called a trigger that can cause a state transition in the alarm from which it was fired or in another alarm.

The Fire Trigger action also lets you specify a delay, so you can request that a trigger be fired in one minute or five hours. This feature is especially useful when you're looking for the persistence of a condition. Let's say that you want to look for three intervals of high traffic on an interface within a two-minute period. When your poll detects the first instance of high traffic, and your alarm moves out of the Ground state, you can fire a trigger with a two-minute delay that will return your alarm to the Ground state—unless a second and third instance of high traffic are detected.

If a third instance of high traffic is detected, you should cancel the trigger you fired on a delayed basis. You do this by adding the Clear Trigger action to the transition from the second high-traffic state to the third.

NerveCenter also includes a Send Trap action. You define the trap to be sent, including the variable bindings, and associate the action with a state transition. When the transition occurs, the trap is sent. The trap can be caught by a NerveCenter trap mask—in which case you can use Send Trap somewhat like Fire Trigger, to generate a trigger—or by any application with SNMP traps.

Corrective Actions

There are a number of NerveCenter actions that you can use to take corrective actions when a particular state transition occurs. These are:

- ◆ Command
- ◆ Perl Subroutine
- ◆ Set Attribute
- ◆ Delete Node
- ◆ SNMP Set

The Command action enables you to run a script or executable when a particular transition occurs.

The Perl Subroutine action enables you to execute a Perl script as a state-transition action. You first define a collection of Perl scripts and store them in the NerveCenter database; then, you choose one of your stored scripts for execution during a state transition.

The Set Attribute action enables you to set selected attributes of the NerveCenter objects used to build behavior models.

The Delete Node action deletes the node associated with the current state machine from the NerveCenter database. This action is useful if you use a behavior model to determine which nodes you want to monitor and manage.

The SNMP Set alarm action changes the value of a MIB attribute when an alarm transition occurs.

Action Router

The Action Router enables you to specify actions that should be performed when a state transition occurs *and other conditions are met*. To set up these conditional actions, you add the Action Router action to your state transition. Then, you use the Action Router tool to define rules and their associated actions.

For example, let's assume that you want to be notified about a state transition only if the transition puts the alarm in a critical state. You can define the following rule:

```
$DestStateSev eq 'Critical'
```

Then define the action you want taken if the severity of the destination state is Critical, for example, a page. You will be paged if:

- ◆ The Action Router action is associated with the current state transition
- ◆ The destination state for the transition is Critical

Action Router rules can be constructed using many variables that NerveCenter maintains; for instance, you can also construct rules based on:

- ◆ The name of the alarm
- ◆ The day of the week
- ◆ The time of day
- ◆ The name or IP address or group property of the node being monitored
- ◆ The name of the trigger that caused the state transition
- ◆ The name of the alarm's property
- ◆ The name or severity of the origin state
- ◆ The contents of a trap
- ◆ The contents of an IT/Operations message
- ◆ The contents of the varbind data associated with a trap or a poll

NerveCenter's Node List

To detect and correlate network events, NerveCenter must have basic information about each managed node it monitors. NerveCenter obtains this data through several means.

NerveCenter can obtain node information from any or all of the following sources:

- ◆ A network management platform, such as HP OpenView Network Node Manager
- ◆ The NerveCenter Discovery behavior model
- ◆ An administrator's manual entries



NOTE

Though NerveCenter supports SNMP v1, v2c, and v3, when NerveCenter obtains nodes from a platform, the platform does not provide SNMP version information. By default, NerveCenter deems the SNMP agents on these nodes to be SNMP v1.

If you want NerveCenter to attempt SNMP version classification automatically for the nodes it receives from your platform, you must enable auto-classification. Then, NerveCenter can classify the correct SNMP version for each node with each resynchronization. Refer to [Managing SNMP Settings on page 133](#) for more information about SNMP auto-classification.



NOTE

To manage SNMP v3 nodes, you must use NerveCenter as your trap source regardless of the node source you configure. Refer to [Changing the SNMP Trap Source on page 56](#) for more information about the SNMP trap source.

When NerveCenter uses information obtained by a network management platform, it does not use the platform's database as its repository for managed nodes. Instead, it stores node information in its own database in a node list.

There are a few reasons for NerveCenter maintaining a node list in its own database:

- ◆ There may be a considerable distance between the platform's database and NerveCenter, making frequent access time-consuming and costly.
- ◆ NerveCenter adds configuration data to the node data that the management platform does not necessarily provide.
- ◆ Administrators have the option of adding nodes not in the platform's node database to the node list in NerveCenter's database.

Filtering Nodes

Before populating the node list in NerveCenter's database, it is important to determine which nodes NerveCenter will manage, as NerveCenter does not need to monitor every node on your network. There are a few methods for restricting which nodes will be placed in NerveCenter's node list:

- ◆ *Filtering Using a Node's Capabilities on page 103*
- ◆ *Filtering Using a Node's System Object Identifier on page 104*
- ◆ *Filtering Nodes by IP Address on page 105*
- ◆ *Filtering Nodes by Hostnames on page 110*

Filtering Using a Node's Capabilities

You can monitor nodes with particular capabilities, which your network management system typically assigns to a node to determine the applicable activities such as isRouter, isHub, and isIP.

**NOTE**

Filtering by capabilities is available only when your network management platform has assigned specific capabilities to a node.

TO FILTER USING A NODE'S CAPABILITIES

1. Open NerveCenter Administrator and connect to the appropriate NerveCenter Server.
See the section *Connecting Administrator to a NerveCenter Server on page 44*.
2. Select the **Node Source** tab.
3. In the **Wanted Capabilities** field, type the name of the specific capability desired.
If this field is left blank, NerveCenter will not filter using a node's capability.
4. To enter multiple capabilities, separate each with a space.
NerveCenter will monitor any node that matches at least *one* of the capabilities in the list.
5. Select **Save**.
The NerveCenter Server adds the new capabilities filter. It also closes and opens a new connection with the platform adapter. NerveCenter automatically resynchronizes with your

network management platform database. New nodes will be added. Any node that is marked Autodelete (the default) will be deleted.

Filtering Using a Node's System Object Identifier

NerveCenter allows you to monitor managed nodes according to their particular system object identifiers (OIDs). A node's System Object ID is an SNMP MIB-II object in the system group. It identifies the SNMP agent software running on the device. It is, however, commonly used to identify the type and vendor of the device because a particular vendor's agent usually runs on that vendor's devices.

TO FILTER USING A NODE'S SYSTEM OBJECT IDENTIFIER

1. Open NerveCenter Administrator and connect to the appropriate NerveCenter Server.

See *Connecting Administrator to a NerveCenter Server on page 44*.

2. Select the **Node Source** tab.
3. In the **System Object Ids** field, type the name of the system OID wanted.

If this field is left blank, NerveCenter will not filter using a node's system OID.

4. To enter multiple OIDs, separate each with a space.

NerveCenter will monitor any node that matches at least *one* of the OID in the list.

For example, an administrator may want to restrict NerveCenter to nodes running SNMP agents from either Cisco or Hewlett-Packard nodes by typing the following:

```
1.3.6.1.4.1.9 1.3.6.1.4.1.11
```

Any device with an OID matching either of these numbers will be included in the NerveCenter nodes database.

5. Select **Save**.

The NerveCenter Server adds the new OID filter. It also closes and opens a new connection with the platform adapter. NerveCenter automatically resynchronizes with your network management platform's database. New nodes will be added. Any node that is marked Autodelete (the default) will be deleted.

Filtering Nodes by IP Address

In addition to filtering nodes by OIDs and capabilities, NerveCenter allows you to filter out all nodes that do not belong to one or more subnets. NerveCenter determines the subnet by combining a specific IP address with a subnet mask. NerveCenter can filter by subnets of both Class B and Class C networks. In Class B networks, the first two octets specify the network while in Class C networks the first three octets identify the network.

Table 8-1 and *Table 8-2* illustrate some filter configurations and their results:

TABLE 8-1. Sample Subnet Filters and Their Results for a Class C Network

IP address	Subnet mask	Result
134.204.179.0	255.255.255.0	All nodes on subnet 134.204.179.0 are included. For example, 134.204.179.7 is included.
197.22.44.0	255.255.255.240	All nodes 1-15 on subnet 197.22.44.0 are included. For example, 197.22.44.5 is included but 197.22.44.35 is excluded.
134.204.179.0 197.22.44.0	255.255.255.0 255.255.255.240	All nodes on subnets 134.204.179.0 and nodes 1-15 on 197.22.44.0 are included. For example, both 134.204.179.7 and 197.22.44.5 are included.

TABLE 8-2. Sample Subnet Filters and Their Results for a Class B Network

IP address	Subnet mask	Result
132.45.0.0	255.255.0.0	All nodes on subnet 132.45.0.0 are included. For example, 132.45.174.7 is included.
132.45.0.0	255.255.240.0	Nodes 1.0 - 15.255 are included. For example 132.45.14.231 is included but 132.45.174.7 is excluded.

In addition to filtering out all but an entire subnet, NerveCenter allows you to exclude a specific node or range of nodes within the remaining subnet.

Table 8-3 illustrates some filter configurations with exclusions and their results:

TABLE 8-3. Sample Subnet Filters with Exclusions and Their Results

IP address	Subnet mask	Excluded node(s)	Result
134.204.179.0	255.255.255.0	40	All nodes on subnet 134.204.179.0 except node 40 are include. For example, 134.204.179.7 is included but 134.204.179.40 is excluded.
134.204.179.0	255.255.255.0	40-55	All nodes on subnet 134.204.179.0 except nodes 40-55 are include. For example, 134.204.179.7 is included but 134.204.179.40 and 134.204.179.52 are excluded.
132.45.0.0	255.255.0.0	63.5	All nodes on subnet 132.45.0.0 except node 63.5 are included.



NOTE

You can filter nodes that have been discovered by NerveCenter, provided by the platform node source, or imported from a node file.

NerveCenter can automatically or manually determine the subnet criteria used to filter nodes by IP address.

TO CONFIGURE NERVECENTER TO DETERMINE SUBNET CRITERIA AUTOMATICALLY

1. Open NerveCenter Administrator and connect to the appropriate NerveCenter Server.
See *Connecting Administrator to a NerveCenter Server on page 44*.
2. Select the **Filters** tab.
The Filters tab is displayed.

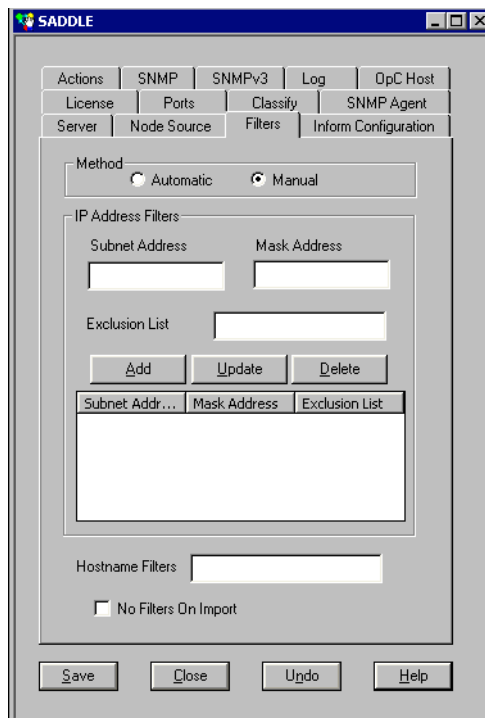

3. In the Method area, select **Automatic**.
Setting the method to automatic tells NerveCenter to ignore any address filters you enter and use instead the server's masks as a filter. NerveCenter calculates the subnet address and mask using the IP address and mask of each network interface card on the server.
 4. Select **Save**.
NerveCenter will now automatically use the server's masks as a filter.
-

TO SET THE SUBNET CRITERIA MANUALLY

1. Open NerveCenter Administrator and connect to the appropriate NerveCenter Server.
See *Connecting Administrator to a NerveCenter Server on page 44*.
2. Select the **Filters** tab.
The Filters tab is displayed.

3. In the Method area, select **Manual**.

When the method is set to manual, NerveCenter will only use the subnet addresses listed in IP Address Filters area. If the IP Address Filters list is empty, NerveCenter ignores a node's subnet when determining if the node will be part of the node database.

4. In the **Subnet Address** field, type the appropriate subnet. In the **Mask Address** field, type the appropriate subnet mask.

A node's subnet address combines the node's IP address with the subnet mask.

- In the Exclusion List field, enter all the nodes you want excluded from the subnet address. To exclude more than one node, separate each number with a comma without a space. To exclude a continuous range of nodes, use a hyphen to separate the minimum and maximum number by a hyphen.



CAUTION

Once you have added a node using the IPSweep behavior model, you cannot use an IP exclusion to delete it from the database. Once the node is in the database, the IP exclusion filter is not applied to it. The IP exclusion applies only to new nodes discovered after the filter is established.

- Select **Add**.

The subnet address and mask address will be added to the IP Address Filters list.

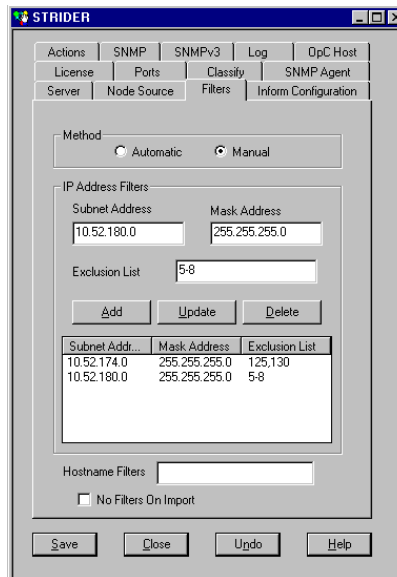

- Select **Save**.
- To filter by additional IP addresses and masks, repeat steps 4 and 7.

NerveCenter monitors any address falling within the subnet and not excluded by the filter.

Filtering Nodes by Hostnames

In addition to filtering nodes by OIDs, capabilities, and IP Addresses, NerveCenter allows you to filter out nodes by hostname. Filtering by hostname works in conjunction with IP Filters. If a node matches on either an IP filter or a hostname filter, the node will be filtered.

The hostname filter restricts imported node lists and node source from OVPA. Nodes discovered by SNMP traps are not affected by hostname filters because discovered nodes do not always have hostname information.

TO CONFIGURE HOSTNAME FILTERS

1. Open NerveCenter Administrator and connect to the appropriate NerveCenter Server.

See [Connecting Administrator to a NerveCenter Server on page 44](#).

2. Select the **Filters** tab.

The Filters tab is displayed.

The screenshot shows the SADDLE Filters configuration window. The window title is "SADDLE". The interface includes a menu bar with the following items: Actions, SNMP, SNMPv3, Log, OpC Host, License, Ports, Classify, SNMP Agent, Server, Node Source, Filters (selected), and Inform Configuration. Below the menu bar, there is a "Method" section with two radio buttons: "Automatic" (unselected) and "Manual" (selected). The "IP Address Filters" section contains two input fields for "Subnet Address" and "Mask Address", an "Exclusion List" input field, and three buttons: "Add", "Update", and "Delete". Below these buttons is a table with three columns: "Subnet Addr...", "Mask Address", and "Exclusion List". The table is currently empty. The "Hostname Filters" section has an input field and a checkbox labeled "No Filters On Import" which is unchecked. At the bottom of the window are four buttons: "Save", "Close", "Undo", and "Help".

3. In the Hostname Filters field, enter the hostnames you want to exclude, separating names with a space.

You can use an asterisk (*) as a wild card. For example, ***server** filters out all hostnames ending with server and ***router*** filters out all hostnames containing the word router.

**NOTE**

There is no guarantee that OVPA or node lists will always provide fully qualified host names. Therefore, filtering by domain names may not work if the node list does not contain fully qualified hostnames.

4. Select **Save**.

NerveCenter now filters by hostnames.

Enabling and Disabling IP and Hostname Filters

You can define IP Address and hostname filters to limit what nodes you add to your NerveCenter node list. This is important when using discovery methods such as IPSweep, so that you do not try to include the entire internet. However, if you have a node list you want to import of known hosts you want to monitor, you may not want to apply the IP and Hostname filters.

IP filters apply to the following:

- ◆ Importing node lists
- ◆ Populating the node lists with a network management platform
- ◆ Discovering nodes from traps, if you select IP Filter from the Discover Nodes from Traps list on the Server tab.

Hostname filters apply to the following:

- ◆ Importing node lists
- ◆ Populating the node lists with a network management platform

You can disable IP and hostname filters if you do not want to use them for an import from a node list or management platform.

TO DISABLE IP AND HOSTNAME FILTERS

1. Open NerveCenter Administrator and connect to the appropriate NerveCenter Server.
See *Connecting Administrator to a NerveCenter Server on page 44*.
2. Select the **Filters** tab.
The Filters tab is displayed.

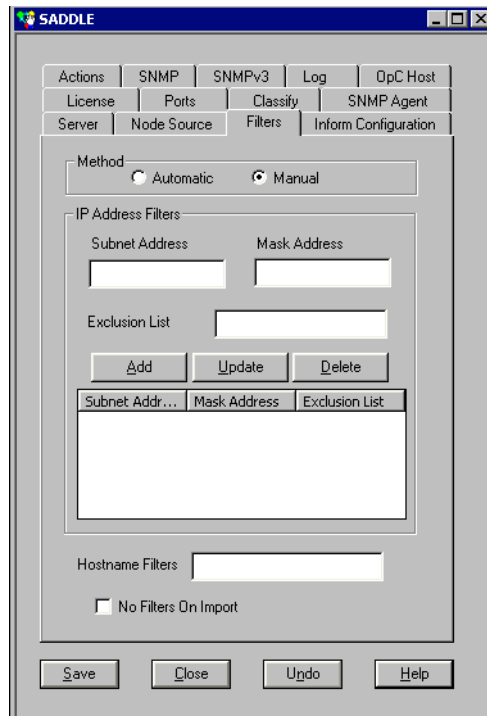

3. Select **No Filters On Import**.
4. Click **Save**.

When you are ready to continue using filters, you can easily enable IP and hostname filters.

TO DISABLE IP AND HOSTNAME FILTERS

1. Open NerveCenter Administrator and connect to the appropriate NerveCenter Server.
 2. Select the **Filters** tab.
The Filters tab is displayed.
 3. Clear **No Filters On Import**.
 4. Click **Save**.
-

Processing Traps from Unknown Nodes

NerveCenter offers a lot of flexibility in filtering the managed nodes it monitors. By setting node filters, you are telling NerveCenter to ignore any traps sent by nodes not stored in the node list. This keeps the node list to a size that is manageable and acceptable under your license agreement.

However, there may be times you will want a NerveCenter Server to process a trap from a node not found in its node list, but in the node list of another NerveCenter Server. For example, in the following diagram, a NerveCenter Server responsible for monitoring a LAN (Server A) needs to pass a trap along to a WAN-level NerveCenter Server (Server B).

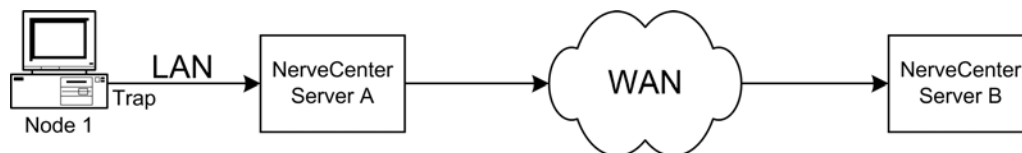

FIGURE 8-4. An Example of a Trap Being Processed from an Unknown Node

In this case, Node 1 is in the node list of Server A. Node 1 sends a trap to Server A, which in turn is passed along to Server B. Because Node 1 is being managed by Server A, it will not appear in Server B's node list. Server B needs to process the trap from Node 1. Server B could be set up to add unknown nodes to its node list whenever it receives a trap, but then both Server A and Server B will be monitoring Node 1. How can Server B process the trap from Node 1 without first adding the node to its node list?

The Process traps from unknown nodes feature allows a NerveCenter Server receiving a trap from an unknown node to process that trap if the trap is associated with an Enterprise scope alarm.

**NOTE**

The Process traps from unknown nodes feature will only process traps associated with Enterprise scope alarms.

At the same time, the Process traps from unknown nodes feature will keep the NerveCenter Server from adding the node to its node list. This ensures that the NerveCenter Server does not exceed the node limit allowed by its license. It also avoids a situation in which two NerveCenter Servers are responsible for the same node.

**NOTE**

To learn how a NerveCenter Server adds an unknown node to its node list when receiving a trap from that node, see [Adding Nodes Discovered from Traps on page 125](#).

TO PROCESS TRAPS FROM UNKNOWN NODES

1. Open NerveCenter Administrator and connect to the appropriate NerveCenter Server.
See [Connecting Administrator to a NerveCenter Server on page 44](#).
2. Select the **Server** tab.
NerveCenter displays the Server tab.

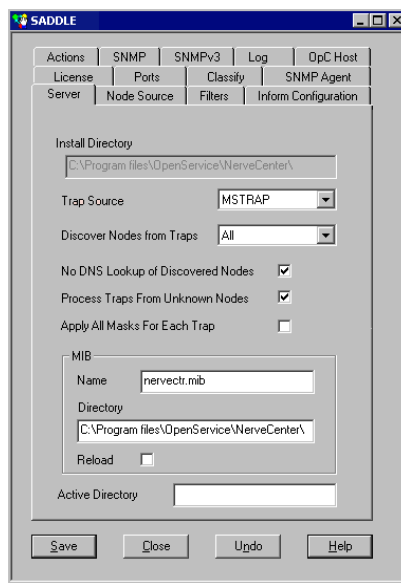

3. Select the **Process Traps From Unknown Nodes** box.

If this box is not selected, then NerveCenter will ignore any trap it receives from a node not included in its node list.

4. Select **Save**.

The NerveCenter Server will now process traps associated with Enterprise scope alarms even when those traps are received from nodes not appearing in the server's node list.

You can also use a Perl function, `AddNode()`, to add nodes to the NerveCenter database. See *AddNode() Function in Designing and Managing Behavior Models* for details.

Initially Populating the Node List

To detect and correlate network events, NerveCenter must have basic information about each of the managed nodes it monitors. Once you have configured the proper node filters (see *Filtering Nodes on page 103*), you must tell NerveCenter where to look for the initial data it will use to populate its node list.

Though you can manually add nodes to NerveCenter, it is easy to configure NerveCenter to discover nodes (*Figure 8-5*). When NerveCenter discovery is enabled, if the database does not already contain a node that sends it an SNMP trap or NerveCenter inform, NerveCenter adds that node to the database.

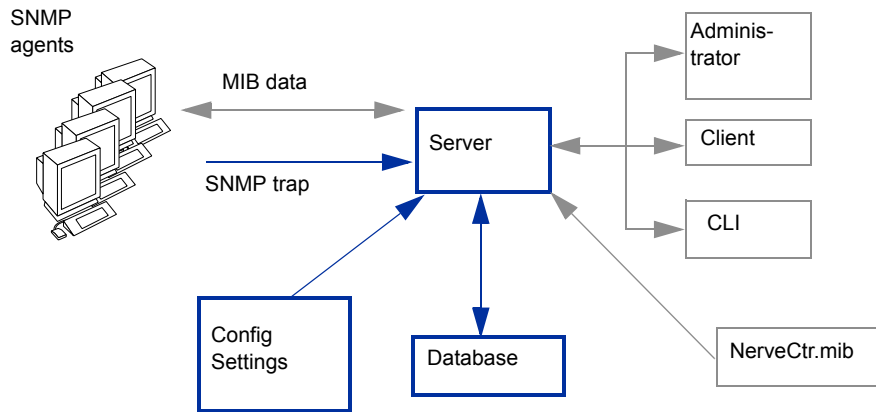

FIGURE 8-5. NerveCenter Configured To Discover Nodes

After installing NerveCenter, you can use the NerveCenter Administrator to define subnet IP filters that limit the sets of nodes NerveCenter can monitor. These filter values are stored with the NerveCenter configuration settings.

When a trap is received from a node, NerveCenter compares the node against those that are already in its database and confirms whether the node falls within the subnet IP filters you defined. Nodes that fall within the subnet range but are not in the database are added to the database.



NOTE

NerveCenter can be configured to process SNMP traps from nodes residing outside the defined subnet filters. These nodes, however, are not added to the database. See [Filtering Nodes by IP Address on page 105](#) for more details.

There are three main methods for populating NerveCenter's node list:

- ◆ [Populating Using a Network Management Platform as a Data Source on page 117](#)
- ◆ [Populating Using the IPSweep Behavior Model on page 119](#)
- ◆ [Populating the Node List Manually on page 122](#)

Populating Using a Network Management Platform as a Data Source

NerveCenter is able to receive information about some or all of the nodes managed by your network management platform. NerveCenter is able to retrieve data about managed nodes from the following HP OpenView Network Node Manager.

**NOTE**

To use your network management platform to populate NerveCenter's node database, you must have the NerveCenter OpenView Platform Adapter (OVPA) installed and running.

To populate NerveCenter's node list using your network management platform, you must specify it as a source for the node data. Each NerveCenter database populates its node list from just one network management platform database. Depending on your filtering, the database may contain all the nodes or just a subset. In either case, there is just one source of the information.

**CAUTION**

If you wish to map system Object Identifiers (OID) to NerveCenter property groups, you must make the necessary configurations in the NerveCenter Client before naming the node data source. (See *Using OID to Property Group Mappings in Designing and Managing Behavior Models*.) After NerveCenter initially populates its node list, any subsequent mapping of OIDs to property groups affect only new nodes added to the node list.

TO USE YOUR NETWORK MANAGEMENT PLATFORM AS A NODE DATA SOURCE

1. Open NerveCenter Administrator and connect to the appropriate NerveCenter Server.

See the section *Connecting Administrator to a NerveCenter Server on page 44*.

2. Select the **Node Source** tab.

NerveCenter displays the Node Source tab.

3. In the **Machine Name** field, type either the name or the IP address of a host that runs your network management platform.

For example, if you have your network management platform running on a machine named Norm, you would type the name **Norm** or its IP address in the Machine Name field.

If the Machine Name field is left blank, NerveCenter does not retrieve nodes from any platform.

4. In the **Port** field, type the number of the port used to communicate with the platform adapter process on the host. The default is 6024.

The platform adapter must be configured to listen on the same port specified in this field.

5. Select **Save**.

NerveCenter will now retrieve its initial node data from your network management platform's database. IP and hostname filters can apply to what node data is imported from the network management platform. See *Enabling and Disabling IP and Hostname Filters on page 111* for details about using filters with node lists.

Populating Using the IPSweep Behavior Model

There may be situations in which you will not want to use a network management platform to populate NerveCenter's node list initially. Such situations could include:

- ◆ Your network does not contain an applicable network management platform or you are using NerveCenter as a stand-alone application.
- ◆ A large distance or a costly link separates the platform from the nodes that NerveCenter will be monitoring locally.

For situations such as these, NerveCenter provides the IPSweep behavior model. Using the IPSweep behavior model, NerveCenter detects unknown nodes and adds them to the node database, provided they fall within the set filters. *Figure 8-6* shows how IPSweep fits in with the other NerveCenter components.

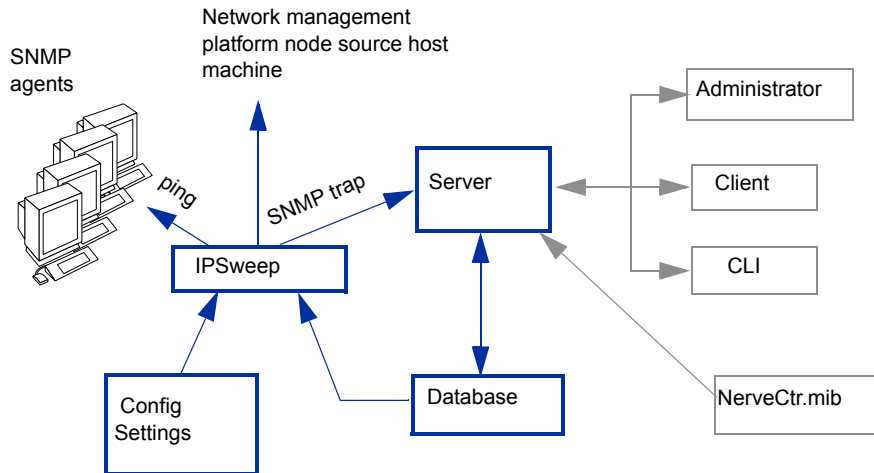

FIGURE 8-6. NerveCenter Configured to Discover Nodes

IPsweep extracts information from the NerveCenter configuration settings about the subnet IP filters defined for NerveCenter. IPSweep also obtains node information from the NerveCenter database, identifies nodes that fall within the subnet range but are not in the database, and sends those nodes a ping (ICMP echo request). If the ping returns a response, IPSweep issues an SNMP trap. The trap can be sent either to a host specified as the node source or, if no node source is specified, to the local NerveCenter. In a standalone configuration, the trap is sent to NerveCenter. Once NerveCenter receives the trap, the node is added to the NerveCenter database.

IPsweep itself does not populate the NerveCenter server database. All it does is send a trap to NerveCenter if it gets a ping response from an IP address. The server can add the “unknown” node to its database once it gets a trap.



NOTE

If you are using NerveCenter in Windows configured with Domain Name Server (DNS), the IPSweep behavior model requires that **Enable DNS for Windows Resolution** be selected. (This option is found on the WINS address tabbed page of the TCP/IP protocol, found on the Protocols tabbed page in the Network applet in the Control Panel.)

TO POPULATE THE NODE LIST USING THE IPSWEEP BEHAVIOR MODEL

1. Open NerveCenter Administrator and connect to the appropriate NerveCenter Server.
See *Connecting Administrator to a NerveCenter Server on page 44*.
2. Select the **Filters** tab and configure NerveCenter to filter by the appropriate subnet criteria.
See *Filtering Nodes by IP Address on page 105*.

**CAUTION**

If the IP Filter box is empty, the IPSweep behavior model's primary application ipsweep will not run. This precaution is to prevent NerveCenter from trying to discover all the nodes on the Internet.

3. Select the **Server** tab.

NerveCenter displays the Server tab.

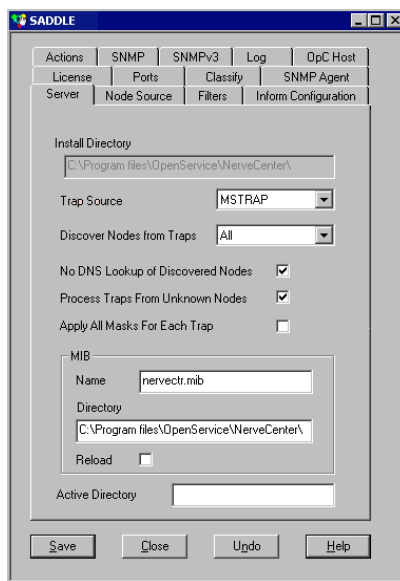

4. Select from the **Discover Nodes from Traps** list **All** or **IP Filter**.

**NOTE**

IP Filter only functions if IP Filters are enabled. See *Enabling and Disabling IP and Hostname Filters on page 111* for details.

If the **Discover Nodes from Traps** field is set to **None**, the IPSweep behavior model will not work.

5. (Optional) Select **No DNS Lookup of Discovered Nodes** to improve NerveCenter performance.
By default, No DNS Lookup of Discovered Nodes is not selected and NerveCenter performs a DNS lookup for each unknown node. If you select this box, the nodes are added by IP address and NerveCenter does not attempt a DNS lookup.
6. Select **Process Traps From Unknown Nodes**.
7. If you want NerveCenter to turn on the IPSweep behavior model every time the NerveCenter Server is started, select **Enable Discovery at Startup**.
8. From NerveCenter Client, turn on the IPSweep behavior model. See *Enabling the IPSweep Alarm in Designing and Managing Behavior Models* for details.

NerveCenter periodically runs the script ipsweep. As NerveCenter discovers unknown nodes that fall within its IP filters it will add them to the node list. For more information about NerveCenter's IPSweep behavior model, see *Using NerveCenter's IPSweep Behavior Model in Designing and Managing Behavior Models*.

Populating the Node List Manually

The two most popular methods of initially populating NerveCenter's node list are:

- ◆ *Populating Using a Network Management Platform as a Data Source on page 117*
- ◆ *Populating Using the IPSweep Behavior Model on page 119*

An alternative is to populate the NerveCenter node list by hand. For each node you want NerveCenter to manage, you must use the Node Definition window to specify the node's data, including:

- ◆ Name
- ◆ Address
- ◆ Community string
- ◆ Property group

Because defining your own node data demands a considerable amount of attention, this alternative is recommended only for the smallest number of managed nodes.

To populate NerveCenter's node list manually, follow the steps described in *Adding and Deleting Nodes Manually on page 127*.

Maintaining the Node List

To detect and correlate network events, NerveCenter must have basic information about each of the managed nodes it is monitoring.

Once you have initially populated the node list (see *Initially Populating the Node List on page 115*), NerveCenter will need a way to adapt its node list to reflect changes in your network topology. NerveCenter offers several methods for adding and deleting nodes.

These methods include:

- ◆ *Synchronization with Your Network Management Platform on page 124*
- ◆ *Adding Nodes Discovered from Traps on page 125*
- ◆ *Adding and Deleting Nodes Manually on page 127*

Table 8-4 illustrates how each method affects NerveCenter's node list.

TABLE 8-4. Maintaining NerveCenter's Node List

Method	Adds Nodes	Deletes Nodes	Changes Node Data
Resync with the platform	✓	✓	✓
Discover nodes from traps	✓		
IPSweep behavior model	✓		
Manual additions, deletions, and changes	✓	✓	✓

Synchronization with Your Network Management Platform

Over time, a network's topology will change. Eventually your network management platform will add newly discovered devices to its database. It will also delete nodes and change node information. If NerveCenter depends on your network management platform for the data in its node list, it will need to adapt to reflect these changes.

NerveCenter will automatically update its node list to keep in sync with your network management platform's node data. This occurs in the following situations:

- ◆ When your network management platform adds a node to its node database. After NerveCenter verifies the node meets the criteria set by its filters, it will add the node to its node list.
- ◆ When your network management platform deletes a node from its node database. NerveCenter will delete from its node list any node that is set to Autodelete. Autodelete is the default setting for any new node added to the node list. This setting can be changed in the node's Node Definition Window in the NerveCenter Client. (See *Discovering and Defining Nodes in Designing and Managing Behavior Models*.)
- ◆ When your network management platform changes information about a node in its node database. NerveCenter will make any necessary changes to its node data, including changes in the community string, address, parenting information or the managed/unmanaged state.



NOTE

If your network management platform unmanages a node in the NerveCenter node list, the unmanaged state will be updated in NerveCenter. However, if your network management platform unmanages a node not found in NerveCenter's node list, the node will not be added to NerveCenter.

Most often, the node list will only be updated a node at a time. Occasionally, NerveCenter will need to perform a complete resynchronization with the platform. A resynchronization gathers from the platform the most current node data for all nodes. This occurs in the following situations:

- ◆ The NerveCenter Server is started and successfully connects to the OpenView Platform Adapter (OVPA).
- ◆ A connection between the NerveCenter Server and the node source successfully reconnects after being broken.
- ◆ The NerveCenter administrator changes the way in which NerveCenter filters by capabilities or system Object Identifiers (OIDs).
- ◆ A user manually chooses **Resync** in the **Server** menu of the NerveCenter Client.

The **Machine Name** field on the **Node Source** tab of the NerveCenter Administrator specifies the name of the host running the platform resynchronizing with NerveCenter. (See [Populating Using a Network Management Platform as a Data Source on page 117](#) for more details on how to declare a node data source.)

The **Node Source** and **Filters** tabs also specify the parameters NerveCenter uses to filter node data. (See [Filtering Nodes on page 103](#).)

Anyone administering NerveCenter should be aware of two important scenarios involving changes to your network management platform's database:

- ◆ If the name changes in your network management platform's database, NerveCenter considers it to be a new node.
- ◆ If a node is unmanaged in one of your network management platform maps but is managed in another, the node will remain in the managed state in NerveCenter's node data.



CAUTION

Since your network management platform's node is matched to a NerveCenter node using its name, you should use care when changing NerveCenter's node configurations. Resynchronization adds nodes when it cannot find names that match your network management platform's map information. Therefore, if you change a node's name in the Node Definition window, resynchronization will not find a match and will add a node, resulting in two nodes with the same address but different names.

Adding Nodes Discovered from Traps

NerveCenter occasionally receives traps from nodes not included in its node list. In this situation, NerveCenter must make two decisions:

- ◆ Whether to process the trap or ignore it (as described in [Processing Traps from Unknown Nodes on page 113](#)).
- ◆ Whether to add the unknown node to its node list. This section explains how to configure this setting.

TO CONFIGURE THE WAY UNKNOWN NODES AFFECT NERVECENTER'S NODE LIST

1. Open NerveCenter Administrator and connect to the appropriate Server.
See [Connecting Administrator to a NerveCenter Server on page 44](#).

2. Select the **Server** tab.

NerveCenter displays the Server tab.

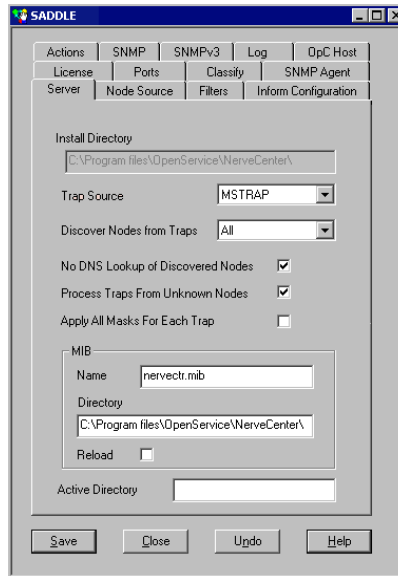

3. In the **Discover Nodes from Traps** list, select the nodes the NerveCenter should place in its node list:
 - ◆ **None** - NerveCenter will not add any unknown nodes to the node list.
 - ◆ **IP Filter** - NerveCenter will add to its node list an unknown node sending a trap *only* if it meets the criteria established by the node filters.



NOTE

IP Filter only functions if IP Filters are enabled. See [Enabling and Disabling IP and Hostname Filters on page 111](#) for details.

- ◆ With an **All** setting, NerveCenter adds to its node list any unknown node sending a trap, regardless of the node filters.
4. (Optional) Select **No DNS Lookup of Discovered Nodes** to improve NerveCenter performance.

By default, No DNS Lookup of Discovered Nodes is not selected and NerveCenter performs a DNS lookup for each unknown node. If you select this box, the nodes are added by IP address and NerveCenter does not attempt a DNS lookup.

5. Select **Save**.

Any time NerveCenter receives a trap from a node not listed in its node list, NerveCenter handles the node according to the criteria you set in the **Discover Nodes from Traps** list box.

**NOTE**

NerveCenter sets to autodelete any unknown nodes added from traps. If NerveCenter adds an unknown node discovered from a trap but your network management platform fails to add it, the node will be deleted at the next resynchronization.

Adding and Deleting Nodes Manually

Occasionally, you may want to monitor one or more nodes that do not match the parameters set by the node filters. Or you may want to delete a node or a group of nodes. NerveCenter gives you the ability to alter the node list to your own specifications.

When maintaining the node list manually, you have the following options:

- ◆ **Adding a Node Manually** — You add nodes in the NerveCenter Client module. To learn how to add a node manually, refer to *Defining Nodes Manually in Designing and Managing Behavior Models*.
- ◆ **Deleting a Node Manually** — You delete nodes in the NerveCenter Client module. To learn how to delete a node manually, refer to *Deleting Objects in Designing and Managing Behavior Models*.
- ◆ **Filter Out a Node That was Manually Deleted** — If you do not complete this step, the nodes you delete manually will be added the next time a resynchronization occurs between NerveCenter and the network management platform's database or the next time the IPSweep behavior model runs the ipsweep script. Following are instructions for filtering out a node.

TO FILTER OUT A NODE THAT WAS MANUALLY DELETED

1. Open the NerveCenter Administrator and connect to the appropriate NerveCenter Server.
2. Select the **Filters** tab.

The Filters tab is displayed.

3. In the **IP Address Filters** list, select the subnet address of the node you want to delete.
4. In the **Exclusion List** field, enter the nodes you want deleted from the node list. Separate each node with a comma, but no space; to exclude a continuous range of nodes, use a hyphen to separate the minimum and maximum number.



NOTE

If you do not complete this step, the nodes you delete will be added at the next resynchronization between NerveCenter and the network management platform's database or the next time the IPSweep behavior model runs the ipsweep script.

5. Select **Update**.
6. Select **Save**.

The nodes are permanently deleted from NerveCenter's database.

Troubleshooting: Managing node data

The following list contains some common problems users have when managing node data.

NerveCenter is not filtering a node by a capability

Problem: Filtering by capabilities is available only when a network management platform has assigned a specific capability to a node.

Solution: Have your network management platform assign a capability to the node.

See your network management platform's documentation for details.

Problem: The OVPA command line switch `-ignoreCapability` has been turned on.

Solution: From the command line, start OVPA without the `-ignoreCapability` switch.

For more details see *Integrating NerveCenter with a Network Management Platform*.

After setting an IP filter, a node that should be masked out still appears in the node list

Problem: IP filters only exclude additional nodes from being added to a node list. It does not actively delete nodes in the node list.

Solution: Either manually delete the node or force a resynchronization with your network management platform.

See *Adding and Deleting Nodes Manually on page 127* or *Synchronization with Your Network Management Platform on page 124*.

Even though I have enabled Process Traps From Unknown Nodes, NerveCenter does not update its node list when it receives a trap from an unknown node

Problem: Selecting the **Process Traps From Unknown Nodes** box does not affect NerveCenter's node list. It only tells NerveCenter to process traps.

Solution: If you want NerveCenter to update its node list based on traps received from unknown nodes, set Discover Nodes from Traps to Filter or All.

See *Adding Nodes Discovered from Traps on page 125*.

NerveCenter does not recognize my network management platform as a valid source of node data

Problem: Currently NerveCenter is able to retrieve node data from HP OpenView Network Node Manager.

Solution: Use the IPSweep behavior model to obtain node data.

See *Populating Using the IPSweep Behavior Model on page 119*.

NerveCenter is not receiving node data from my network management platform

Problem: They are using different ports.

Solution: Configure the node data source port number to be the same as the platform adapter's port.

See *Populating Using a Network Management Platform as a Data Source on page 117*.

The IPSweep behavior model will not work

Problem: Windows is configured with Domain Name Server.

Solution: Enable the **Enable DNS for Windows Resolution** feature.

See *Populating Using the IPSweep Behavior Model on page 119*.

Problem: There are no IP filters. NerveCenter will not discover nodes unless there are IP filters. This precaution is to prevent NerveCenter from trying to discover all the nodes on the Internet.

Solution: Set the appropriate IP filters.

See *Filtering Nodes by IP Address on page 105*.

Problem: The NerveCenter Server is not set to discover nodes from traps.

Solution: Set **Discover Nodes from Traps** to **All** or **Filter**.

See: *Adding Nodes Discovered from Traps on page 125*.

The NerveCenter node list contains two nodes with the same address but different names

Problem: The node name was changed. When a resynchronization occurred between NerveCenter and the network management platform, the platform added the node.

Solution: Change the name of the node in your platform, not in NerveCenter's node list.

See *Synchronization with Your Network Management Platform on page 124*.

NerveCenter deletes a node I added manually

Problem: At a resynchronization between NerveCenter and a network management platform, NerveCenter deletes any nodes marked autodelete that are not found in the platform's node database.

Solution: When you add the node disable the autodelete feature.

See *Adding and Deleting Nodes Manually on page 127*.

NerveCenter adds a node I deleted manually

Problem: At a resynchronization between NerveCenter and a network management platform or when NerveCenter runs the Discovery behavior model, NerveCenter adds any new nodes that fall within its filters.

Solution: Exclude the node in the IP filters before deleting it.

See *Filtering Nodes by IP Address on page 105*.

I'm seeing several errors recorded in the application event log window stating that ipsweep.exe is not running

Problem: Your system is looking for ipsweep.exe in the wrong directory.

Solution: Update the correct path to ipsweep.exe in the alarm action Command in the Discovery behavior model.

Problem: Ipsweep.exe is already currently running.

Solution: Kill the first process and restart the Discovery behavior model.

See *Using NerveCenter's IPSweep Behavior Model in Designing and Managing Behavior Models* for more details.

Managing SNMP Settings

This chapter contains information you need to configure NerveCenter for SNMP communication and to support SNMP v3 agents.

This chapter includes the following sections:

Section	Description
<i>Overview of NerveCenter SNMP v3 Support on page 134</i>	Summarizes NerveCenter SNMP v3 support.
<i>The Need for Node Classification on page 138</i>	Discusses node classification and the ways in which NerveCenter classifies nodes.
<i>SNMP Auto and Manual Classification Settings on page 141</i>	Describes the different types of automatic and manual classification settings you can use.
<i>Performance Tuning for Node Classification on page 146</i>	Explains how to manage SNMP performance by controlling polling frequency and intervals.
<i>Specifying SNMP Ports for NerveCenter on page 149</i>	Describes how to configure the ports NerveCenter uses to receive SNMP traps and send/receive SNMP correspondences.
<i>Discovery and Initialization of SNMP v3 Agents on page 150</i>	Summarizes the requirements for discovery and initialization of SNMP v3 agents.
<i>Configuring an SNMP v3 Agent for NerveCenter on page 151</i>	Summarizes the requirements for configuring an SNMP v3 agent for polling.
<i>Configuring an Initial User for Discovering an SNMP v3 Agent on page 154</i>	Summarizes how you configure an initial user without security restrictions so an SNMP v3 agent can be discovered.
<i>SNMP v3 Security Settings on page 155</i>	Describes how to change the authentication and privacy key passwords or the NerveCenter user and context.
<i>SNMP v3 Operations Log on page 159</i>	Describes the Operations Log that records SNMP v3 operations and errors that occur while attempting to perform those operations.
<i>SNMP Error Status on page 164</i>	Describes SNMP v3 error status messages and indicates which ones cause polling to stop for a node.
<i>SNMP Agent on page 167</i>	Describes how to configure the NerveCenter SNMP Agent.

Overview of NerveCenter SNMP v3 Support

NerveCenter support for SNMP v2c (community-based SNMP v2) and v3 includes new data types and enhanced security for communication. SNMP v1 and v2c rely on community names for authentication. SNMP v3 enhances authentication and expands its services to include privacy. SNMP v3 expands on the earlier concept of MIB views to control access to management information. SNMP v3 uses a View-based Access Control Model (VACM) to determine the level of access a user has for viewing MIB data.

Following are highlights of NerveCenter support for SNMP v2c/v3:

- ◆ Before NerveCenter can discover SNMP v3 agents on nodes, the nodes must have an initial user configured for discovery.

See [Configuring an Initial User for Discovering an SNMP v3 Agent on page 154](#).

Refer to [Confirming the SNMP Version for a Node in Designing and Managing Behavior Models](#) for details about testing communication with a node using the NerveCenter Test Version poll.

- ◆ NerveCenter communicates (sends polls) with an SNMP v3 agent on behalf of a specified NerveCenter user in a defined context. Before NerveCenter can poll SNMP v3 agents, the agents must be configured to support the NerveCenter user and context. By default, the user name is NCUser and the context is NCContext, though you can change both in NerveCenter.

See [Configuring an SNMP v3 Agent for NerveCenter on page 151](#).

See [Changing the NerveCenter SNMP v3 User Name and Context on page 157](#).

- ◆ NerveCenter supports three security levels for communicating with SNMP v3 agents. By default, NerveCenter sets the security level to noAuthNoPriv, which means the v3 agent sends and receives messages without authentication or encryption.

See [NerveCenter Support for SNMP v3 Security on page 136](#) for details about security.

Refer to [Changing the Security Level of an SNMP v3 Node in Designing and Managing Behavior Models](#) for details about setting a node's security level.

- ◆ The authentication and privacy protocols require specialized keys, called authentication and privacy keys. These keys are generated from corresponding passwords. You can change these passwords in NerveCenter, thereby changing the keys. When changing keys in NerveCenter, you can command NerveCenter to update the key changes on all nodes.

See [NerveCenter Support for SNMP v3 Digest Keys and Passwords on page 137](#).

See [Changing the SNMP v3 Key Passwords on page 155](#).

- ◆ NerveCenter supports either HMAC-MD5-96 (MD5) or HMAC-SHA-96 (SHA) as authentication protocol on a per-node basis and CBC-DES as the privacy protocol. The default authentication protocol for NerveCenter is MD5. If you change the authentication protocol on an SNMP v3 agent, you must likewise change the protocol used by NerveCenter to manage the corresponding node in its database.

Refer to *Changing the Authentication Protocol for an SNMP v3 Node in Designing and Managing Behavior Models* for details about changing the authentication protocol used by NerveCenter for an agent.

- ◆ A node must have SNMP version information before NerveCenter can poll the node or process a trap from the node. NerveCenter can discover the version of a node automatically or manually. If auto-classification is enabled, then a newly added node (discovered from a trap, added from a platform such as HP OpenView, imported from another NerveCenter) will be classified at the highest level possible.



NOTE

Auto-classification is disabled when you install NerveCenter. You must enable this feature before NerveCenter can classify nodes added to its database.

See *SNMP Auto and Manual Classification Settings on page 141*.

Refer to *Classifying the SNMP Version Configured on Nodes in Designing and Managing Behavior Models* for details about classifying nodes manually.

- ◆ The trap source specified during installation can be changed to MSTrap, OVTrapD or NerveCenter. Changing the trap source requires stopping and starting the related applications (e.g., OVTrapD) and restarting the NerveCenter Server.

See *Managing the NerveCenter Trap Source on page 54*.

- ◆ SNMP v3 operations are logged to a file so that you can follow the progress of v3 activities. The log includes information about activities (e.g., a key change initiated by the user) as well as errors that occur while NerveCenter attempts to perform the activities.

See *SNMP v3 Operations Log on page 159*.

See *SNMP Error Status on page 164* for information about SNMP v3 errors.

- ◆ NerveCenter ships with behavior models that provide the status of various applications monitored by the SNMP Research CIAgent.

For complete details about these and all behavior models, refer to the *Behavior Models Cookbook*.

NerveCenter Support for SNMP v3 Security

SNMP v3 specifications enable any two devices to communicate in a completely secure fashion using message authentication to validate users and encryption to ensure the secrecy of the communication. SNMP v3 provides a User-based Security Model (USM) to establish authentication and secrecy.

NerveCenter supports three security levels for communicating with an SNMP v3 agent:

- ◆ **NoAuth/NoPriv:** Passwords for authorization and privacy are not required to communicate with the agent. NerveCenter still requires the user name and context for polling.
- ◆ **Auth/NoPriv:** The authorization protocol and password are required to communicate with the agent. NerveCenter requires the user name, context, and authentication password for polling.
- ◆ **Auth/Priv:** All security parameters are required to communicate with the agent. NerveCenter requires the user name, context, and the privacy and authentication passwords for polling.

Communication between any two SNMP v3 entities takes place on behalf of a uniquely identified user within the management domain. The security level used for this communication defines the kind of security services—message authentication and encryption—used while exchanging data. NerveCenter communicates with SNMP v3 nodes on behalf of the NerveCenter poll user in the poll context. By default, the user name is NCUser and the context is NCContext, though you can change both in NerveCenter.

If you do not specify a security level for an SNMP v3 node, NerveCenter uses a default security level of NoAuthNoPriv, which means that message authentication and encryption services are not used for data exchange with the node. You can later change the security level in NerveCenter.



NOTE

The NerveCenter poll user, context, authentication password, and privacy password can be changed in NerveCenter Administrator. If you change the passwords, you can update this information on all nodes directly from the NerveCenter Administrator.

The security level used by NerveCenter while polling SNMP v3 nodes is configured for each node in NerveCenter Client. Information specific to nodes, such as version, security level, and authentication protocol, are entered in NerveCenter Client for the node.

NerveCenter Support for SNMP v3 Digest Keys and Passwords

SNMPv3 protocols allow any two devices to communicate in a completely secure fashion using message authentication and message encryption to ensure the secrecy of the communication. In any SNMP v3 communication, one of the two communicating entities plays a role of authoritative entity for the communication, and communication is performed on behalf of a unique user within the management domain.

The sender of a secure message attaches a code, called a digest, for authentication and encrypts the message to ensure privacy. To generate this digest, the sender uses an authentication key at the authoritative entity of the user on whose behalf communication takes place. Similarly, to encrypt a message, the sender uses a privacy key at the authoritative entity of the user on whose behalf communication takes place. These keys are generated from the authentication password and privacy password, respectively, for the user.

SNMP v3 specifications have defined a localized key-generation scheme. For every user, the authentication key at every SNMP v3 entity is a function of the `snmpEngineID` of that entity, the user's authentication password, and the authentication protocol. For every user, the privacy key at every SNMP v3 entity is a function of the `snmpEngineID` of that entity, the user's privacy password, and the privacy protocol. NerveCenter supports this localized key-generation scheme.

NerveCenter communicates with SNMP v3 nodes on behalf of the NerveCenter poll user (by default, `NCUser` for MD5 authentication and `NCUserSHA1` for SHA-1 authentication) in the poll context (`NCContext` by default). NerveCenter needs to know the authentication and privacy passwords for this user in order to generate the keys required for secure communication. Whenever NerveCenter learns the `snmpEngineID` of a newly discovered SNMP v3 agent with a security level other than `NoAuthNoPriv`, NerveCenter generates these keys for the NerveCenter poll user on that agent. By default, the passwords are `NCUserAuthPwd` (authentication) and `NCUserPrivPwd` (privacy), though you can change both in NerveCenter Administrator. These passwords are used for all nodes that NerveCenter manages.

When the message is sent, if authentication is required (a security level of `AuthNoPriv` is specified for the node), the sender uses the authentication key to generate the digest for the message. This digest is appended to the message.

If encryption is required (a security level of `AuthPriv` is specified for the node), the sender uses the privacy key to generate the digest for the message. For this security level, only the privacy digest is required; privacy assumes authentication, and you cannot have encryption without authentication.

On receipt of a secure message, a receiver does the following:

- ◆ Separates the message from the digest (authentication or privacy).
- ◆ Uses the corresponding key available in its local store to generate its local copy of the digest from the message.

- ◆ Compares the two digests (i.e. one received in the message and one generated locally). If both digests are the same, the recipient authenticates or decrypts the message using the corresponding local key. If the digests are not the same (indicating a lack of authentication), the recipient discards the message.
- ◆ The recipient reads and processes the message.

The Need for Node Classification

Every SNMP agent residing on a network device is represented by a corresponding node object in NerveCenter database. Attributes of the agent, such as IP address, port number, SNMP version, and other attributes known to NerveCenter, are stored as properties of the corresponding node object in NerveCenter database. Whenever NerveCenter needs to communicate with any SNMP agent it monitors, it uses the required attributes from the corresponding node object in its database. When communicating with any SNMP agent, NerveCenter constructs an SNMP version-specific message based on the node's version information available in the NerveCenter database. Similarly, when receiving a message from a known agent, NerveCenter uses the version information available in the corresponding node object in its database to decide whether to process the message. To communicate with the agent on a managed device, NerveCenter must use the same SNMP version configured at the agent.

Many SNMP agent implementations available in the market support multiple versions of SNMP. Today's more complex enterprise networks are expected to have agents from multiple vendors supporting varied combinations of SNMP versions. A sophisticated network management product like NerveCenter, therefore, must provide a way to specify the SNMP version to be used when communicating with each of these agents. In very large networks, specifying this version information manually for each device quickly becomes an unmanageable task.

NerveCenter can classify nodes automatically based on SNMP version implementation on the corresponding agent, or you can manually classify nodes on a case-by-case basis. Finally, NerveCenter lets you specify the SNMP version to use when NerveCenter communicates with the SNMP agent.

NerveCenterNode Classification Algorithm

The NerveCenter node classification algorithm is depicted in *Figure 9-1*:

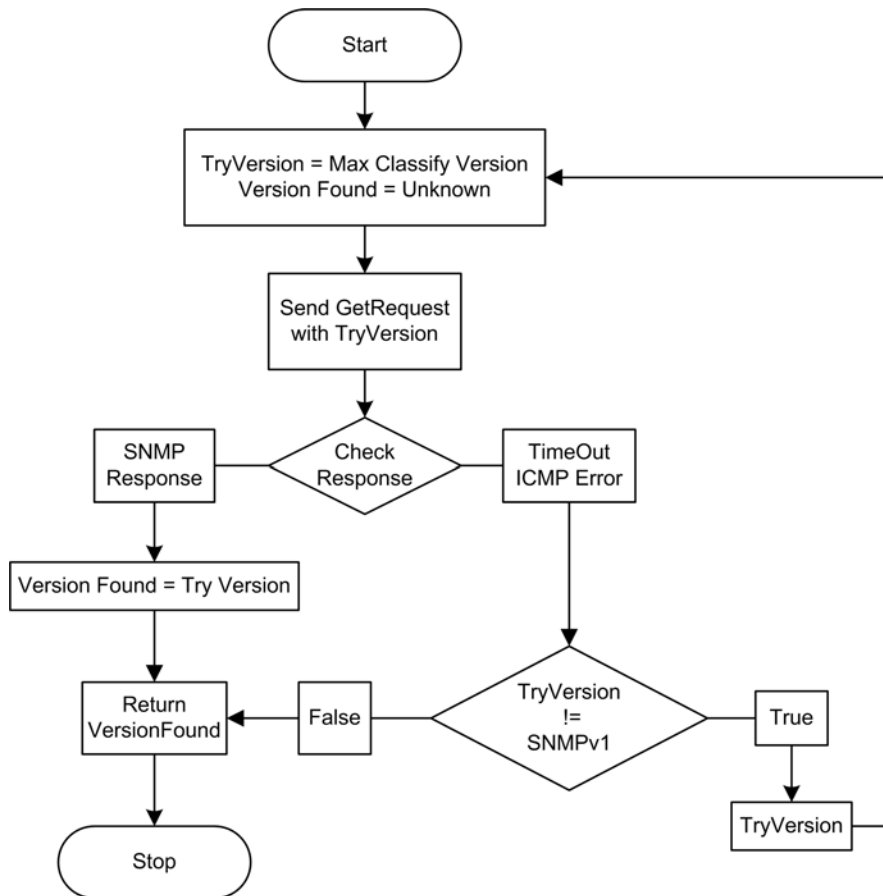

FIGURE 9-1. NerveCenter Node Classification Algorithm

How NerveCenter Classifies a Node

NerveCenter tries to classify a node based on the highest version of SNMP implemented on the corresponding SNMP agent. You can, however, limit the highest version NerveCenter attempts to classify by specifying a maximum classification version in the NerveCenter Administrator. When you specify a maximum classification version, NerveCenter never attempts to classify a node above the version you specified.

When classifying a node, you need to know whether a particular version is supported on the corresponding agent, NerveCenter sends an SNMP GetRequest message and listens for the response. Receipt of an SNMP response or SNMP error indicates that the particular version is supported on the corresponding agent. If NerveCenter receives a response other than an SNMP reply, NerveCenter concludes that the particular version is not supported on the agent. To ascertain support for SNMP v1 and SNMP v2c, NerveCenter sends a GetRequest message for SysObjectID with a read community of public.

To ascertain SNMP v3 agents, NerveCenter sends the GetRequest message to discover the snmpEngineID at the agent on behalf of the ‘initial’ user, as specified in the suggested engine discovery mechanism in RFC 2574.



NOTE

Whenever NerveCenter ascertains that an agent supports SNMP v3, NerveCenter also assigns a default security level for communication with the node as **NoAuthNoPriv**. Please refer to NerveCenter online help for details about changing a node’s default security level or configuring an initial user on SNMP v3 agents.

Irrespective of the SNMP version of the node, NerveCenter always tries to ascertain the node’s SNMP version with the “Maximum Classification Version” specified.

If NerveCenter does not get SNMP responses or SNMP errors to its GetRequest messages, then NerveCenter designates such nodes as ‘unknown’. For details of the algorithm NerveCenter uses to classify nodes, see [NerveCenterNode Classification Algorithm on page 139](#).

You can also test a particular version specified on a node. In the NerveCenter Client, select the node from the node list view and selecting Test Version from the right mouse click menu. This Test Version is similar to the GetRequest discussed above. If the agent does not support the version specified on the node, you get a test version failed error message.

SNMP Auto and Manual Classification Settings

Using manual or auto-classification, NerveCenter can send requests to determine the highest SNMP version on a node. When you enable auto-classification, NerveCenter attempts to classify each node automatically when the node is added to the NerveCenter database.

A node must have correct version information, either supplied manually by the user or obtained via classification, before NerveCenter can poll the node or process a trap from the node.

More information is contained in the following sections:

- ◆ [How NerveCenter Classifies a Node's SNMP Version on page 141](#)
- ◆ [When NerveCenter Classifies a Node's SNMP Version on page 142](#)
- ◆ [Classifying Nodes Automatically on page 143](#)
- ◆ [Setting a Maximum Classify Value on page 145](#)

How NerveCenter Classifies a Node's SNMP Version

There are two main ways that NerveCenter classifies nodes:

- ◆ **Manually** — You can issue a classify command in NerveCenter Client to classify one, several, or all nodes in the database. Procedures for issuing such commands are described in [Manually Changing the SNMP Version Used to Manage a Node in Designing and Managing Behavior Models](#).
- ◆ **Automatically** — NerveCenter can be configured to classify nodes when they are added to its database (discovered from a trap, added from a platform such as OpenView Network Node Manager, or imported from another NerveCenter).

Each time NerveCenter attempts to classify a node, NerveCenter sends a series of classification requests (GetRequest messages) to the node. NerveCenter classifies the node based on the responses to these requests. Each request corresponds to an SNMP version—either v1, v2c, or v3.

While classifying a node, NerveCenter attempts to detect the maximum supported version on the agent up to a maximum specified version, which you can configure in NerveCenter Administrator. So, for example, if you set a maximum classification version of v2c, NerveCenter never attempts to classify nodes any higher than v2c. (However, in the Client module, you can manually specify any version for a node and then test communication with the agent using that version.)

Based on the response to its messages, NerveCenter changes its SNMP version setting for the node.

**CAUTION**

Note the following about node classification:

- When NerveCenter attempts to classify a node, its node version information is lost. For example, if a node was previously identified as SNMP v3 and is changed (to v1, v2c, or Unknown), then v3-related security information for the node is lost.
 - If NerveCenter fails to classify the node, then the version of the node is set to “Unknown.” NerveCenter cannot poll a node with an unknown version.
 - A node must have correct version information, either supplied manually or via classification, before NerveCenter can poll or process a trap from the node.
-

When NerveCenter Classifies a Node’s SNMP Version

There are two main ways that NerveCenter classifies nodes:

- On demand—You can issue a classify command in NerveCenter Client to classify one, several, or all nodes in the database. Procedures for issuing such commands are described in *Configuring SNMP Settings for Nodes in Designing and Managing Behavior Models*.
- Automatically—You can set up auto-classification in NerveCenter Administrator. When NerveCenter adds nodes to its database (discovered from a trap, added from a platform such as OpenView Network Node Manager, or imported from another NerveCenter), any nodes without version information are classified at the highest possible level. NerveCenter does not attempt auto-classification for nodes that you add manually in Client.

When you enable auto-classification, NerveCenter attempts it in the following instances:

- A node is added through a node file from importutil or from the Client, and the node does not have a version or has the version “Unknown.” This would happen, for example, if you were importing the node from a previous version of NerveCenter.
- A node is imported from a NerveCenter Server without a version or with version Unknown.
- A node is added from a trap, and the node’s version is not v3. NerveCenter verifies whether these nodes are v1 or v2. If the trap is v3, NerveCenter does not need further verification.
- NerveCenter is co-resident with a network management platform that sends nodes to NerveCenter. All nodes added from OpenView Network Node Manager are v1 by default.

**NOTE**

NerveCenter does not attempt to auto-classify nodes that you add manually.

Disabling auto-classification in Administrator prevents auto-classification. If you choose to disable auto-classification, NerveCenter does not poll nodes whose SNMP version is unknown. (You can still classify nodes manually in NerveCenter Client with the available commands.)

Classifying Nodes Automatically

In addition to manually adding and classifying nodes, NerveCenter can automatically detect agents on network devices it monitors and add the corresponding node objects for these automatically detected agents. Moreover, NerveCenter can be configured to recognize agents residing on network devices from other network management platforms like OpenView, another NerveCenter, and so on. In such circumstances, if the version information is not available about these automatically detected agents, NerveCenter assigns the version information to corresponding node objects as 'unknown'. Since NerveCenter does not poll nodes having 'unknown' version, its default behavior is to automatically classify these automatically detected agents.

When NerveCenter's autotclassification feature is enabled, NerveCenter attempts to autotclassify a node in the following situations:

- ◆ When nodes are imported via a node file (using ImportUtil or NerveCenter Client), and a node has no SNMP version information or the SNMP version is 'unknown'. (Such a scenario might occur if you were importing nodes from a previous version of NerveCenter.)
- ◆ When nodes are imported from another NerveCenter Server, and a node has no SNMP version or the SNMP version of the node is 'unknown'.
- ◆ When a new node is added to the NerveCenter database because a trap was received from a corresponding agent or source previously unknown to NerveCenter.
- ◆ When NerveCenter is co-resident with OpenView Network Node Manager and OpenView sends nodes to NerveCenter. In this case, NerveCenter does not know the SNMP version of the newly added node from OpenView.



NOTE

When NerveCenter receives SNMP v3 traps from unknown agents with an AuthNoPriv or an AuthPriv security level, then NerveCenter processes these traps on behalf of the poll user and in the poll context configured in NerveCenter. (See NerveCenter online help for more information.) When autotclassification is enabled, NerveCenter attempts to classify these unknown nodes up to the 'maximum classification version' specified by the user.

Follow the steps below to enable/disable the node auto-classification feature in the NerveCenter Administrator.

TO ENABLE OR DISABLE NODE AUTO-CLASSIFICATION**NOTE**

When auto-classification is disabled, then NerveCenter sets the nodes discovered by OpenView as SNMP v1.

1. In the NerveCenter Administrator, select the **Classify** tab.
2. To enable auto-classification, check the **Auto Classify** checkbox.

NerveCenter auto-classification is enabled for whichever version you select, but NerveCenter never attempts to auto-classify a node for any version above your selection. For example, if you select v2, NerveCenter can send classification requests only for v1 and v2.

3. To disable auto-classification, uncheck the **Auto Classify** checkbox.

**NOTE**

If you disable auto-classification, bear in mind that NerveCenter does not poll nodes whose SNMP version is unknown.

4. Select the **Save** button.
-

Setting a Maximum Classify Value

Whether using auto-classification or manual node classification (in Client), you specify the highest version you want NerveCenter to detect. When performing classification, NerveCenter will never attempt to classify a node for any version above the version you specify. For example, if you select v2c, NerveCenter can send classification requests only for SNMP v1 and v2c. (However, in the Client module, you can manually specify any version for a node and then test communication with the agent using that version.)

TO SET A MAXIMUM CLASSIFY VALUE

1. Open NerveCenter Administrator and connect to the appropriate NerveCenter Server. See [Connecting Administrator to a NerveCenter Server on page 44](#).
2. Select the **Classify** tab.

The **Classify** tab is displayed.

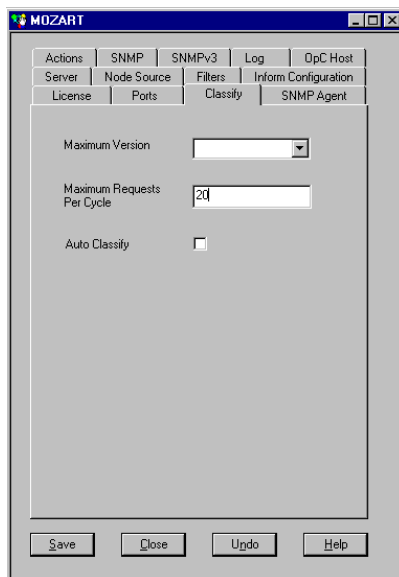

3. Select the highest level you want to classify from the **Maximum Version** drop-down listbox.
4. Select **Save**.

Performance Tuning for Node Classification

SNMP v3-specific operations for large numbers of nodes can cause bursts of traffic on the network. To help you to control this type of sudden SNMP v3-related rise of traffic on the network, you can set the number of requests per cycle and the poll interval.

Setting the Maximum SNMP v3 Requests per Cycle

You control SNMP v3 performance by setting a maximum number of requests per processing cycle (approximately one second) for all v3 operations including classification, SNMP test version poll, version change, authentication protocol change, security level change, and initialization requests. Consider the number of SNMP messages per second your network devices can handle, and whether messaging uses authentication and privacy keys, which further slows performance.

TO SET THE MAXIMUM NUMBER OF SNMP v3 REQUESTS

1. Open NerveCenter Administrator and connect to the appropriate NerveCenter Server.
2. Select the **Classify** tab.

The **Classify** tab is displayed.

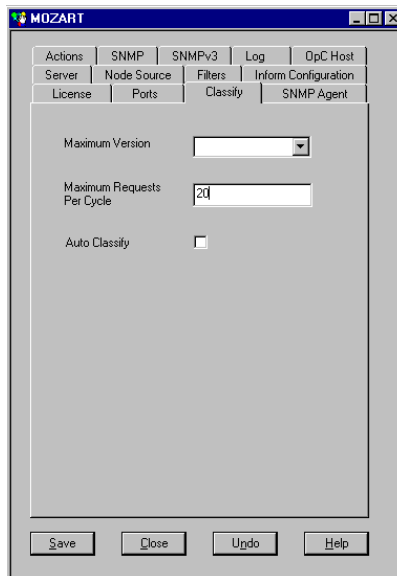

3. In the **Maximum Requests Per Cycle** field, enter the maximum number of SNMP v3 requests you want NerveCenter to process. The default value is 20.
 4. Select **Save**.
-

NerveCenter will handle SNMP data according to these settings.

Specifying SNMP Poll Intervals for NerveCenter

You can change the interval (three attempts by default) at which NerveCenter sends polls to SNMP agents to obtain MIB information. For example, NerveCenter would make four polling attempts to a device that could not respond, the initial attempt and three retries.

The retry interval is significant in that the rate should be high enough to account for the number of retries per interval. For example, if a NerveCenter Server is set to retry three times at a 30 second interval, the polling rate for any of its behavior model's polls should be no lower than 90 seconds.

TO SPECIFY NERVECENTER POLL SETTINGS

1. Open NerveCenter Administrator and connect to the appropriate NerveCenter Server.
2. Select the **SNMP** tab.

The SNMP tab is displayed.

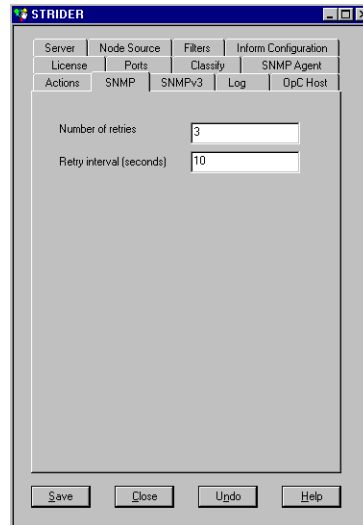

3. In the **Number of retries** field, enter the number of times to reissue unanswered SNMP or ICMP request polls.
4. In the **Retry interval** field, enter the number of seconds NerveCenter should wait for a reply to a poll before issuing another.
5. Select **Save**.

NerveCenter will handle SNMP data according to these settings.

Specifying SNMP Ports for NerveCenter

NerveCenter has two primary sources of information about network conditions:

- ◆ NerveCenter listens passively for SNMP traps sent by a managed device.
- ◆ NerveCenter actively polls the SNMP agents on a managed device.

You can change the ports that NerveCenter uses for receiving traps and sending polls.

TO SPECIFY SNMP PORT SETTINGS FOR NERVECENTER

1. Open NerveCenter Administrator and connect to the appropriate NerveCenter Server. See [Connecting Administrator to a NerveCenter Server on page 44](#).

2. Select the **Ports** tab.

The Ports tab is displayed.

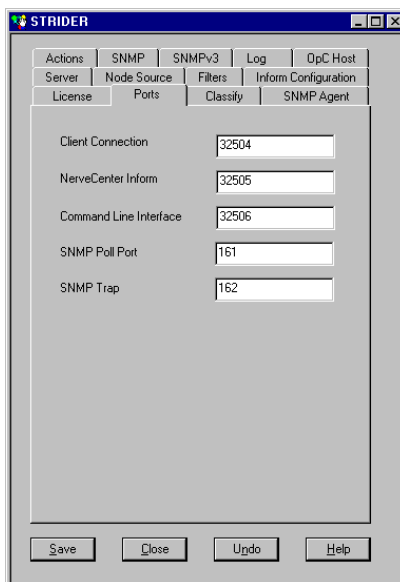

3. In the **SNMP Poll** field, enter the number of the port you want NerveCenter to use to communicate with SNMP agents. This port is used to get or set SNMP information.

The value entered here specifies the port on the node to which NerveCenter sends SNMP polls. You can change the port for any particular node in the node's definition window in NerveCenter Client. It is suggested that you keep the default port number 161.

4. In the **SNMP Trap** field, enter the port number that you want NerveCenter to use for receiving SNMP traps. This setting has no effect if NerveCenter is co-resident with HP OpenView Network Node Manager. OpenView has the trap port and an internal process enables NerveCenter to receive a copy of the trap. The default port number is 162.

**NOTE**

You must shut down and restart the NerveCenter Server before the SNMP Trap port change takes effect.

To capture SNMP v3 traps, the SNMP Trap port must be free traps. This requires you to shut down both the MS Trap service and OVTrapD if they are running.

5. Select **Save**.

NerveCenter will handle SNMP data according to these settings.

Discovery and Initialization of SNMP v3 Agents

NerveCenter can discover and monitor nodes with SNMP v1 and v2 agents without knowing anything in particular about the agent beforehand. For nodes with SNMP v3 agents, however, NerveCenter requires certain information before the node can be discovered and managed. The process of obtaining this information is call initialization.

Initialization occurs in two cases:

- ◆ After installation, a node must be initialized for NerveCenter to obtain engine information required for polling.
- ◆ When a node's version is changed to SNMP v3 from some other version, the node must be initialized.

Before NerveCenter can initialize a node, the SNMP v3 agent must be configured on the node with the poll user, poll context and security level.

- ◆ See SNMP v3 security for information about the poll user, poll context, and security level.
- ◆ See *Configuring an SNMP v3 Agent for NerveCenter on page 151* for configuration details.

Initialization consists of the following:

- ◆ Obtaining the `snmpEngineID` value for the agent. To obtain this information, the agent must be configured with an “initial” user that has a security level of `NoAuthNoPriv`. See [Configuring an Initial User for Discovering an SNMP v3 Agent on page 154](#) for details.

The engine ID is all that’s required for discovering an SNMP v3 node.

- ◆ Obtaining additional engine information if required for the chosen level of security.

NerveCenter requires additional engine information when the NerveCenter user has a security level other than `NoAuthNoPriv`. In this case, NerveCenter must obtain both the `snmpEngineBoots` and `snmpEngineTime` values of the SNMP v3 agent. NerveCenter must know the engine ID before it can request the boots and time information from the agent.



NOTE

SNMPv3 specifications makes a provision for allowing completely secure initial configuration of agents wherein an agent need not disclose its `snmpEngineID`. Network management applications must obtain on their own the `snmpEngineID` of such agents. NerveCenter cannot initialize or poll such agents.

Configuring an SNMP v3 Agent for NerveCenter

Before NerveCenter can discover or poll an SNMP v3 agent on a node, the following information must be configured on the SNMP v3 agent:

- ◆ NerveCenter user (also referred to as poll user)
- ◆ NerveCenter context (also referred to as poll context)

NerveCenter then polls the SNMP v3 agent on behalf of the poll user in this context. In addition to the poll user and context, the following parameters must be configured on the SNMP v3 agent.



NOTE

The following descriptions serve only as guidelines for configuring SNMP v3 agents for NerveCenter. For exact procedural details about configuring SNMP v3 agents, consult the user documentation supplied by your SNMP v3 agent provider.

- ◆ **User Name (MD5):** (`usmUserName`) NerveCenter communicates with the SNMP v3 agents using MD5 authentication on behalf of the user name you provide. By default the MD5 authentication user name is `NCUser`. The user name must be configured on all SNMP v3 agents using MD5 authentication with whom NerveCenter communicates. If you specify a

different name for this user on the agent, then you must configure this new user name on all the SNMP v3 agents using MD5 authentication managed by NerveCenter. Moreover you must change the name accordingly in NerveCenter Administrator. The MD5 authentication user name and the SHA-1 authentication user name must be different.

- ◆ **User Name (SHA-1):** (usmUserName) NerveCenter communicates with the SNMP v3 agents using SHA-1 authentication on behalf of the user name you provide. By default the SHA-1 authentication user name is NCUserSHA1. The user name must be configured on all SNMP v3 agents using SHA-1 authentication with whom NerveCenter communicates. If you specify a different name for this user on the agent, then you must configure this new user name on all the SNMP v3 agents using SHA-1 authentication managed by NerveCenter. Moreover you must change the name accordingly in NerveCenter Administrator. The MD5 authentication user name and the SHA-1 authentication user name must be different.
- ◆ **User Context:** (vacmContextName) User context in which NerveCenter communicates with the SNMP v3 agent. NerveCenter uses only one user context for communicating with all SNMP v3 agents, which by default is NCContext. NCContext must be configured on all SNMP v3 agents with whom NerveCenter communicates. If you specify a different context name on the agent, then you must configure this new user context on all the SNMP v3 agents managed by NerveCenter. Moreover you must change the name accordingly in NerveCenter Administrator.

When determining the context permissions for the NerveCenter user, make sure the user can access all the MIBs that you want NerveCenter to manage. That means the NerveCenter user/context should have access to all the MIB objects that you want NerveCenter to manage, given the security level you choose for the agent.

- ◆ **Security level:** (SecurityLevel) Security level NerveCenter uses to communicate with the SNMP v3 agent. NerveCenter supports all three security levels specified by SNMP v3: authPriv, noAuthNoPriv, and authNoPriv. If you later change the security level for the agent on the node, you must also change this information for the node in NerveCenter Client.

Make sure to specify the appropriate level of security for the information NerveCenter manages. If you specify noAuthNoPriv, you will not have authentication or encryption for your SNMP v3 messages.

- ◆ **Authentication Protocol:** (usmUserAuthProtocol) At present SNMP v3 specifications define two message authentication schemes: HMAC-MD5-96 (MD5) and HMAC-SHA-96 (SHA). You can choose either of these two protocols for the agent, but you must specify the protocol you choose in NerveCenter Client for the respective node. By default, NerveCenter specifies MD5 for all nodes. If you choose to configure the agent with SHA instead, then you must change this information for the node in NerveCenter Client. The key localization scheme defined in SNMP v3 specifications has a link with the authentication protocol. Therefore, whenever you change the authentication protocol, NerveCenter must recompute the keys for

the agent concerned. If you are using `noAuthNoPriv` security level, then configure the SNMP v3 agent with `usmNoAuthProtocol` to be used for communication. Of course, then you will not have either authentication or encryption for your SNMP v3 messages.

- ◆ **Privacy Protocol:** (`usmUserPrivProtocol`) SNMP v3 standard specifies that CBC-DES can be used for encryption services, and that is the only protocol NerveCenter supports. If you want encryption services, then configure the SNMP v3 agent to use CBC-DES as its privacy protocol to communicate on behalf of NerveCenter user in context with the `AuthPriv` security level. If you are using `noAuthNoPriv` or `AuthNoPriv` security levels, then you can configure the SNMP v3 agent with `usmNoPrivProtocol`. Of course, then you will not have encryption for your SNMP v3 messages. If you use some protocol other than CBC-DES, NerveCenter can not use encryption services to manage the agent.
- ◆ **Passwords:** (`AuthKey`, `PrivKey`) Configuring the NerveCenter user also involves configuring the authentication and privacy passwords. The passwords you provide are converted to authentication keys at runtime.

NerveCenter uses the following as default passwords for the NerveCenter user:

- ◆ `NCUserAuthPwd` (for the authentication password)
- ◆ `NCUserPrivPwd` (for the privacy password)

If you choose a security level of `authPriv` for a node, both passwords are used. For a security level of `authNoPriv`, only the authentication password is used. For a security level of `noAuthNoPriv`, no passwords are used. Depending on the security level you set up for the agent, you must configure the NerveCenter user with these same passwords:

These passwords, along with `snmpEngineID` and the authentication protocol (MD5 or SHA) are used to generate keys (`AuthKey` and `PrivKey` respectively). Refer to the SNMP v3 specifications for more information. If you choose different authentication and privacy passwords in NerveCenter, then configure all SNMP v3 agents managed by NerveCenter to use the authentication and privacy passwords designated for the NerveCenter user. If you change the passwords on one agent, you must make the change on all SNMP v3 agents managed by NerveCenter.

Initially you need to configure these passwords directly on all SNMP v3 agents that you want NerveCenter to manage. If you later change the passwords, you can do so from the NerveCenter Administrator.

Configuring an Initial User for Discovering an SNMP v3 Agent

To discover an SNMP v3 node, NerveCenter sends a GetRequest message to that node with the following parameters:

- ◆ SecurityLevel: set to (noAuthNoPriv)
- ◆ MsgUserName: set to (initial)
- ◆ MsgAuthoritativeEngineID: set to zerolength (‘ ‘)
- ◆ Empty variable bindings (variable-bindings=‘ ‘)



NOTE

For exact procedural details about configuring SNMP v3 agents, consult the user documentation supplied by your SNMP v3 agent provider.

Properly configured SNMP v3 agents respond to GetRequest with a Report PDU, which includes its local snmpEngineID (supplied within the msgAuthoritativeEngineID field). After NerveCenter obtains the snmpEngineID, NerveCenter can discover the node as an SNMP v3 agent.

This process of discovering SNMP v3 agents is recommended in SNMP v3 specifications. Most SNMP v3 agents are preconfigured with an “initial” user and respond to the GetRequest as described, so your agent generally won’t require any special type of configuration. Refer to the user documentation supplied by your SNMP v3 agent provider for detailed information.

NerveCenter can communicate with devices that support any available version of SNMP: v1, v2c, and v3. All SNMP agents and network devices managed by NerveCenter are represented as nodes in the database. NerveCenter must which version of SNMP to use when communicating with these agents; NerveCenter uses the SNMP version assigned to the node object in the database. Whenever a node is added to NerveCenter database, the node should have an SNMP version associated with it. Such SNMP version information can be assigned manually or automatically.

SNMP v3 Security Settings

Before NerveCenter can poll SNMP v3 agents, the agents must be configured to support a NerveCenter user. By default the user name is NCUser, though you can change the name in NerveCenter Administrator.

The NerveCenter user (NCUser) shall have a context (NCContext by default) and two passwords (authentication and privacy). You must supply the authentication and privacy passwords for the NerveCenter user configured on your devices. The security level and authentication protocol are set at the node level in NerveCenter Client.

More information is contained in the following sections:

- ◆ *Changing the SNMP v3 Key Passwords on page 155*
- ◆ *Changing the NerveCenter SNMP v3 User Name and Context on page 157*

Changing the SNMP v3 Key Passwords

The authentication and privacy protocols require specialized keys, called authentication and privacy keys. These keys are generated from corresponding passwords. Before NerveCenter can poll SNMP v3 nodes, NerveCenter requires passwords for the NerveCenter user (NCUser) configured on your v3 agents.

By default, these passwords are as follows when you install NerveCenter.

- ◆ The default authentication password is NCUserAuthPwd. This password is required for AuthNoPriv and AuthPriv security.
- ◆ The default privacy password is NCUserPrivPwd. This password is required for AuthPriv security.

After installation, you can change the passwords as appropriate for your network management strategy. Optionally, you can command NerveCenter to update the new passwords on all managed nodes.

**NOTE**

Each password must have at least eight characters, with a maximum length of 32 characters. The passwords are case sensitive.

TO PROVIDE OR CHANGE SNMP V3 PASSWORDS

1. Open NerveCenter Administrator and connect to the appropriate NerveCenter Server.
2. Select the **SNMPv3** tab.

The SNMPv3 tab is displayed.

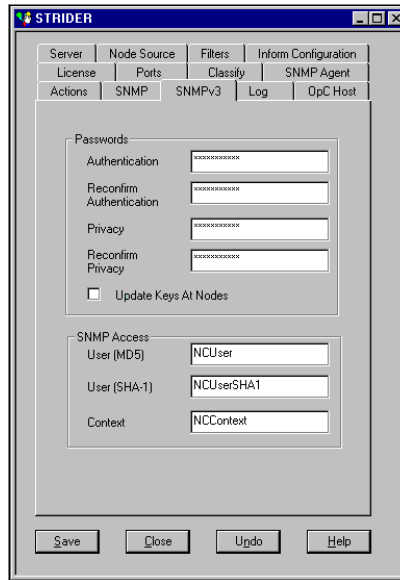

3. Enter your authentication password in the **Authentication** field and retype it in the **Reconfirm Authentication** field.
4. Enter your privacy password in the **Privacy** field.
5. Retype this password in the **Reconfirm Privacy** field.
6. To update the passwords on all managed agents, select **Update Keys At Nodes**.

Normally, you want NerveCenter to update agent passwords. If you prefer to do this manually or if you have already set the passwords on each agent, do not select the checkbox.

7. Select **Save**.

A message box displays a warning that NerveCenter must stop polling SNMP v3 nodes while performing this operation.

8. Select **Yes** to save the new passwords or **No** to cancel the change.

When NerveCenter updates passwords on managed agents, all polling of SNMP v3 nodes is paused until the operation is complete. In addition, various v3 operations (e.g., change of authentication protocol or security level) are not available in NerveCenter Client during this operation.

After the key change, NerveCenter is configured with the new passwords even if the key change fails on an agent. Key change failure is indicated in the node's properties in NerveCenter Client. If NerveCenter Server is stopped during a remote key change operation, the operation resumes automatically when the Server is restarted.

Changing the NerveCenter SNMP v3 User Name and Context

Before NerveCenter can poll SNMP v3 agents, they must be configured to support a user and context. By default the MD5 user name is NCUser, the SHA-1 user name is NCUserSHA1, and the context is NCContext. If you change these values on your agents, you must make the same change in NerveCenter Administrator. You should change user names and context on a regular basis to ensure privacy, or if you have multiple NerveCenter managing different categories of devices, you may want different user names and contexts associated with each category.

TO CHANGE THE USER NAME OR CONTEXT

1. Open NerveCenter Administrator and connect to the appropriate NerveCenter Server. See [Connecting Administrator to a NerveCenter Server on page 44](#).
2. Select the **SNMPv3** tab.

The SNMPv3 tab is displayed.

3. Enter enter the new MD5 user name in the **User (MD5)** field. Select the existing text and type the name you want.
4. Enter enter the new SHA-1 user name in the **User (SHA-1)** field. Select the existing text and type the name you want.



CAUTION

The MD5 authentication user name and the SHA-1 authentication user name must be different.

5. Enter the new context in the **Context** field.
6. Select **Save**.

NerveCenter is configured with the new user name and context and will use these names when communicating with managed nodes.

SNMP v3 Operations Log

Whenever a NerveCenter Server receives a request for an SNMP v3 operation (e.g. authorization or privacy key change request) or an error occurs while attempting to perform an SNMP v3 operation (e.g. v3 initialization fails), the NerveCenter Server logs a message to a file. This log file, named `v3messages.log`, resides in the NerveCenter installation log directory on the NerveCenter Server host machine. The file contains messages about SNMP v3 operations and errors resulting from requests that originate with any connected NerveCenter Clients, Administrators, and Command Line interfaces.

When an error occurs after attempting to perform an SNMP v3 operation, aside from logging the error in the log file, the NerveCenter Server notifies all connected NerveCenter Clients and Administrators in the following ways:

- ◆ If you are logged on to the NerveCenter Client or Administrator that initiated the operation that caused an error condition, NerveCenter displays a dialog box with the error that is logged.
- ◆ If you are logged on to some other NerveCenter Client or Administrator (one that did not initiate the error condition), you see a red icon in the status bar. When you double-click the icon, a dialog box displays the NerveCenter Server with the SNMP v3 error. If your Client or Administrator is connected to more than one Server, the dialog box lists all servers that currently have an error condition.



NOTE

The dialogs are displayed only in NerveCenter Client, not in the NerveCenter Web Client.

When your NerveCenter Client or Administrator displays a dialog box with an error condition, you can do either of the following:

- ◆ Acknowledge the error condition by “signing the log.” When you sign the log, NerveCenter notes this fact in the log file and changes the red icon to green for all connected Clients and Administrators.
- ◆ Dismiss the dialog box without acknowledging the error condition. If you merely dismiss the dialog box, only the icon in your Client or Administrator turns green. For all other connected Clients and Administrators, the icon remains red and signals to those modules that the NerveCenter Server has some error that remains unacknowledged, or unsigned. Moreover, the Server does not indicate acknowledgment in the log file.

If the SNMP v3 operation affects a group of nodes (e.g., version change or classification failure), you will see only one instance for the group displayed in the error message dialog box. To see details for each node, you can look in the log file.

You must have administrator rights to initiate an SNMP v3 operation that can result in an error or to acknowledge a logged error condition. If you are logged on with only user rights, you can dismiss the error dialog box but not acknowledge an error condition.

Whether you acknowledge or dismiss the error, all messages remain in the v3messages.log for you to read.

For more information, refer to the following topics:

- ◆ *Signing a Log for SNMP v3 Errors Associated with Your Administrator on page 160*
- ◆ *Signing a Log for SNMP v3 Errors Associated with a Remote Client or Administrator on page 161*
- ◆ *Viewing the SNMP v3 Operations Log on page 163*

Signing a Log for SNMP v3 Errors Associated with Your Administrator

Whenever an SNMP v3 operation is requested or an error occurs while attempting an SNMP v3 operation, the NerveCenter Server logs a message to a file. If you are logged in to the NerveCenter Client that initiated the request causing a logged condition, NerveCenter displays a dialog box with the error that is logged.



FIGURE 9-2. Operations Log Error in Server Dialog Box for Your Client

Users with administrator rights can acknowledge a logged condition from NerveCenter Client by signing the Operations log. Signing the log causes the icon to turn green in all connected Clients/Administrators.

You can also dismiss the dialog box without acknowledging the error condition. If you are logged on with user rights rather than administrator rights, your only option is to dismiss the dialog box; you cannot sign the Operations log.

TO SIGN THE OPERATIONS LOG

1. After viewing the message that NerveCenter displays on your screen, check the Sign the log and dismiss errors checkbox.
2. Select **OK**.

The icon in the Status Bar turns green for all Clients or Administrators connected to the designated NerveCenter Server. You can later view this message again in the Operations log.

This file, named v3messages.log, resides in the NerveCenter installation log directory. The file can be viewed in a text editor or word processor.

TO DISMISS THE ERROR IN SERVER DIALOG BOX

- ◆ Select **OK** without checking the checkbox.

In this case, only the icon in your Client turns green. For all other connected Clients and Administrators, the icon remains red and signals to those modules that the NerveCenter Server has some error that remains unacknowledged.

Signing a Log for SNMP v3 Errors Associated with a Remote Client or Administrator

Whenever an error occurs while attempting an SNMP v3 operation, the NerveCenter Server logs a message to a file. If you are logged on to some remote NerveCenter Client (one that did not initiate the error condition), you see a red icon in the status bar.

Users with administrator rights can acknowledge a logged condition from NerveCenter Client by signing the Operations log. Signing the log causes the icon to turn green in all connected Clients/Administrators.

You can also dismiss the dialog box without acknowledging the error condition. If you are logged on with user rights rather than administrator rights, your only option is to dismiss the dialog box; you cannot sign the Operations log.

TO SIGN THE OPERATIONS LOG

1. Double-click the red icon in the Status Bar.

The Error In Server dialog box is displayed.

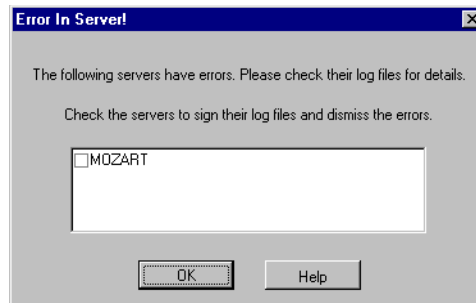

2. Check the NerveCenter Server or Servers for which you want to sign the log.
3. Select **OK**.

The icon in the Status Bar turns green for all Clients or Administrators connected to the servers you checked. At a suitable time, you can open the Operations log and view the new message. This file, named v3messages.log, resides in the NerveCenter installation log directory. The file can be viewed in a text editor or word processor.

TO DISMISS THE ERROR IN SERVER DIALOG BOX

1. Double-click the red icon in the Status Bar.

The Error In Server dialog box is displayed.

2. Select **OK** without checking any of the checkboxes.

In this case, only the icon in your Client turns green. For all other connected Clients and Administrators, the icon remains red and signals to those modules that the NerveCenter Server has some error that remains unacknowledged.

Viewing the SNMP v3 Operations Log

Whenever an SNMP v3 operation is requested or an error occurs while attempting the operation, the NerveCenter Server logs a message to a file. This log file, named `v3messages.log`, resides in the NerveCenter installation log directory on the NerveCenter Server host machine.

The file can be viewed in a text editor or word processor. As NerveCenter adds more messages to the file, the file continues to grow until you manually remove old messages.

The log entries resemble the following:

```
06/20/2000 09:26:29 Tue - Event ID : NC_SERVER; Category ID :
NC_THREAD_V3OP; Error Status : AutoClassifyFail; Error while communicating
using SNMPv1 for 10.52.174.51 because of : NC_PORT_UNREACHABLE;
```

Following are the fields in the log:

TABLE 9-1. Fields in the Operations Log

Field	Description
Date/Time	Date and time the record was logged. The format is month/day/year, hour/minute/second, and day (for example, 12/16/2000 11:32:29 Sat).
EventID	This always NC_SERVER.
CategoryID	Name of the thread where the event occurred.
Error Status	One of several error status strings. See <i>Error Status</i> for a description of SNMP v3 error status messages and which ones cause polling to stop for a node.
Error Description	Details of the error or operation.

SNMP Error Status

When NerveCenter is unable to complete an SNMP operation on a node, the error status is displayed in the Node List (NerveCenter Client and Web Client) and in the SNMP tab of the node's definition window (NerveCenter Client).

The following illustration shows the Node List window in the Client.

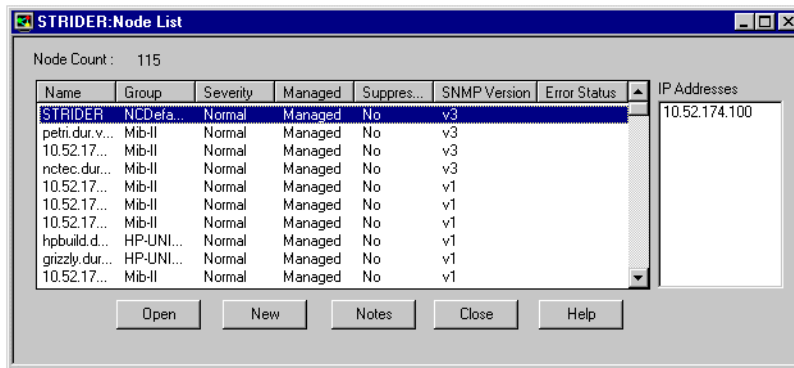

FIGURE 9-3. Node List Window

Though most of the error strings correspond to SNMP v3 errors, some are applicable for v1 and v2c errors as well. These are noted in the descriptions below.

Sometimes error conditions can be corrected simply by running the SNMP Test Version poll. Others may require configuration changes to the node's SNMP agent. After changing the configuration of an SNMP agent, always test communication with the node in NerveCenter Client prior to polling the node.

The following list describes each possible SNMP error status.

- ♦ **AuthKeyFail** – The change for the authentication key failed. Polling will not happen for nodes with this error. You must rectify the problem manually on the agent and use the Test Version poll to verify NerveCenter communication with this node.
- ♦ **PrivKeyFail** – The change for the privacy key failed. Polling will not happen for nodes with this error. You must rectify the problem manually on the agent and use the Test Version poll to verify NerveCenter communication with this node.
- ♦ **AuthPrivKeyFail** – Change for both the authentication and privacy keys failed. Polling will not happen for nodes with this error. You must rectify the problem manually on the agent and use the Test Version poll to verify NerveCenter communication with this node.

- ◆ **V3InitFail** – An attempt to get the engine ID failed and NerveCenter could not initialize the node. Polling will not happen for this node. You can try running the Test Version poll, which attempts to get the engine ID for this node again. Alternatively, if the node sends a trap that NerveCenter can decode, NerveCenter will then get the engine ID from that trap.
- ◆ **ClassifyFail** – At attempt to obtain the node’s version failed during a classification attempt. The version will be “Unknown” for this node and polling will not happen. You can manually change the version or try to classify the node again.
- ◆ **AutoClassifyFail** – At attempt to obtain the node’s version failed during a classification attempt while NerveCenter was using auto-classification. The version will be “Unknown” for this node and polling will not happen. You can manually change the version or try to classify the node again.

**NOTE**

ClassifyFail and AutoClassifyFail status values are not limited to SNMP v3 agents. If NerveCenter attempts classification of an agent and the classification attempt fails for some reason (e.g., the agent is down), NerveCenter will mark the node with ClassifyFail or AutoClassifyFail regardless of the SNMP version supported on the agent.

- ◆ **TestVersionFail** – At attempt to poll the SNMP agent failed. The Test Version poll sends a GetRequest message for a node based on the SNMP version configured for that node.

If the Test Version poll fails, polling will not happen for this node. In that case, you may need to reconfigure the agent on this node. Then, try running the Test Version poll again (from a node’s definition window or the right-click menu in the node list).

**NOTE**

TestVersionFail is not limited to SNMP v3 agents. You can test the version of any SNMP agent with this feature.

- ◆ **Configuration Mismatch** – Indicates an SNMP trap was received but there is some problem with the configuration on the agent. If NerveCenter is unable to decode a trap due to some unspecified reason (e.g., unsupported authentication or privacy parameters on the agent, or an incorrect NerveCenter user name), NerveCenter can receive the trap and add the node to its database if NerveCenter is configured to discover nodes via traps. After adding the node to its database, however, NerveCenter assigns an error status of Configuration Mismatch.

**NOTE**

Any error that occurs during the decoding of traps always results in a Configuration Mismatch error message.

- ◆ **TimeSyncFail** – An attempt to get the engine boots/timeticks failed for the node. Polling will continue for this node. If any polls successfully reach the node, the node responds with an “Out of time window” report PDU that contains the correct boots/timeticks, and NerveCenter can then update this information for the node. For the initial polls that generate the report PDU, the `SNMP_NOT_IN_TIME_WINDOW` trigger will be fired.

You can ignore this message, which simply indicates that NerveCenter is getting in sync with that node. Moreover, it is easy to recover from this error status. Right-click the node in the Node List and select `v3TestPoll`. If the agent corresponding to the node is up, the test poll should be successful and NerveCenter will clear the error message.

NerveCenter will not poll any nodes whose error status is one of the following:

- ◆ `AuthKeyFail`
- ◆ `PrivKeyFail`
- ◆ `AuthPrivKeyFail`
- ◆ `TestVersionFail`
- ◆ `V3InitFail`
- ◆ `ClassifyFail`

SNMP Agent

NerveCenter includes a Master SNMP Agent and an SNMP Sub-Agent so that you can monitor NerveCenter with a third party SNMP application, such as HP OpenView. The data provided by the NerveCenter SNMP Agent is described in the MIB modules located in *InstallPath/mibs/nsmg*.

When you install NerveCenter, you also install the SNMP Master and Sub Agents, however they are disabled by default. You need to first configure the SNMP Agent and then enable it before it can process SNMP requests. When you enable the SNMP Agent for the first time, the Agent is added to the set of Services or Daemons running on the host system.

TO CONFIGURE THE NERVECENTER SNMP AGENT

1. Open NerveCenter Administrator and connect to the appropriate NerveCenter Server. See [Connecting Administrator to a NerveCenter Server on page 44](#).
2. Select the **SNMP Agent** tab.

The SNMP Agent tab is displayed.

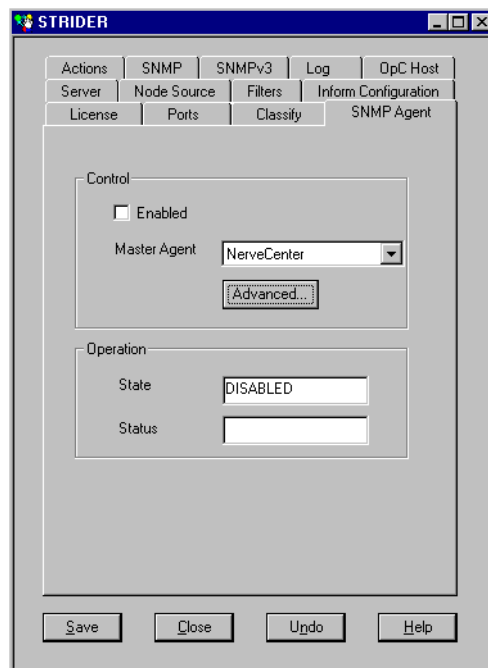

3. Select **NerveCenter** from the Master Agent list.
4. Click **Advanced**.

The NerveCenter Master Agent dialog box displays.



NOTE

You can only make changes to the NerveCenter Master Agent dialog box if the SNMP Agent is disabled. See [To disable the NerveCenter SNMP Agent on page 169](#).

5. Enter the **UDP Port** from which you want the Master Agent to send SNMP messages.
6. Enter the **sysName** (system name), **sysContact** (system contact), and **sysLocation** (system location) in the appropriate fields.
7. Select the versions of SNMP you want to support.
8. If you select SNMPv1 or SNMPv2c, enter **Read Community** and **Write Community** strings.



NOTE

SNMP Set is disabled for this release of NerveCenter.

If you select SNMPv3, use the security settings defined on the SNMPv3 tab. See [SNMP v3 Security Settings on page 155](#) for more details.

9. Click **OK**.

You return to the SNMP Agent tab.

10. Select the **Enabled** check box.

**NOTE**

To enable the SNMP Agent on UNIX, the NerveCenter server must be running as a process with root privileges.

11. Click **Save**.

If you want to limit network traffic, or have no more need of the SNMP Agent, you can turn it off.

**NOTE**

To disable the SNMP Agent on UNIX, the NerveCenter server must be running as a process with root privileges.

TO DISABLE THE NERVECENTER SNMP AGENT

1. Open NerveCenter Administrator and connect to the appropriate NerveCenter Server. See [Connecting Administrator to a NerveCenter Server on page 44](#).
2. Select the **SNMP Agent** tab.
The SNMP Agent tab is displayed.
3. Clear the **Enabled** check box.
4. Click **Save**.

Besides the SNMP Master Agent configuration, you also need to configure the settings between the SNMP Sub Agent and the NerveCenter server.

TO CONFIGURE COMMUNICATION BETWEEN THE SNMP SUB AGENT AND NERVECENTER SERVER**NOTE**

You can only make changes to the NerveCenter Master Agent dialog box if the SNMP Agent is disabled. See [To disable the NerveCenter SNMP Agent on page 169](#).

1. Open NerveCenter Administrator and connect to the appropriate NerveCenter Server. See [Connecting Administrator to a NerveCenter Server on page 44](#).
 2. Select the **SNMP Agent** tab.
The SNMP Agent tab is displayed.
 3. Click **Advanced**.
The NerveCenter Master Agent dialog box displays.
 4. Enter the TCP **Port** number for the communication between the SNMP Sub Agent and the NerveCenter Server.
The default value for this field is 32503.
 5. Enter the contact information for the SNMP Sub Agent.
Use this field to indicate the person(s) responsible for the NerveCenter service on this host.
 6. Click **OK**.
You return to the SNMP Agent tab.
 7. Click **Save**.
-

NerveCenter security allows access for two different groups. A NerveCenter administrator must add users to an appropriate user group before they can use NerveCenter.



NOTE

On Windows, NerveCenter can be installed without security. If NerveCenter is installed without security, users do not need to enter a name and password when logging on to the server.

On Windows, the NerveCenter Server authenticates users against the Windows built-in security. On UNIX, the NerveCenter Server authenticates users against the local machine or an NIS database. Membership in the appropriate groups determines what privileges users have within NerveCenter.



NOTE

The user ID under which the NerveCenter Server runs on Windows must be a member of the NerveCenter Admins group. On UNIX, root must run the server; however, after the server initializes, control is given to the `nervectr` user, which is a member of `ncadmins`.

Members of the `ncadmins` group on UNIX or the NerveCenter Admins group on Windows can configure NerveCenter and create and modify behavior models. Members of the `ncusers` group on UNIX or the NerveCenter Users group on Windows can monitor network status and reset alarms. For more details about privileges, see the section *NerveCenter Login Rights on page 35*.

This chapter includes the following sections:

Section	Description
<i>Managing Security on UNIX on page 172</i>	Explains how to add users to user groups on UNIX.
<i>Managing Security on Windows on page 172</i>	Explains how to add users to user groups on Windows.

Managing Security on UNIX

During a NerveCenter installation, the `ncadmins` and `ncusers` groups and the `nervectr` user, which is a member of `ncadmins`, are created. After installation, a NerveCenter administrator must add users to the appropriate groups.

Use the following guidelines when adding users to groups:

- ◆ Add NerveCenter administrators to the `ncadmins` group. See *The Role of a NerveCenter Administrator* on page 36.
- ◆ Add NerveCenter users to the `ncusers` group. NerveCenter users will only use the NerveCenter Client to monitor networks.

Managing Security on Windows

Unless the person installing NerveCenter chose to install NerveCenter without security, NerveCenter Setup automatically creates two groups with the required login rights—NerveCenter Admins and NerveCenter Users. Setup also automatically adds to the NerveCenter Admins group the user ID of the person who installs NerveCenter.



NOTE

The person who installs NerveCenter must have the rights to create either local or global groups. If not, NerveCenter will not create these groups successfully.

Setup creates these groups differently depending on where you install NerveCenter.

- ◆ If you install on a Windows workstation or server, NerveCenter Setup creates two local groups. These two local groups must be on every machine that runs NerveCenter.
- ◆ If you install on an Windows primary or backup domain controller, NerveCenter Setup creates two global groups on the primary domain controller.

You can also create other groups that are members of one of the NerveCenter groups.

There are three scenarios for adding NerveCenter users:

- ◆ *Adding Users to a NerveCenter on a Windows Workstation or Server* on page 173
- ◆ *Adding Users to a NerveCenter on a Windows Domain Controller* on page 175
- ◆ *Working with Active Directory* on page 177

Adding Users to a NerveCenter on a Windows Workstation or Server

This section describes how to add users to NerveCenter groups if you install NerveCenter on a Windows workstation or server. Use the following guidelines when adding users to groups:

- ◆ Add NerveCenter administrators to the ncadmins group. See *The Role of a NerveCenter Administrator on page 36*.
- ◆ Add NerveCenter users to the ncusers group. NerveCenter users will only use the NerveCenter Client to monitor networks. See *NerveCenter Login Rights on page 35* for a more detailed discussion of permissions.

Remember, once you add users to a group, they must log out and back in for changes to take effect.

TO ADD USERS TO THE LOCAL GROUPS

- ◆ Use Windows User Manager to add your users to one of the two local groups to make sure they have the correct advanced user rights to use NerveCenter.



NOTE

You must have Admin rights on your local machine to add users to local groups.

TO CREATE GLOBAL GROUPS THAT ARE MEMBERS OF THE LOCAL GROUPS

1. On the primary domain controller, create one more global groups with the following advanced user rights:
 - ◆ Act as part of the operating system
 - ◆ Log on as batch
2. Use Windows User Manager for Domains to add your users to one of the two global groups.

**NOTE**

You must have Domain Admin rights to add users to the global groups.

3. Add these global groups as members of the NerveCenter Admins and NerveCenter Users groups on each local machine that is running a NerveCenter Server.

Instead of global groups, you could add each of your users to the groups on each of the local machines manually. However, for convenience, we recommend using the global groups.

**NOTE**

You must have Admin rights on the local machine to add users to the local groups.

IF SOME OF YOUR USERS ARE ON ANOTHER DOMAIN, FOLLOW THESE ADDITIONAL STEPS

1. Add each user to one of the NerveCenter global groups on the domain to which the NerveCenter Server belongs.

Doing this ensures that those users have the correct advanced user rights.

**NOTE**

You must have Domain Admin rights to add users to the global groups.

You must also set up a two-way trust relationship between the two domains. See the Windows documentation for more information.

2. Tell your users to specify their domain along with their user IDs whenever NerveCenter prompts them for their user ID.
-

The NerveCenter Server authenticates users first by evaluating which group they belong to and then by evaluating the validity of their Windows user ID and password.

Adding Users to a NerveCenter on a Windows Domain Controller

This section describes how to set up the NerveCenter groups and membership in those groups if you install a NerveCenter Server on a Windows domain controller. Use the following guidelines when adding users to groups:

- ◆ Add NerveCenter administrators to the ncadmins group. See *The Role of a NerveCenter Administrator on page 36*.
- ◆ Add NerveCenter users to the ncusers group. NerveCenter users will only use the NerveCenter Client to monitor networks. See *NerveCenter Login Rights on page 35* for a more detailed discussion of permissions.

Remember, once you add users to a group, they must log out and back in for changes to take effect.

If you install the NerveCenter Server on a Windows domain controller, Setup creates the global groups NerveCenter Admins and NerveCenter Users automatically.

TO SET UP USERS

1. Use Windows User Manager for Domains to add your users to one of the two global groups.

**NOTE**

You must have Domain Admin rights to add users to the global groups.

2. Add these global groups as members of the NerveCenter Admins and NerveCenter Users groups on each local machine that is running a NerveCenter Server.

**NOTE**

You must have Admin rights on the local machine to add users to the local groups.

IF SOME OF YOUR USERS ARE ON ANOTHER DOMAIN

1. Add each user to the NerveCenter global groups on the domain to which the NerveCenter Server belongs.

Doing this ensures that those users have the correct advanced user rights.

**NOTE**

You must have Domain Admin rights to add users to global groups. You must set up a two-way trust relationship between the two domains. See your Windows documentation for more information.

2. Tell your users to specify their domains along with their user IDs whenever they are prompted for User ID by NerveCenter.
-

The NerveCenter Server authenticates users first by evaluating which group they belong to and then by evaluating the validity of their Windows user ID and password.

Working with Active Directory

If you are managing your users and groups with Active Directory, you can configure NerveCenter to connect to your Active Directory server. NerveCenter Setup still creates the local groups NerveCenter Admins and NerveCenter Users on the NerveCenter server machine, however you can manage user and administrator credentials through Active Directory instead.

Within Active Directory:

- ◆ Create NerveCenter Admins and NerveCenter Users groups.
- ◆ Add users to the appropriate groups.

Once you have configured NerveCenter to connect to the Active Directory server as described in [To connect to an Active Directory server](#), you can login to NerveCenter using usernames and passwords defined with Active Directory.



CAUTION

Once you have connected to an Active Directory server, you can no longer use the local NerveCenter usernames and passwords; you can only log in with credentials defined on the Active Directory server.

You should confirm that NerveCenter Admins and NerveCenter Users exist on the Active Directory server before connecting NerveCenter to the Active Directory server.

TO CONNECT TO AN ACTIVE DIRECTORY SERVER

1. Open NerveCenter Administrator and connect to the appropriate Server.

See [Connecting Administrator to a NerveCenter Server on page 44](#).

2. Select the **Server** tab.

The Server page is displayed.

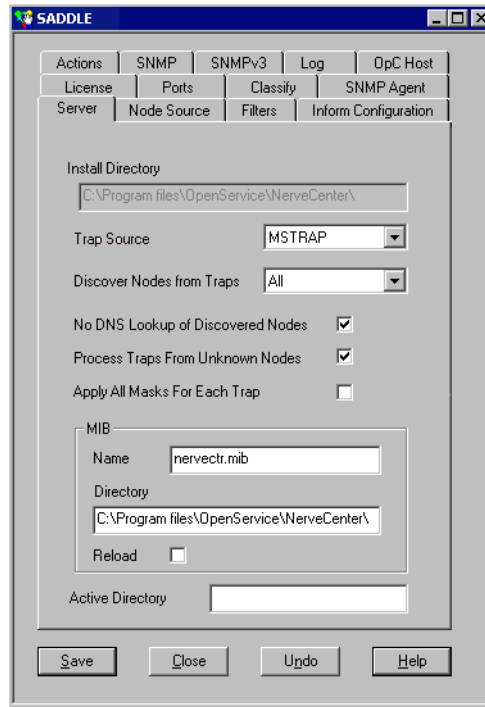

3. Enter the full host name or IP address of the Active Directory Server in the Active Directory field.

If you have configured Active Directory to use a port other than the default port of 389, you can also enter the port using the format *IPAddress:Port*.

4. Select **Save**.

Troubleshooting: Managing NerveCenter Security

The following list contains some common security problems NerveCenter users face.

Users cannot connect to the server

Problem: Users are not members of the appropriate NerveCenter user group on the server machine (ncadmins or ncusers on UNIX or NerveCenter Admins or NerveCenter Users on Windows).

Solution: Check group membership. If users are not members of the appropriate groups, add them. Remember that on Windows, users must log out for changes to take place.

See *Managing Security on UNIX on page 172* or *Managing Security on Windows on page 172*.

Problem: Users do not have a valid Windows account.

Solution: Check the user account. See your Windows documentation for more details.

Problem: The server is not running.

Solution: Restart the server.

See *Chapter 4, Running the NerveCenter Server*

Users in ncadmins or ncusers on UNIX cannot connect to the server

Problem: ncadmins and ncusers have been created on a NerveCenter host that is also an NIS client.

Solution: When running NerveCenter on an NIS client, the groups ncadmins and ncusers must reside on the NIS Master. Local NerveCenter groups are ignored when the local system is an NIS client. Authentication is done on the NIS Master server. When running in an NIS environment, make sure the NerveCenter groups are defined on the NIS master. The user community members must be members of those groups as well.

See *Installing NerveCenter*.

Anyone can connect to a Windows server

Problem: NerveCenter was installed on Windows without security.

Solution: Reinstall the NerveCenter server with security.

See *Installing NerveCenter*.

User can monitor alarms, but can't modify behavior models

Problem: Users who are members of ncusers (UNIX) or NerveCenter Users (Windows) can only monitor and reset alarms. To be able to modify NerveCenter objects, users must be members of ncadmins (UNIX) or NerveCenter Admins (Windows).

Solution: Add users to the appropriate groups.

See *Managing Security on UNIX on page 172* or *Managing Security on Windows on page 172*.

User cannot connect to the NerveCenter Web client.

Problem: User does not have the appropriate permissions on the Web server.

Solution: Give the user access to the Web server. See your Web server documentation for details.

Managing NerveCenter Alarm Actions

Alarm actions are important components of NerveCenter behavior models. The user supplies most of the data needed to perform the alarm action when the behavior model is created. However, before some alarm actions can be performed, an administrator must configure particular settings.

This chapter includes the following sections:

Section	Description
<i>Specifying an SMTP Server for Mail Notification on page 182</i>	Explains how to configure NerveCenter to send e-mail notifications via an SMTP server.
<i>Configuring NerveCenter to Send Microsoft Mail on page 184</i>	Explains the various scenarios in which you may configure NerveCenter to send messages via a Microsoft Exchange server.
<i>Setting Dialing Properties for Paging Notification on Windows on page 190</i>	Explains how to configure NerveCenter on Windows to send pages.
<i>Setting Dialing Properties for Paging Notification on UNIX on page 192</i>	Explains how to configure NerveCenter on UNIX to send pages.
<i>Specifying Settings for Log Management on page 194</i>	Explains how to configure NerveCenter to manage logs.
<i>Troubleshooting: Managing Alarm Actions on page 197</i>	Lists common problems NerveCenter users face when using alarm actions.

Specifying an SMTP Server for Mail Notification

In the event of noteworthy network conditions, NerveCenter can alert the necessary person via e-mail. NerveCenter currently offers two options for having a behavior model send an e-mail message:

- ◆ With an SMTP server.
- ◆ With a Microsoft Exchange server. See *Configuring NerveCenter to Send Microsoft Mail on page 184*.

The recipient or recipients of the SMTP mail message is specified when the behavior model is created. However, before this message can be sent, the administrator must specify which SMTP server NerveCenter uses to send the message.



NOTE

On UNIX, the nervectr user is the sender of SMTP mail. To change this default sender, you can create an alias. Refer to your mail documentation for details.

TO SPECIFY A SMTP SERVER FOR MAIL NOTIFICATION

1. Open NerveCenter Administrator and connect to the appropriate NerveCenter Server. See *Connecting Administrator to a NerveCenter Server on page 44*.

2. Select the **Actions** tab.

The Actions tab is displayed.

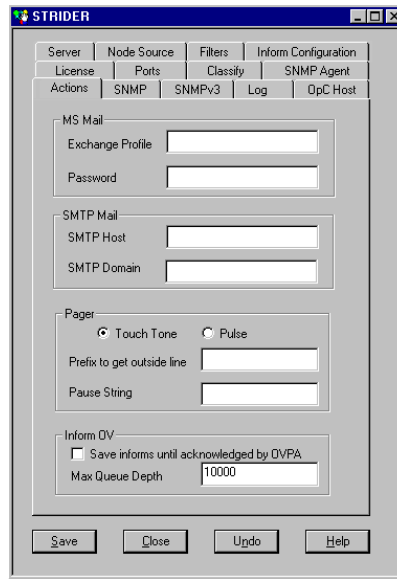

The screenshot shows the STRIDER configuration window with the following sections:

- MS Mail:** Exchange Profile (text field), Password (text field).
- SMTP Mail:** SMTP Host (text field), SMTP Domain (text field).
- Pager:** Touch Tone (selected radio button), Pulse (radio button), Prefix to get outside line (text field), Pause String (text field).
- Inform DV:** Save informs until acknowledged by DVPA (checkbox), Max Queue Depth (text field with value 10000).

Buttons at the bottom: Save, Close, Undo, Help.

3. In the **SMTP Host** field, type the name of the host running your SMTP mail server.
4. If you require a domain name other than the local host sending the mail, enter a valid domain name in the **SMTP Domain** field.

**NOTE**

If the **SMTP Domain** is empty, NerveCenter will use the local host name as the domain name.

5. Select **Save**.

Users can now include a SMTP Mail action in their behavior models.

Configuring NerveCenter to Send Microsoft Mail

In the event of noteworthy network conditions, NerveCenter can alert the necessary person via e-mail. NerveCenter currently offers two options for having a behavior model send an e-mail message:

- ◆ With an SMTP server. (See *Specifying an SMTP Server for Mail Notification on page 182.*)
- ◆ With a Microsoft Exchange server.

**NOTE**

To use the Microsoft mail alarm action, the NerveCenter Server must be running on a Windows platform.

The recipient or recipients of the Microsoft mail message is specified when the behavior model is created. However, before this message can be sent, the administrator must configure the Exchange profile that is sending the message.

There are two possible scenarios recommended for configuring the profile sending Microsoft Mail. In both cases a Microsoft Exchange Server administrator will need to create and designate a Microsoft Exchange mailbox specifically for NerveCenter purposes. The two different scenarios depend on how you will be running the NerveCenter Server:

- ◆ *Configuring NerveCenter to Send Microsoft Mail While Running as a Service on page 185*
- ◆ *Configuring NerveCenter to Send Microsoft Mail while Running the Server as a Process on page 188*

**CAUTION**

There are other scenarios in which the Microsoft Mail action can be used without creating a global NerveCenter group or account. However, they involve switching Exchange profiles each time a new user logs in to the NerveCenter machine.

Configuring NerveCenter to Send Microsoft Mail While Running as a Service

It is recommended that you run the NerveCenter Server as a Windows service because it simplifies accounts and other network domain concerns. To configure NerveCenter to send Microsoft mail properly, you must have a network administrator create a separate NerveCenter account and Exchange mailbox.

TO CONFIGURE NERVECENTER TO SEND MICROSOFT MAIL WHILE RUNNING NERVECENTER SERVER AS A SERVICE

1. Have your Microsoft Exchange Server administrator create a mailbox for NerveCenter purposes.

Although the mailbox name could be anything, for ease of use it is recommended you ask your Microsoft Exchange Server administrator to use the name NerveCenter.

2. Have your network administrator create an account in the Primary Domain Controller with access rights to the NerveCenter-designated mailbox created in step 1.

Although the account name could be anything, for ease of use it is recommended you ask your administrator to use the name NerveCenter.

3. Change the account under which the NerveCenter Server service will be running.

By default, when NerveCenter Server is installed as a service it is placed under the system account. To change the account:

- a. From the **Start** menu, select **Settings**, then **Control Panel**.
- b. Double-click the **Services** icon.
The Services window appears.
- c. In the Service list, highlight NerveCenter and select **Startup**.
The NerveCenter Service window opens.



- d. In the **Log On As** area, select **This Account**.
The System Account setting is deselected.
- e. In the **This Account** field, select the NerveCenter-designated account created in step 2.
- f. In the **Password** and **Confirm Password** fields, type the password assigned to the NerveCenter-designated account.
- g. Select **OK**.

You have now specified that the NerveCenter Server service will run under the NerveCenter-designated account that has access rights to the NerveCenter-designated mailbox in the Microsoft Exchange Server.

4. On the machine that will run NerveCenter Server, create a NerveCenter-designated Exchange profile to point to the machine hosting the Microsoft Exchange Server and the NerveCenter-designated mailbox created in step 1.

Although the account name could be anything, for ease of use it is recommended you use the name NerveCenter.

5. Open the NerveCenter Administrator and connect to the appropriate NerveCenter Server. See [Connecting Administrator to a NerveCenter Server on page 44](#).
6. Select the **Actions** tab.

The Actions tab appears.

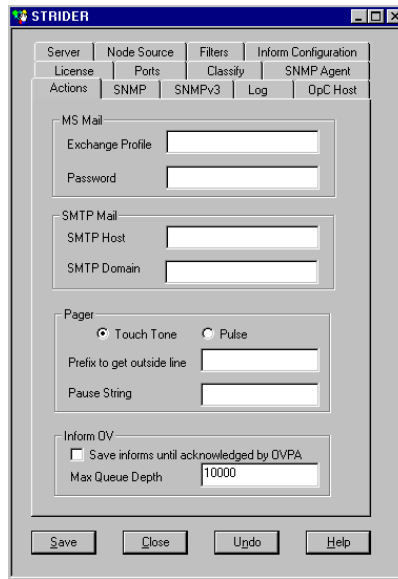

7. In the **Exchange Profile** field, type the name of the NerveCenter-designated profile created in step 4.
8. Select **Save**.

Users can now include a Microsoft Mail action in their behavior models. The message will be sent from the mailbox created in step 1.

Configuring NerveCenter to Send Microsoft Mail while Running the Server as a Process

It is recommended that you run the NerveCenter Server as a Windows service because it simplifies accounts and other network domain concerns. See [Configuring NerveCenter to Send Microsoft Mail While Running as a Service on page 185](#).

Should you choose, however, to run NerveCenter Server as a process, you must have a network administrator create a global group for all your NerveCenter administrators as well as a Microsoft Exchange mailbox specifically for NerveCenter.

TO CONFIGURE NERVECENTER TO SEND MICROSOFT MAIL WHILE RUNNING THE NERVECENTER SERVER AS AN APPLICATION BY ESTABLISHING A GLOBAL GROUP

1. Have your network administrator create a global group in the Primary Domain Controller. Include in this group any user who should have administrator privileges in NerveCenter.

Although the account name could be anything, for ease of use it is recommended you ask your network administrator to use the name NerveCenter Admins.

2. Have your Microsoft Exchange Server administrator create a mailbox for NerveCenter purposes.

Although the mailbox name could be anything, for ease of use it is recommended you ask your Microsoft Exchange Server administrator to use the name NerveCenter.



NOTE

The Exchange Server administrator should make sure the Primary Windows Account for this NerveCenter-designated mailbox is the NerveCenter administrators-designated global group created in step 1.

3. On each machine that will run NerveCenter Server, create a NerveCenter-designated Exchange profile to point to the machine hosting the Microsoft Exchange Server and the NerveCenter-designated mailbox created in step 1.

Although the profile name could be anything, for ease of use it is recommended you use the name NerveCenter.

4. Open NerveCenter Administrator and connect to the appropriate NerveCenter Server. See [Connecting Administrator to a NerveCenter Server on page 44](#).
5. Select the **Actions** tab.

The Actions tab appears.

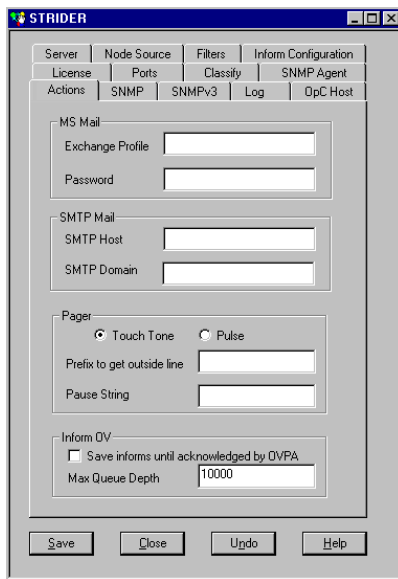

6. In the **Exchange Profile** field, type the name of the NerveCenter-designated profile created in step 4.
7. Select **Save**.
8. All new users assigned administrator privileges locally to a NerveCenter Admins group must be added to the global NerveCenter Administrators-designated group as well.

Users can now include a Microsoft Mail action in their behavior models. The message will be sent from the mailbox created in step 2.

Setting Dialing Properties for Paging Notification on Windows

In the event of noteworthy network conditions, NerveCenter can call the necessary person's pager. Data about the recipient's pager is specified when the behavior model is created. However, before the page can be sent, an administrator must configure basic settings concerning the server's dialing properties.

This section describes how to set dialing properties for a NerveCenter Server on Windows. See [Setting Dialing Properties for Paging Notification on UNIX on page 192](#).



NOTE

A paging NerveCenter Server must have access to a TAPI-compliant modem and access to an outside line.

TO CONFIGURE NERVECENTER TO PERFORM THE PAGING ACTION ON WINDOWS

1. Open NerveCenter Administrator and connect to the appropriate NerveCenter Server. See [Connecting Administrator to a NerveCenter Server on page 44](#).
2. Select the **Actions** tab.

The Actions tab is displayed.

The screenshot shows the STRIDER configuration window with the 'Actions' tab selected. The window has a title bar with 'STRIDER' and standard window controls. Below the title bar is a tabbed interface with the following tabs: Server, Node Source, Filters, Inform Configuration, License, Ports, Classify, SNMP Agent, Actions (selected), SNMP, SNMPv3, Log, and OpC Host. The main content area is divided into several sections:

- MS Mail:** Contains two text input fields for 'Exchange Profile' and 'Password'.
- SMTP Mail:** Contains two text input fields for 'SMTP Host' and 'SMTP Domain'.
- Pager:** Contains two radio buttons for 'Touch Tone' (selected) and 'Pulse'. Below them are two text input fields for 'Prefix to get outside line' and 'Pause String'.
- Inform OV:** Contains a checkbox for 'Save informs until acknowledged by OVPA' (unchecked) and a text input field for 'Max Queue Depth' with the value '10000'.

At the bottom of the window are four buttons: 'Save', 'Close', 'Updo', and 'Help'.

3. In the **Pager** area, select either **Touch Tone** or **Pulse**.
 4. In the **Prefix to get outside line** field, type the number or numbers for an outside line.
In many offices, for example, you dial 9 for an outside line.
 5. In the **Pause String** field, type the characters used to create a pause between dialing and sending data.
 6. Select **Save**.
-

Users can now include a Paging action in their behavior models.

Setting Dialing Properties for Paging Notification on UNIX

In the event of noteworthy network conditions, NerveCenter can call the necessary person's pager. Data about the recipient's pager is specified when the behavior model is created. However, before the page can be sent, an administrator must configure basic settings concerning the server's dialing properties.

This section describes how to set dialing properties for a NerveCenter Server on UNIX. See also [Setting Dialing Properties for Paging Notification on Windows on page 190](#).



NOTE

A paging NerveCenter Server must be on a machine with a modem and access to a outside line.

TO CONFIGURE NERVECENTER TO PERFORM THE PAGING ACTION ON UNIX

1. Open NerveCenter Administrator and connect to the appropriate NerveCenter Server. See [Connecting Administrator to a NerveCenter Server on page 44](#).
2. Select the **Actions** tab.

The Actions tab is displayed.

COBALT

Server | Node Source | Filters | Inform Configuration

License | Ports | Classify | SNMP Agent

Actions | SNMP | SNMPv3 | Log | OpC Host

SMTP Mail

SMTP Host

SMTP Domain

Pager

Log File: /tmp/pager.log

Maximum Retries: 5

Retry Interval (sec): 120

Modem Speed: 1200

Pager Port: /dev/cua/a

Inform OV

Save informs until acknowledged by OVPA

Max Queue Depth: 10000

Save Close Undo Help

3. In the **Log File** field, type the full path and name of the pager log file.

The Pager action logs messages about success or failure to this file. Each log entry contains the following:

- ◆ a date and time stamp
- ◆ the process ID (PID) of the Pager process
- ◆ the log message itself

If, for some reason, the log file cannot be opened, all log messages are directed to standard error (stderr).

4. In the **Maximum Retries** field, type the maximum number of times the system should try to dial the pager number.
 5. In the **Retry Interval** field, type the number of seconds you want NerveCenter to wait between dialing.
 6. In the **Modem Speed** field, type the speed of the modem used for paging.
 7. In the **Pager Port** field, type the location of the port used for paging.
 8. Select **Save**.
-

Users can now include a Paging action in their behavior models.

Specifying Settings for Log Management

NerveCenter offers two ways that a behavior model can log network data:

- The Log to File alarm action writes information about an alarm transition to an ASCII text file.
- The Log to Database alarm action, available only on Windows systems, writes information about an alarm transition to the NerveCenter database. You can extract logged data from the database using any ODBC-compliant reporting tool.

When a behavior model is created, the user specifies the name of the log as well as the type of data that will be recorded. However, an administrator must specify how NerveCenter will manage these logs.

NerveCenter logs have changed over the course of several releases. Some of the more significant characteristics of NerveCenter logs include:

- Time fields appear in the following format:

```
mm/dd/yy hh.mm.ss day
```

For example, 10/04/98 12.03.44 Wed

- NerveCenter will delimit fields with a semi-colon
- No spaces will appear around the equal sign (=)
- Values will appear in the following format:

```
attribute.instance=value
```

For example, ifInOctets.3=5

- NerveCenter will print all fields when a default format is chosen. For example, the same trap in verbose and nonverbose format:

```
verbose: Time=11/11/2002 15:14:43 Mon; LogId=4894;
DestStateSev=Normal; NodePropertyGroup=Mib-II;
NodeName=MyComputer; AlarmName=AllTraps_LogToFile;
OrigState=Ground; TriggerName=allTraps; DestState=Logging;
TrapPduTime=321; TrapPduGenericNumber=4;
TrapPduEnterprise=1.3.6.1.41.78; TrapPduSpecificNumber=0;
TriggerInstance=; TriggerBaseObject=
```

```
nonverbose: 11/11/2002 15:14:43 Mon;4875;Normal;Mib-
II;MyComputer;AllTraps_LogToFile;Logging;allTraps;Logging;321;4;1.3.
6.1.41.78;0;;
```

TO SPECIFY THE SETTINGS NERVECENTER USES TO MANAGE LOGGING

1. Open NerveCenter Administrator and connect to the appropriate NerveCenter Server. See [Connecting Administrator to a NerveCenter Server on page 44](#).
2. Select the **Log** tab.

NerveCenter displays the Log tab.

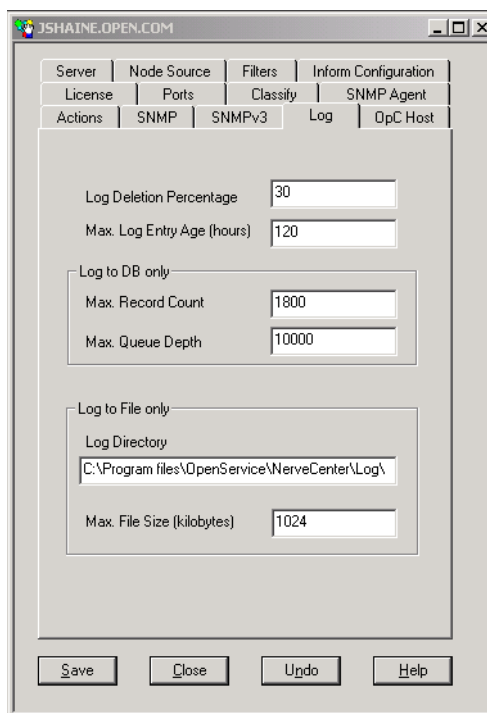

3. In the **Log Directory** field, type the complete path of the directory where NerveCenter stores the log.

By default, this field specifies a Log folder created in the NerveCenter directory during installation.

4. In the **Max Log Entry Age** field, type the number of hours you want to keep individual log entries before they are deleted from the rest of the log.

The way NerveCenter uses this number depends on which logging action is performed:

- ◆ Log to File: NerveCenter checks every file every 20th entry. It deletes any entry it finds that is older than the maximum age specified.
 - ◆ Log to Database: NerveCenter waits until the log reaches its size limit. It then deletes any entry it finds that is older than the maximum age specified.
5. In the **Max Log File Size** field, type the size limit, in kilobytes, of the ASCII text file storing the results of the Log to File alarm action.

This field does not affect the Log to Database alarm action.

6. In the **Max. Number of Records** field, type the highest number of records in the database file storing the results of the Log to Database alarm action.

This field does not affect the Log to File alarm action.

7. In the **Max. Queue Depth** field, type the highest number of changes that you want queued before saving to the database.

When the maximum is reached, no more changes are saved until the queue is reduced. You can have more than one change queued for a single database record.

8. In the **Log Deletion Percentage** field, type the percentage of the log to clear when the maximum file size or the maximum number of records is reached.

This field applies to both the Log to File and Log to Database alarm actions:

- ◆ Log to File: NerveCenter checks a log file every 20th entry. If the file log exceeds the amount specified in the Max Log File Size, NerveCenter deletes the percentage specified here, starting with the oldest entries.
 - ◆ Log to Database: NerveCenter checks a database log every 20th entry. If the database log exceeds the amount specified in the Max. Number of Records field, NerveCenter first deletes any records older than the age specified by the Max Log Entry Age. If the database log still exceeds the allowable amount, NerveCenter removes the percentage specified here, starting with the oldest entries.
9. Select **Save**.
-

NerveCenter will manage logs according to these settings whenever the Log to File or Log to Database alarm actions are used in a behavior model.

Troubleshooting: Managing Alarm Actions

The following list contains some common problems users have when using alarm actions.

NerveCenter is not sending SMTP mail notifications

Problem: A SMTP Server is not specified.

Solution: Specify a SMTP host under the Actions tab of the NerveCenter Administrator.

See *Specifying an SMTP Server for Mail Notification on page 182*.

Microsoft mail notifications are not being sent as NerveCenter

Problem: An incorrect Microsoft Exchange profile is specified.

Solution: Create a correct Microsoft Exchange profile and specify the profile under the Actions tab of the NerveCenter Administrator.

See *Configuring NerveCenter to Send Microsoft Mail on page 184*.

NerveCenter is not dialing pages correctly

Problem: The dialing properties are incorrect.

Solution: Set the correct dialing properties for paging under the Actions tab of the NerveCenter Administrator.

See *Setting Dialing Properties for Paging Notification on Windows on page 190* or *Setting Dialing Properties for Paging Notification on UNIX on page 192*.

The logs created by my behavior models are using too much disk space

Problem: The size limits for NerveCenter logging actions are too high.

Solution: Set the maximum sizes to an adequate limit.

See *Specifying Settings for Log Management on page 194*.

Managing NerveCenter Web Integration

NerveCenter alarms can be monitored using a standard web browser. To connect to a NerveCenter Server, the NerveCenter Web Collector must be installed and running on the machine hosting your web server. As an administrator, you must make sure the Web Collector is running and your web server is configured to work with NerveCenter.

This chapter includes the following section:

Section	Description
<i>How to Start and Stop the NerveCenter Web Collector on page 199</i>	Explains how to start and stop the NerveCenter Web Collector to allow for web integration.
<i>Configuring a Web Server for NerveCenter on page 201</i>	Explains how to configure a web server if it was not present when NerveCenter was installed.

How to Start and Stop the NerveCenter Web Collector

During a typical installation, the NerveCenter Web Collector is installed as a Windows service or UNIX daemon. Therefore, whenever you boot the host machine, the NerveCenter Web Collector will automatically start.

There may be times when you want to start or stop the NerveCenter Web Collector manually. The procedure depends on your operating system:

- ◆ *Starting and Stopping the NerveCenter Web Collector in UNIX on page 200.*
- ◆ *Starting and Stopping the NerveCenter Web Collector in Windows on page 200.*

Starting and Stopping the NerveCenter Web Collector in UNIX

During a typical installation, the NerveCenter Web Collector is installed as a daemon. Therefore, whenever you boot the host machine, the NerveCenter Web Collector will automatically start.

However, there may be times when you want to start or stop the NerveCenter Web Collector manually.

TO START OR STOP THE NERVECENTER WEB COLLECTOR

- ◆ To start the NerveCenter Web Collector, type at the command line:

```
ncwebstart
```

- ◆ To stop the NerveCenter Web Collector, type at the command line:

```
ncwebstop
```

Starting and Stopping the NerveCenter Web Collector in Windows

During a typical installation, the NerveCenter Web Collector is installed as a Windows service. Therefore, whenever you boot the host machine, the NerveCenter Web Collector will automatically start.

To stop and start the NerveCenter Web Collector, you must use the Services Applet found in the Windows Control Panel. See your Windows documentation for more details on starting and stopping services.

Configuring a Web Server for NerveCenter

If NerveCenter web support was installed on a machine with a supported web server installed and running, NerveCenter Setup (or the installation script on UNIX) already configured your web server. Users should be able to connect immediately.

If NerveCenter web support was installed on a machine without an installed and running web server, you must configure your web server by doing the following:

1. Set up a NerveCenter directory that links to the Web subdirectory in the NerveCenter installation directory and that has read access.
2. Set up a NerveCenterCGI directory that links to the Web\CGI subdirectory in the NerveCenter installation directory and that has read and execute access.
3. Make sure that either index.html or default.htm are supported as default documents.

The following sections describe how to configure web servers to support the NerveCenter web client:

- ◆ *Configuring Internet Information Server*
- ◆ *Configuring an Apache Web Server*

Configuring Internet Information Server

The following sample procedure illustrates how to configure Internet Information Server (IIS) on Windows to support NerveCenter.

**NOTE**

See your web server documentation for complete instructions.

TO CONFIGURE INTERNET INFORMATION SERVER ON WINDOWS NT

1. Start the Internet Service Manager.
2. Select **Service Properties** for the server you chose when you installed NerveCenter.

**NOTE**

Any web server NerveCenter uses must use the default port 80.

3. Select the **Directories** tab.
4. Create the NerveCenter directory that links to the Web subdirectory by doing the following:
 - a. Select **Add**.
 - b. In the **Directory** field, type the full path of the Web subdirectory.
For example, if you installed in the default location, the path would be C:\Program Files\OpenService\NerveCenter\Web.
 - c. In the **Alias** field, type NerveCenter.
 - d. On the **Access** panel, select the **Read** check box.
 - e. Select **OK**.
5. Create the NerveCenterCGI directory that links to the Web\CGI subdirectory:
 - a. Select **Add**.
 - b. In the **Directory** field, type the full path of the Web subdirectory.
For example, if you installed in the default location, the path would be C:\Program Files\OpenService\NerveCenter\Web\CGI.
 - c. In the **Alias** field, type NerveCenterCGI.
 - d. On the **Access** panel, select the **Read** and **Execute** check boxes.
 - e. Select **OK**.

6. Check the **Enable Default Document** check box.
7. If the **Default Document(s)** field doesn't already include **index.html** and **default.htm**, add them. Separate multiple entries in this field with commas.
8. If Web publishing is off, turn on the web server.

On Windows 2000 and XP machines, IIS should be configured automatically when you select Web Support during installation. However, you should confirm that the settings are correct.

TO CONFIRM IIS IS CONFIGURED ON WINDOWS 2000 AND XP

1. Open the Internet Information Services dialog box by selecting **Start > Settings > Control Panel > Administration Tools > Internet Service Manager**.
2. On the **Tree** tab, expand the name of the server on which you installed NerveCenter Server.
3. Expand **Default Web Site** and select NerveCenter.
4. Select **Action > Properties**.
The NerveCenter Properties dialog box opens.
5. Confirm the following on the **Virtual Directory** tab:
 - a. The Local Path is C:\Program Files\OpenService\NerveCenter\Web, if you installed in the default location
 - b. The **Read** check box is selected.
 - c. **Scripts and Executables** is selected from the Execute Permissions list.
6. Click **OK** to close the NerveCenter Properties dialog box.
7. Repeat steps 3 and 4 this time selecting NerveCenterCGI.
8. Confirm the following on the **Virtual Directory** tab:
 - a. The Local Path is C:\Program Files\OpenService\NerveCenter\Web\CGI, if you installed in the default location
 - b. The **Read** check box is selected.
 - c. **Scripts and Executables** is selected from the Execute Permissions list.
9. Close the Internet Information Services dialog box.

If the NerveCenter and NerveCenterCGI directories were not created during installation, you can create them using the Virtual Directory Creation Wizard.

TO CREATE THE NERVECENTER AND NERVECENTERCGI DIRECTORIES ON WINDOWS

1. From the Internet Information Services dialog box, select **Default Web Site**.
For instructions on accessing the Internet Information Services dialog box, see *To confirm IIS is configured on Windows 2000 and XP on page 203*.
2. Select **Action > New > Virtual Directory**.
The Virtual Directory Creation Wizard opens.
3. Click **Next**.
The Virtual Directory Alias dialog box appears.
4. In the **Alias** field, enter NerveCenter and click **Next**.
The Web Site Content Directory dialog box appears.
5. In the **Directory** field, enter NerveCenter`InstallationPath`\Web and click **Next**.
The Access Permission dialog box appears.
6. Select the **Read** and **Execute** checkboxes and click **Next**.
7. Click **Finish**.
8. Repeat step 2 through step 7 to create a virtual directory named NerveCenterCGI with the Web Site Content Directory NerveCenter`InstallationPath`\Web\CGI.
You may also need to create virtual directories for the subdirectories in NerveCenter`InstallationPath`\Web (**Conf** and **Help**)



NOTE

If you have another web server running (Netscape FastTrack, for example), you must shut down the other web server before you can start IIS.

Configuring an Apache Web Server

To configure an Apache web server, you must edit the **httpd.conf** file as follows.

TO CONFIGURE AN APACHE WEB SERVER

1. Edit the file to use port 80.
2. Add the following lines (for UNIX, change C:\Program Files\OpenService\NerveCenter to /opt/OSInc):

```
Alias /NerveCenter/ "C:/Program Files/OpenService/NerveCenter/web/"

<Directory "C:/Program Files/OpenService/NerveCenter/web">
    Options Indexes FollowSymLinks MultiViews IncludesNoExec
    AddOutputFilter Includes html
    AllowOverride None
    Order allow,deny
    Allow from all
</Directory>

ScriptAlias /NerveCenterCGI/
"C:/ProgramFiles/OpenService/NerveCenter/web/cgi/"

<Directory "C:/Program Files/OpenService/NerveCenter/web/cgi">
    AllowOverride None
    Options None
    Order allow,deny
    Allow from all
</Directory>
```

By entering **http://server/NerveCenter** in a standard web browser, where server is the name of the machine on which your web server is running, users can now monitor a network.

The NerveCenter database does not require much maintenance, whether your database is a Microsoft SQL Server or Microsoft Access database on Windows or flat files on UNIX. You can view information about the database as well as statistics about the information it contains, back up and restore the database, and transfer the contents of one database to another.



NOTE

To install a new database, see the *Installing NerveCenter* book. You must be a Windows administrator or UNIX root to run SerializeDB.

This chapter includes the following sections:

Section	Description
<i>Database Formats on page 208</i>	Describes the NerveCenter database formats on each platform.
<i>Viewing Information about the Database on page 209</i>	Describes how to view information about the database, including the name of the data source, the name of the database, whether it is connected, and the number of each type of object it contains.
<i>NerveCenter Database Utilities on page 210</i>	Describes the NerveCenter database utilities SerializeDB and DBWizard.
<i>Backing up the Database on page 213</i>	Describes when and how to back up the contents of the database, using the SerializeDB application or running SerializeDB from the command line.
<i>Restoring the Database on page 217</i>	Describes when and how to restore the contents of the database, using the SerializeDB application or running SerializeDB from the command line.
<i>Transferring Data between Databases on page 221</i>	Describes how to transfer the contents of the database to another database—even a database on another platform or of a different type.
<i>ncdb2html.pl on page 222</i>	Describes how to use the ncdb2html.pl script to convert the NerveCenter database to HTML.

Section	Description
<i>Troubleshooting: Managing the NerveCenter Database on page 227</i>	Lists some of the common problems users face when working with the NerveCenter database.

Database Formats

NerveCenter supports three different database formats—use the most appropriate one for your environment. The three database formats are:

- ◆ Microsoft SQL Server (Windows)

You determine the Microsoft SQL Server database name when you install NerveCenter and run DBWizard to create the database. The database is located on the SQL server machine and the ODBC connection string on the NerveCenter server machine points to the database.

- ◆ Microsoft Access (Windows)

The name of the Microsoft Access database file is **NCAccess.mdb**. The file must be located on the server machine. (You do not have to have Microsoft Access installed on the server machine.)

- ◆ Flat files (UNIX)

The files that make up the UNIX database are **NerveCenter.ncdb**, which contains information about the NerveCenter objects such as polls and alarms, and **NerveCenter.node**, which contains information about nodes.



NOTE

In the past, the UNIX database was made up of the following files: ***.ncdb**, **alarm_sum.def**, **sysobjid.dat**, ***.ovhosts**, and ***.ncdb.nts**.

When NerveCenter was installed, the installer set up one of these databases. If you find another format or platform would be more appropriate, you can create a new database on that platform (as long as you have a server on that platform) and transfer your data from the old database to the new one. See *Installing NerveCenter* for instructions on creating a new database. Also see *Transferring Data between Databases on page 221* for instructions on transferring data from one database to another.

Viewing Information about the Database

From the NerveCenter Client or Administrator, you can find out the name of the data source, the machine on which the database is kept (if it is different from the machine on which the server runs), the name and location of the database, and whether the database is connected. You can also view the number of alarms, polls, nodes, masks, property groups, and properties stored in the database.

Information about the database is useful when you are troubleshooting or when you just want to verify the database information—for example, to make sure you are going to back up the contents of the correct database.

TO VIEW INFORMATION ABOUT THE DATABASE

1. If you are connected to more than one server from either the administrator or client, make sure the server for which you want the database information is the active server.
2. From the **Server** menu, select **Server Status**.

The Server Status window is displayed.

STRIDER:Server Status	
Connected NerveCenters Connected Clients Connected Administrators OpC Host	
Server License Database Node Source Inform Configuration	
Server Machine Name	strider
Server IP Address	10.52.174.10
Connection Port	32504
NerveCenter Inform Port	32505
Command Line Interface Port	32506
Time Started	08/14/2000 10:25:52
Discover Nodes From Traps	Filter
Process Traps From Unknown Nodes	False
Apply All Masks For Each Trap	False

3. Select the **Database** tab.

The Database tab is displayed.

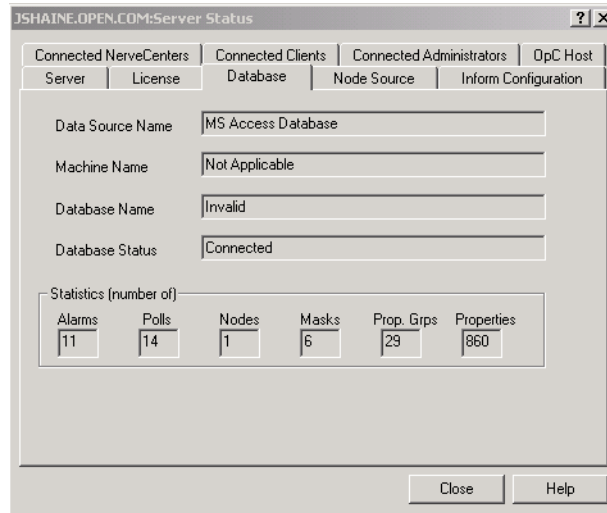

4. When you are done, select **Close** to close the Server Status window.

After you view the database information, you will know what database NerveCenter is using, whether the database is connected, and how many objects of each type are stored in the database.

NerveCenter Database Utilities

NerveCenter includes two utilities that facilitate data management.

Utility	Description
SerializeDB	A conversion utility that transfers NerveCenter data to and from a serialized file.
DBWizard	An installation and upgrade utility available only on Windows. DBWizard works with SerializeDB and InstallDB to install, upgrade, or connect to a Microsoft Access or SQL Server database.

NerveCenter uses different methods of storing information on UNIX and Windows systems. The following sections describe data management for each platform:

- ♦ [UNIX on page 211](#)
- ♦ [Windows on page 212](#)

UNIX

NerveCenter uses two files for data storage on UNIX:

- ◆ **NerveCenter.ncdb**—Contains information about NerveCenter objects, such as polls, masks, and alarms.
- ◆ **NerveCenter.node**—Contains information about the nodes that NerveCenter manages.

Both files are loaded into NerveCenter during installation. After installation, you can back up, restore, and transfer this data by using SerializeDB. *Figure 13-1* shows the UNIX database files.

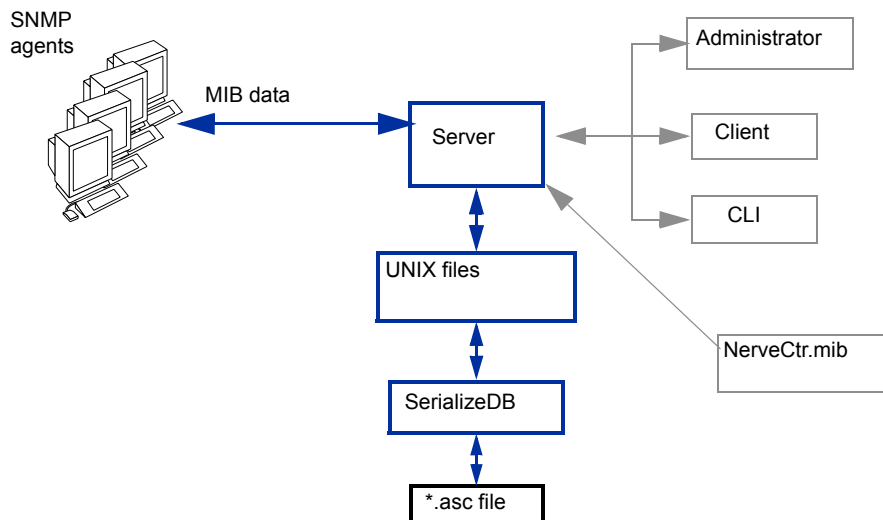

FIGURE 13-1. NerveCenter Data Storage Files on UNIX

SerializeDB performs two operations:

- ◆ Converts UNIX *.ncdb and *.node files to a single database file, whose name you provide at the time of conversion. The database file has a binary format with an .asc extension.
- ◆ Converts the same or another *.asc file to two *.ncdb and *.node files.

You can use the serialized file as a backup. Should you need to restore the backup, convert the file back to your original *.ncdb and *.node files. You can also transfer the serialized file to another NerveCenter machine and convert the file to *.ncdb and *.node files for that NerveCenter. Finally, you can transfer your original database files to a Windows NerveCenter and import the files. For more information about multiple NerveCenters, see *Using Multiple NerveCenter Servers on page 31*.

Windows

On Windows, NerveCenter stores behavior model objects in a database that is accessed using ODBC. *Figure 13-2* shows the Windows database files with the other NerveCenter components.

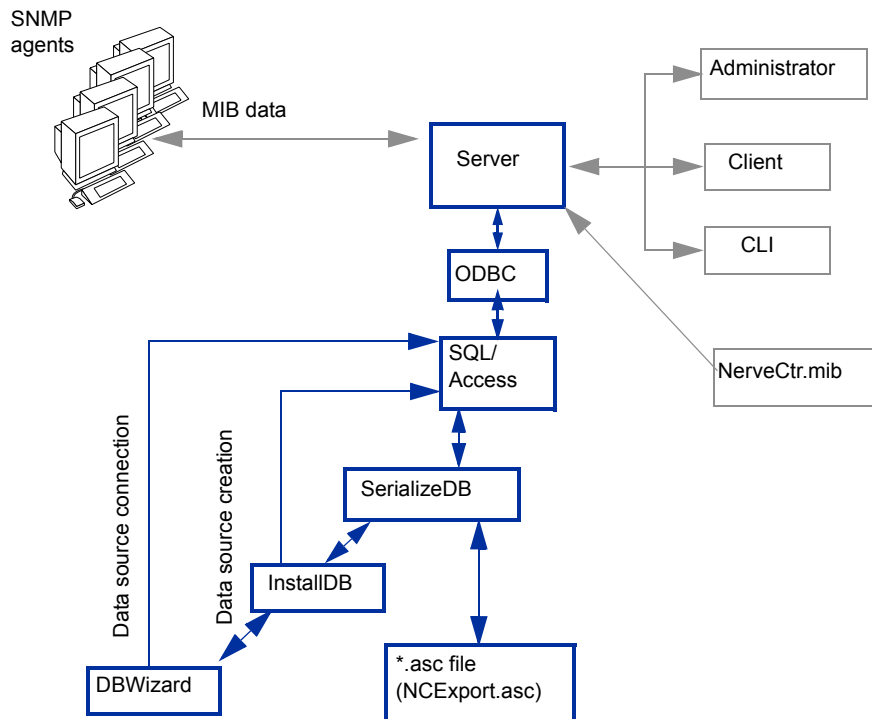

FIGURE 13-2. NerveCenter Database Components on Windows

NerveCenter ships with a serialized file that is imported into the database during installation. The file, `NCEExport.asc`, contains the base set of NerveCenter objects, such as polls, masks, and alarms. During installation, `DBWizard` allows you to enter settings, for example, an ODBC source and a SQL Server host. `DBWizard` invokes an installation tool called `InstallDB` to configure the SQL Server or Access database. `InstallDB`, in turn, invokes `SerializeDB` to convert `NCEExport.asc` to the proper database format. `InstallDB` can also be run standalone with `SerializeDB` to perform unattended database installations.

Afterward, if you upgrade to a new version of NerveCenter, `DBWizard` can be used to run an upgrade script against your database. Upgrade requirements for each new release are included in the *Release Notes* that accompany the release.

As with the UNIX environment, you can use SerializedDB to transfer data between your NerveCenter database and a serialized file. This lets you back up, restore, and transfer a database. On Windows, SerializedDB performs the following operations:

- ◆ Converts your database to a single database file. The database file has a binary format with an .asc extension.
- ◆ Converts an *.asc file to a database.
- ◆ Converts your database to NerveCenter flat files (*.ncdb and *.node), which can then be imported to another NerveCenter on a UNIX machine.
- ◆ Converts UNIX *.ncdb and *.node files to a SQL Server or Access database.

For information about working with multiple NerveCenters, see [Using Multiple NerveCenter Servers on page 31](#). You can also use DBWizard as an interface that runs SerializedDB and InstallDB to import a serialized file that you specify in DBWizard.

Backing up the Database

You should establish a regular database backup schedule that suits your environment. Also, you should back up your database prior to doing anything that might affect the database. For example, you'll want to back up the database before upgrading NerveCenter or before importing data from another database. Then, if you need to restore the original data, you can.

SerializedDB exports the object and node data from the database to a single serialized ASCII file (*.asc). On Windows, SerializedDB offers an alternative: exporting to a NerveCenter flat file database, which is made up of two text files (*.ncdb and *.node). The flat file database files can be used on UNIX or can be imported into a database on Windows.



NOTE

The NerveCenter Server checks its connection to its database server on a regular basis. If the connection has been broken, the NerveCenter Server attempts to reestablish it. Upon reestablishing the connection, the NerveCenter Server writes its current data to the database. The retry interval is two minutes.

If, when the NerveCenter Server exits gracefully, its connection to the database server is down, it saves its current database information to an .ASC file in the NerveCenter DB directory and logs a message in the event log. The format of the file is **MONTHDAYYEAR_HOURMINUTE.ASC**. You can then use SerializedDB to restore this data.

You can use any number of methods to set up regularly scheduled backups, depending on your environment. Select the method that fits in best with your existing backup strategy. Here are some suggestions:

- ◆ If you use a backup tool for scheduled backups already, use it to back up the NerveCenter database, too.
- ◆ If you use a scheduling tool, create a process to back up the NerveCenter database.
- ◆ If you have a Microsoft SQL Server database, use the SQL Server backup utilities to back up the database.
- ◆ On UNIX, set up a cron job to run `SerializeDB` (the backup utility that ships with NerveCenter) from the command line at a regular interval.

If you need to do a manual backup in addition to your scheduled backups, see [Backing up the Database on page 213](#).

**NOTE**

We recommend you use `SerializeDB` (application or command line) instead of manually copying the database file to another directory to make sure you back up the correct files and to minimize the size of the backup file.

`Serialize DB` exports the data in your database to a text file. When you use the `SerializeDB` GUI on Windows, you can choose the text file format—you can have `SerializeDB` export the data to a NerveCenter flat file database or a serialized ASCII file. You might want to export data from a database on Windows to a flat file database if you want to use the resulting file on a UNIX machine without having to import the data.

**CAUTION**

Before you back up the database, you must shut down the NerveCenter Server. Not shutting down the NerveCenter Server, could result in lost data.

If you are backing up a UNIX flat file database, all of the files that make up the database must be in the `db` directory. See [Database Formats on page 208](#) for more information.

TO BACK UP THE DATABASE USING THE SERIALIZEDB APPLICATION

1. Do one of the following to start SerializedB:
 - ♦ On Windows, start **SerializeDB** from the NerveCenter program group in the **Start** menu.
 - ♦ In a UNIX shell, change directories to the NerveCenter bin directory and type **./serializedb &**. Then press **Enter**.

The SerializedB window is displayed.

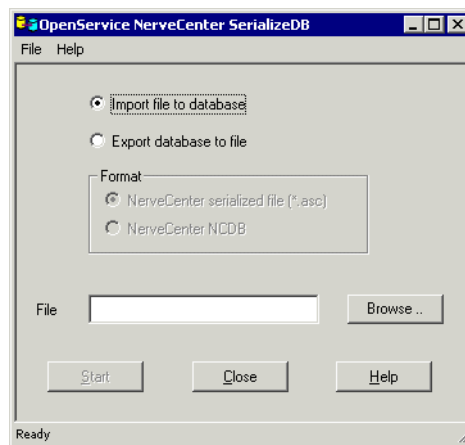

2. Select the **Export database to file** radio button.
3. Specify the format by selecting one of the following radio buttons:
 - ♦ NerveCenter **serialized file (*.asc)**
 - ♦ NerveCenter **NCDB (Windows only)**

**NOTE**

Unless you plan on using the resulting files directly with a UNIX server, we recommend you select the NerveCenter serialized file option. The ASC file is smaller, and because it is a single file, it is easier to manage.

4. Do one of the following:
 - ♦ To export the data to a new file, type a name for the file (for example, **backup061503**) in the **File** field. If you do not specify a path as part of the name, SerializedB creates the file in the NerveCenter db directory.

- ◆ To write over existing data, select the **Browse** button. Select the existing file. Then select **Open**.
5. Select **Start**.

On UNIX, SerializedDB starts exporting the data.

On Windows, you must specify the data source for the database. The Select Data Source window is displayed.

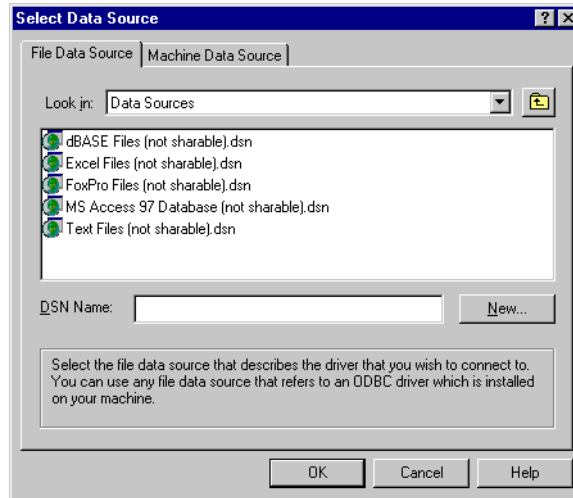

- Select the **Machine Data Source** tab.
- Select the data source for your NerveCenter database. Then select **OK**.

See your Microsoft ODBC documentation for more information about selecting data sources.

When the data has been exported, SerializedDB displays a message letting you know that the data transfer was successful.

When running SerializedDB from the command line, you can only export to a serialized file (.asc file).

Restoring the Database

If you have established a regular backup schedule and make sure you back up the database when you are doing anything that might affect the database (such as an upgrade), you'll be able to restore your data with minimal loss if you have a database problem. Here are some typical examples of situations when you'll want to restore the database:

- ◆ The machine on which the database is stored crashes. You install NerveCenter on another machine and restore your database.
- ◆ You import new behavior model objects, but discover they are causing some problems. You roll back the database so you can eliminate the problems while you troubleshoot the behavior models.
- ◆ To preserve the data in your Microsoft Access database during an upgrade, you back it up. After the upgrade, you restore your data and continue running NerveCenter.

For more information, see:

- ◆ [Restoring the Database Using the SerializeDB Application on page 217](#)
- ◆ [Restoring the Database from the Command Line on page 219](#)



NOTE

We recommend that you use SerializeDB (application or command line) instead of manually copying a backup to the db directory to make sure you import the data correctly and reestablish the connection to the database.

Restoring the Database Using the SerializeDB Application

SerializeDB imports the data in your database from a text file. When you use the SerializeDB GUI on Windows, you can have SerializeDB import the data from a NerveCenter flat file database or a serialized ASCII file.



CAUTION

Before you restore the database, you must shut down the NerveCenter Server. If you don't shut down the NerveCenter Server, you could lose data.

If you are restoring a UNIX flat file database, all of the files that make up the database must be in the db directory. See [Database Formats on page 208](#) for more information.

 TO RESTORE THE DATABASE USING THE SERIALIZEDB APPLICATION

- Do one of the following to start SerializedB:
 - On Windows, start **SerializeDB** from the NerveCenter program group in the **Start** menu.
 - In a UNIX shell, change directories to the NerveCenter bin directory and type **./serializedb &**. Then press **Enter**.

The SerializedB window is displayed.

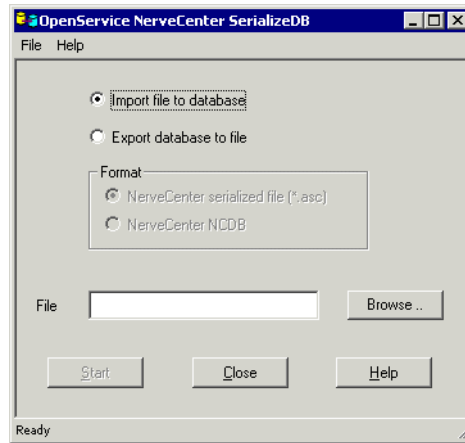

- Select the **Import file to database** radio button.

The Format radio buttons are not available because they do not apply to importing data.

- In the File field, specify the ***.asc** (UNIX and Windows) or ***.ncdb** file (Windows) from which you want to import data.

You can also use the **Browse** button to select a file. In the Select File dialog box, select the file; then select **Open**.



NOTE

If you select an ***.ncdb** file, the file must not have more than one period (.) in the name—NerveCenter.old.ncdb, for example, would not work.

- Select **Start**.

On UNIX, SerializedB starts importing the data.

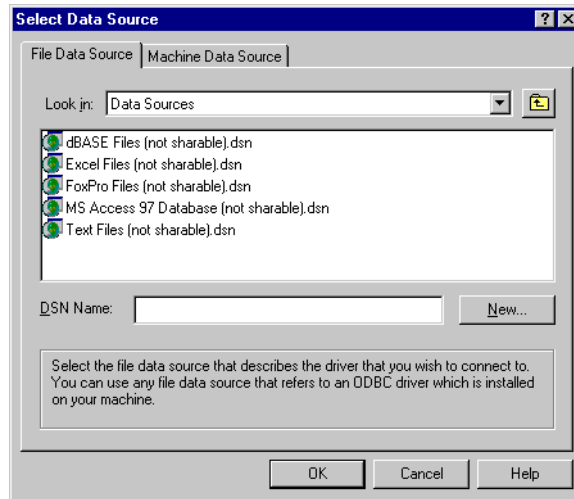
On Windows, you must specify the data source for the database. The Select Data Source window is displayed.



- a. Select the **Machine Data Source** tab.
- b. Select the data source for your NerveCenter database. Then select **OK**.

When the data has been imported, SerializedDB displays a message letting you know that the data transfer was successful.

Restoring the Database from the Command Line

When you run SerializedDB from the command line, SerializedDB imports the data into your database from a serialized ASCII file. You can issue SerializedDB commands from a script. For example, on UNIX, you can write a script called `restorencdb` that shuts down the server, imports the data from `backup.asc`, and restarts the server.

CAUTION

Before you restore the database, you must shut down the NerveCenter Server. If you don't shut down the NerveCenter Server, you could lose data.

If you are restoring a UNIX flat file database, all of the files that make up the database must be in the `db` directory. See [Database Formats on page 208](#) for more information.

 TO RESTORE THE DATABASE USING THE COMMAND LINE

1. Enter one of the following:

- ◆ At a DOS prompt:

```
serializedb -F backupfile.asc -O FileToDB -R
```

or

```
serializedb -F backupfile.asc -O FileToDB -C
"DSN=datasourcename;UID=userID;PWD=password"
```

Replace *backupfile.asc* with the name of the file you want SerializeDB to import. If your current working directory is not the directory in which *backupfile.asc* is located, specify the path with the name of the file.

- ◆ Use **-R** to have SerializeDB get the data source name, user ID, and password from the registry. You can use **-R** with a Microsoft SQL Server database or a Microsoft Access database.
- ◆ Use **-C** "**DSN=datasourcename;UID=userID;PWD=password**" instead of **-R** only if you are restoring a Microsoft SQL Server database. Replace *datasourcename* with the existing data source name, *userID* with the appropriate SQL Server user ID, and *password* with the corresponding password.
- ◆ In a UNIX shell:

CAUTION

On UNIX, SerializeDB requires an Xdisplay even when running in command line mode. Therefore, do not run SerializeDB remotely or on a headless server via a TTY.

```
serializedb -F backupfile.asc -O FileToDB -R -D NerveCenter.ncdb
```

Replace *backupfile.asc* with the name of the file you want SerializeDB to import. If your current working directory is not the directory in which *backupfile.asc* is located, specify the path with the name of the file.

NOTE

The ***.ncdb** file must not have more than one period (.) in the name—NerveCenter.old.ncdb, for example, would not work.

2. Check to make sure the data was imported.

**TIP**

Use the timestamp and the size of the file as an indicator of success. For example, if the timestamp is old or the file size is 0K, you need to investigate further.

If the SerializeDB does not import the data successfully, check the Event Log on Windows or the system log on UNIX for error messages.

Transferring Data between Databases

You can transfer data between databases on different platforms, between databases that have different formats, or both.

**CAUTION**

Remember, before doing anything that affects your database, including transferring data between databases, shut down the NerveCenter Server and back up the database.

To transfer data, you'll need to know how to:

- ◆ Export, or back up, data (*Backing up the Database on page 213*)
- ◆ Import, or restore, data (*Restoring the Database on page 217*)

**CAUTION**

Note to MS-Access Database Users

You must serialize your database before installing NerveCenter 3.8. You cannot use the NerveCenter 3.8 version of SerializeDB to serialize older databases.

If you did not serialize your old database, you must re-install your old version of NerveCenter and serialize your database.

To serialize a NerveCenter 3.8 database after installing NerveCenter 3.8, run SerializeDB.exe using NCAccess.mdb as the database to produce a new .asc file.

ncdb2html.pl

Included in NerveCenter 3.8 is a utility that will convert *.ncdb and *.node files to HTML, so that you can easily know what NerveCenter objects are in your database.

The screenshot displays the output of the ncdb2html.pl utility. At the top, there is a header for 'Open service' with the tagline 'Proven network and security threat management'. Below this is a navigation menu with links for SOLUTIONS, PRODUCTS, EVALUATION, NEWS, PARTNERS, ABOUT US, SUPPORT, and CONTACT. The main content area shows 'NerveCenter AutoDoc v0.5.6 beta' on the left, 'NerveCenter Database' in the center, and 'Tue Oct 22 13:05:14 2002' on the right. An 'Index' link is centered below the header. A 'Main Page:' section lists various object categories with counts: Nodes (1), Alarms (15), PERL Subroutines (1), Triggers (49), Poll Conditions (14), TRAP Masks (6), Properties (1236), Property Groups (29), Severities (13), and OidToGroup (311). A 'Jump To:' section provides direct links to Alarms, PERL Subroutines, Triggers, Poll Conditions, TRAP Masks, Properties, Property Groups, Severities, and OidToGroup. Three main sections are highlighted with bold text: 'Alarms:', 'PERL Subroutines:', and 'TRAP Masks:'. Each section contains a list of object names in a grid format. The 'Alarms' section lists 15 items, 'PERL Subroutines' lists 1 item, and 'TRAP Masks' lists 4 items. Below these, the 'POLL Conditions:' section lists 14 items in a grid format.

Alarms:

- AllTraps_LogToFile
- IfErrorStatus
- SnmpStatus
- xCorr_Error
- Authentication
- IfLinkUpDown
- TopConnMon
- xCorr_Test
- ErrorRate
- IfLoad
- TcpRetransAlg
- xCorr_Test2
- IcmpStatus
- IfUpDownStatus
- TcpRetransMon

PERL Subroutines:

- SS_IcmpError

TRAP Masks:

- AllTraps
- LinkUp
- AuthFail
- WarmStart
- ColdStart
- LinkDown

POLL Conditions:

- AuthFail
- IfErrorRates
- SnmpFastPoll
- TcpRetransStatus
- AuthQuickFail
- IfLoadRates
- SnmpPoll
- ifStatus
- IS_IcmpFastPoll
- SS_IcmpFastPoll
- TcpConnectionMon
- IS_IcmpPoll
- SS_IcmpPoll
- TcpRetransAlg

FIGURE 13-3. Sample ncdb2html.pl Output

Table 13-1 details the contents of the HTML output:

TABLE 13-1. Output of ncdb2html.pl

File	Contents
ncindex.html	<p>Summarizes the contents of your database. Provides links to all other pages. Contains the following categories:</p> <ul style="list-style-type: none">◆ Alarms◆ Perl subroutines◆ Trap masks◆ Poll conditions◆ Triggers◆ Properties◆ Property Groups◆ Severities◆ Oid to Group
nodes.html	<p>Details each alarm in your database, including the following information:</p> <ul style="list-style-type: none">◆ Node Name◆ Node Properties<ul style="list-style-type: none">◆ Status◆ Property Group◆ Suppressible◆ Auto Delete◆ SNMP Properties<ul style="list-style-type: none">◆ Read-Only Community◆ Read-Write Community◆ Port◆ SNMP Version◆ Address List

TABLE 13-1. Output of `ncdb2html.pl` (Continued)

File	Contents
alarms.html	Details each alarm in your database, including the following information: <ul style="list-style-type: none"> ◆ Status ◆ Scope ◆ Property ◆ Notes ◆ State and transition summary
perlsub.html	Lists all Perl subroutines in your database.
triggers.html	Lists all triggers in your database, including the following information: <ul style="list-style-type: none"> ◆ Trigger name ◆ Trigger type ◆ Where trigger is fired from
polls.html	Details each poll in your database, including the following information: <ul style="list-style-type: none"> ◆ Status ◆ Property ◆ Base Object ◆ Frequency ◆ Suppressible ◆ Notes ◆ Poll Condition
masks.html	Details each trap mask in your database, including the following information: <ul style="list-style-type: none"> ◆ Status ◆ Generic trap value ◆ Vendor specific trap number ◆ Enterprise filter (From/From Only) ◆ Simple trigger ◆ Notes ◆ Mask function

TABLE 13-1. Output of ncdb2html.pl (Continued)

File	Contents
property.html	Lists all properties defined in your database and the property groups they belong to.
propertygrp.html	Lists all property groups in your database and all properties included in each group
severities.html	Details each severity defined in your database, including the following information: <ul style="list-style-type: none"> ◆ Severity Name ◆ Color ◆ group ◆ level ◆ platform_level ◆ platform_name
oidtogroup.html	Lists all OIDs in your database and the MIB module the OID belongs to.

The *.ncdb and *.node files are the database format on UNIX systems. To convert Access or SQL NerveCenter databases, use the SerializeDB utility. For more information about SerializeDB, see [NerveCenter Database Utilities on page 210](#) or the SerializeDB help.

TO CONVERT *.NCDB AND *.NODE TO HTML



NOTE

This script requires Perl 5.6.0 or greater to execute.

1. From a command line or UNIX prompt, navigate to the *installation/Samples/ncdb2html* directory.
2. Type the following command:

```
ncdb2html.pl -ncdb=path/filename.ncdb
             -node=path/filename.node -h      -dir=output_directory
```

The options for this script are detailed in [Table 13-2](#):

TABLE 13-2. `ncdb2html.pl` Options

Option	Description
<code>-ncdb=<i>ncdb_file</i></code>	Required. Specify the location of <code>ncdb</code> file (<code>./NerveCenter.ncdb</code> is default)
<code>-node=<i>node_file</i></code>	Optional. Specify the location of the node file (no default)
<code>-dir=<i>output_directory</i></code>	Specify the directory to place the HTML files (current directory is the default)
<code>-title=<i>title</i></code>	Specify a title for the top of each page (no default)
<code>-h</code>	Hide the community strings on the node page
<code>-sh</code>	Suppress the Open header at the top of each page
<code>-usage</code>	Display usage information and exit

Troubleshooting: Managing the NerveCenter Database

The following list contains some common database problems that users encounter.

The server shut down gracefully, but event log said that the database was not found. Where did the updates to the database go?

Problem: The database was not available (if, for example, the network connection between the NerveCenter server and the SQL database went down) so NerveCenter couldn't write the changes to the database.

Solution: NerveCenter serializes the database information if the database is not available. The file is `date_time.asc` in the `db` directory. While the server is still shut down, import the contents of the file when the database is available again. See [Restoring the Database on page 217](#).

Running SerializedDB from the command line keeps failing

Problem: The paths to your databases or the serialized files are not specified correctly.

Solution: If you are not in the `db` directory, make sure you include the paths in the command line options where appropriate. See [Backing up the Database on page 213](#) or [Restoring the Database from the Command Line on page 219](#).

SerializeDB won't work from the application or the command line

Problem: You must be an Administrator or root to run `SerializeDB`.

Solution: Make sure you are logged in correctly. See [Managing the Database on page 207](#).

The data in the database is not what was imported from the serialized file

Problem: The server was running when you imported the file. The server overwrote the data you imported when it saved its changes to the database.

Solution: When you import or export data, make sure the server is not running. If it was, you must shut it down and reimport or export the data. See [Backing up the Database on page 213](#) or [Restoring the Database on page 217](#).

Managing Management Information Bases (MIBs)

By modifying the OpenService NerveCenter MIB, you control which devices NerveCenter can effectively manage. The major SNMP MIB definitions and OpenService management application MIB definitions are already compiled in the default NerveCenter MIB. You can add other standard MIB definitions and vendors' MIB definitions—many of which are shipped with NerveCenter—as you need them.

This chapter includes the following sections:

Section	Description
<i>Sources of MIB Definitions on page 230</i>	Describes the definitions that are pre-compiled in the NerveCenter MIB, the vendor definitions that are shipped with NerveCenter, and guidelines for using definitions from other sources.
<i>Adding or Removing MIB Definitions on page 232</i>	Describes how to add and remove references to MIB definitions from a text file that determines which MIB definitions are compiled into the NerveCenter MIB.
<i>Compiling the NerveCenter MIB on page 235</i>	Describes how to use the MIB compiler to compile the NerveCenter MIB.
<i>Configuring NerveCenter to Use the New MIB on page 237</i>	Describes how to use the NerveCenter Administrator to load the MIB.
<i>Troubleshooting: Managing MIBs on page 239</i>	Lists common problems users face when using MIBs.

Sources of MIB Definitions

Several MIB definitions—the OpenService management application definitions and the major Internet standard SNMP definitions—are already compiled into `nervectr.mib`, the MIB that is installed with NerveCenter.

MIB definitions from other vendors (for Cisco router support, for example) are shipped with NerveCenter. These definitions are not pre-compiled into the NerveCenter MIB because incorporating all the definitions would increase the size of the MIB and could affect performance unnecessarily. You may add the definitions that are appropriate for your environment.

You can also add MIB definitions you've gotten from other sources.

For more information, see:

- ◆ *Definitions Compiled into the NerveCenter MIB on page 230*
- ◆ *Definitions Not Compiled into the NerveCenter MIB on page 231*
- ◆ *Definitions from other sources on page 232*

Definitions Compiled into the NerveCenter MIB

The definitions that are already compiled into the NerveCenter MIB are the OpenService management application definitions and the major Internet standard SNMP definitions. The definitions are in subdirectories in the `mib` directory (`mibs` on UNIX).

Table 14-1 lists the subdirectories that contain these definitions and includes descriptions of each.

TABLE 14-1. Definitions Compiled into the MIB

This directory...	Includes definitions for...
<code>nsmg</code>	OpenService management applications
<code>standard-v1</code>	Internet standard RFC SNMPv1 MIB definitions (converted to SNMPv2 compliance)
<code>standard-v2</code>	Internet standard RFC SNMPv2 MIB definitions
<code>standard-v3</code>	Internet standard RFC SNMPv3 MIB definitions

Definitions Not Compiled into the NerveCenter MIB

Based on your environment, you decide which vendor definitions to compile into the NerveCenter MIB. The definitions are in subdirectories in the `mib\vendors` directory (`mibs\vendors` on UNIX).

The following table lists the vendor subdirectories that contain these definitions and includes descriptions to help you decide which ones you need.

TABLE 14-2. Definitions Not Compiled into MIB

This directory...	Includes definitions for...
3com	ECS Ethernet hubs
att	Smarthub product line
baynetworks	System 3000/5000 concentrators, Linkswitch Ethernet switches, and ATM Ethercell switches
chipcom	Networking product line
cisco	Router support of IOS 9.x, 10.x, and 11.x
compaq	Server, storage, and UPS systems
dec	DIGITAL ELAN networking devices
epix	ExpressLink product line
fibermux	Crossbow product line
hp	HP-UX servers using the HP-UX SNMP agent
microsoft	Servers and Internet Servers
nat	Network probes
ods	Ethernet and FDDI devices
retix	Remote bridge and router product lines
sun	UNIX SNMP agents
ungermanbass	Access/One and Ethernet concentrator products
wellfleet	Router support of 6.x/7.x SNMP agents
xyplex	Terminal servers

Definitions from other sources

You might want to add other MIB definitions to manage devices that are not supported by the MIBs shipped with NerveCenter. You can add MIB definitions from other sources as long as each one:

- ♦ Is a complete ASN.1 module definition that conforms to the standards specifications in RFC1902, *Structure of Management Information for Version 2 of the Simple Network Management Protocol (SNMPv2)*, RFC1903, *Textual Conventions for Version 2 of the Simple Network Management Protocol (SNMPv2)*, and RFC1904, *Conformance Statements for Version 2 of the Simple Network Management Protocol (SNMPv2)*. You can find these RFCs and others on the Web.



CAUTION

Before NerveCenter can compile a mib it must conform to the ASN.1 module definition standard. See the section [Troubleshooting ASN.1 files on page 283](#).

- ♦ Does not have the same name as a MIB definition already compiled into your NerveCenter MIB.

Also, remember that your devices must run SNMP agents from your vendor that support the new MIB definitions.

We recommend that you store additional definitions in the `mib\user` directory (you can create a user directory in the `mibs` directory on UNIX). Then, when you install a new version of NerveCenter, you can make a copy of this directory to preserve your additional third-party MIBs.

Adding or Removing MIB Definitions

The MIB compiler (`mibcomp`) compiles the MIB definitions referenced in a text file. You can add references to or remove them from this file to control what definitions are compiled into the NerveCenter MIB.

Add MIB definitions if you want to monitor additional devices. Remove MIB definitions if you are no longer monitoring the devices supported by those definitions. (Removing the definitions is not required; however, the NerveCenter MIB will be smaller, which can improve client performance and will make managing the MIB easier.)

If you are using NerveCenter with a network management platform and both applications are monitoring the same agents, make sure both applications are using the correct MIBs for those agents.

See [Sources of MIB Definitions on page 230](#) for a list of MIB definitions that are shipped with NerveCenter and what standards MIB definitions are not shipped with NerveCenter must follow.

**NOTE**

NerveCenter installs the file `nervectr38.mib` and `mibcomp38.txt`. These are copies of the default `nervectr.mib` and `mibcomp.txt` in case you need to revert to an unchanged MIB definitions.

The MIB compiler (`mibcomp`) compiles the MIB definitions referenced in a text file. You can add references to this file to control what definitions are compiled into the NerveCenter MIB.

**CAUTION**

If a MIB module depends on information in another MIB module you must reference it before the module that requires the information in `mibcomp.txt`. That is, if `mymibA` depends on `mymibB`, you must include `mymibB` before `mymibA` in `mibcomp.txt`.

If dependant MIB module references are out of order, you receive an error similar to the following:

```
8: standard-v2/rfc1573b.asn1 mgrtool.exe: process_data(), Couldn't
find parent: interfaces
mibcomp: unable to compile and resolve standard-v2/rfc1573b.asn1
```

In this example, `rfc1573b.asn1` depends upon another mib to define *interfaces*. You must find the mib that defines *interfaces* and include it before `rfc1573b.asn1` in `mibcomp.txt`. To find a MIB that defines *interfaces*, you search the other MIB modules looking for the following:

```
interfacesOBJECT IDENTIFIER ::= { mib-2 2 }
```

Now you can name the file that contains this line, in this case `rfc1213.asn1`, before `rfc1573b.asn1`.

**CAUTION**

All SMIV1 compliant MIB modules must be included in `mibcomp.txt` before the line
`#* * * End of SMIV1 / SNMPv1 MIB Modules * * *`
 All SMIV2 compliant MIB modules must be referenced after this line.

You can tell the difference between a SMIV1 module and an SMIV2 module by searching the `*.asn1` file for “MAX-ACCESS.

Sample SMIv1 SysUpTime definition	Sample SMIv2 SysUpTime definition
sysUpTime OBJECT-TYPE	sysUpTime OBJECT-TYPE
SYNTAXTimeTicks	SYNTAXTimeTicks
ACCESS read-only	MAX-ACCESS read-only
STATUS mandatory	STATUS current
DESCRIPTION	DESCRIPTION
“The time (in hundredths of a second) since the network management portion of the system was last re-initialized.”	“The time (in hundredths of a second) since the network management portion of the system was last re-initialized.”
::= { system 3 }	::= { system 3 }

Any use of ACCESS within a *.asn1 named in the SMIv2 area of mibcomp.txt causes an error. Any use of MAX-ACCESS within a *.asn1 named in the SMIv1 area of mibcomp.txt causes an error.

TO MODIFY THE MIBCOMP TEXT FILE

1. If you previously modified **mibcomp.txt** or **nervectr.mib**, make back-up copies of them in case you want to recover your changes.



NOTE

You can modify these files directly; they will not be overwritten during the next installation.

2. In a text editor, open the file.
3. To add definitions, do one of the following:
 - ◆ Remove the pound sign (#) in front of definitions that are currently commented out.
 - ◆ Add lines for new definitions. Include the directory and the name of the file. For example:

```
users/companyXYZ.asn1
```



NOTE

On Windows, use backslashes. On UNIX, you must use slashes.

4. To remove definitions, do one of the following:
 - ◆ Comment out definitions by adding a pound sign (#) in front of the appropriate lines. For example:

```
# xyplex
#
# vendors/xyplex/xyplex.asn1
```

- ◆ Delete the appropriate lines.

5. Save and close the file.

You have updated the file that includes references to the MIB definitions you need. Now, you must compile the NerveCenter MIB using the file you just created. See [Compiling the NerveCenter MIB on page 235](#).

Compiling the NerveCenter MIB

After you modify the `mibcomp.txt` file, you must compile the NerveCenter MIB. The MIB compiler updates the MIB to support the types of devices you want to monitor.

TO COMPILE THE MIB

1. At a command prompt, change to the `mib` directory (`mibs` on UNIX).
2. Type the following command. Then press **Enter**.

```
..\bin\mibcomp mibcomp.txt
```



NOTE

Use slashes, instead of backslashes, on UNIX.



TIP

You can use the `-trace` option to monitor the process of compiling your MIB.

The syntax is `..\bin\mibcomp -trace mibcomp.txt`.



CAUTION

If you have removed files from `mibcomp.txt`, you must run `mibcomp` with the `-clean` argument. For example:

```
../bin/mibcomp -clean mibcomp.txt.
```

For more information about using `mibcomp`, see [mibcomp on page 310](#).

If you have used previous versions of NerveCenter, please note that you do not need the `@`.

As the compiler compiles the file, it displays a series of messages. If a problem needs your attention, the compilation fails. You must resolve the error and re-compile. The error is displayed on the last line on your screen. You will have to do this more than once if you have several errors. Errors are generally syntax problems in third-party MIBs or MIBs that do not comply with the RFC specification. For tips on solving compilation errors, see [Troubleshooting: Managing MIBs on page 239](#).

3. If you did not compile the MIB on the machine that is running the NerveCenter Server, copy it to the server machine now.

**CAUTION**

The MIB must be located locally on the machine hosting NerveCenter Server. Configure security on the server machine appropriately so no unauthorized users can overwrite or change the MIB. On UNIX, set permissions to read-only using the following command: `chmod 444 nervectr.mib`. On Windows, make the .mib file read-only or set its directory permission to read-only.

You have updated the MIB that includes the definitions you need. Now, you must use the NerveCenter Administrator to load this MIB. See [Configuring NerveCenter to Use the New MIB on page 237](#).

Configuring NerveCenter to Use the New MIB

After you have compiled the NerveCenter MIB, you must reload it. From the Administrator, you can specify the name and location if you created a new MIB file and then load the file.



NOTE

You must be a member of NerveCenter Admins on Windows or a member of ncadmins on UNIX.

TO LOAD THE NEW MIB

1. From the Administrator, connect to the server.
2. Select the **Server** tab.

NerveCenter displays the Server tab.

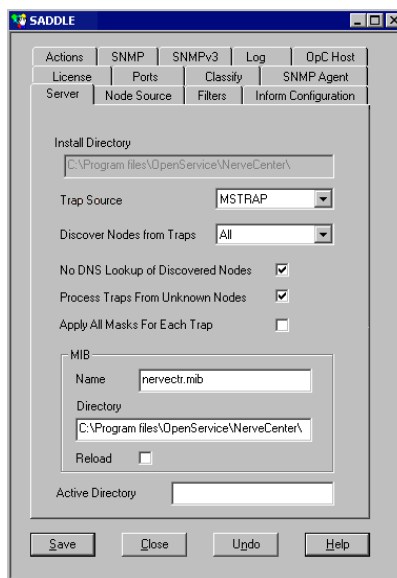

3. If the name of the MIB has changed, type the name of the new NerveCenter MIB in the **Name** field.
4. If the location of the MIB has changed, type the new path in the **Directory** field.
5. Check the **Reload** check box.

6. Select **Save**.

NerveCenter displays a message that tells you the data was saved successfully. Clients that are connected to this server automatically receive the updated MIB information and display a message to users.

**CAUTION**

Any clients that are currently connected to this server and have the Share MIB check box selected are updated to use the new MIB, even if they were sharing a MIB from another server.

7. If you want other NerveCenter Servers to use this MIB, repeat this procedure for each NerveCenter Server.
-

You have specified and loaded the new MIB. If your network management platform uses the NerveCenter MIB, you'll need to update that information in your network management platform. See the documentation for your network management platform for details.

If you added new definitions, you may want to create new property groups that contain properties for the new MIB base objects. See *Defining Property Groups and Properties in Designing and Managing Behavior Models*.

Troubleshooting: Managing MIBs

The following list contains some common problems that users may encounter when updating the NerveCenter MIBs.

As mentioned in *Adding or Removing MIB Definitions on page 232*, MIB modules are dependant on information in other MIB modules. Although a MIB module may compile by itself, there may be problems with dependencies with other MIB modules. This section gives suggestions on how to solve compilation errors.

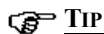
**TIP**

If MibComp finds a dependency or definition error, it will repeat the error for each MIB module encountered. To find where the problem begins, run MibComp with the **-clean** and **-trace** arguments and note when the problem first occurs.

A MIB won't compile

Problem: The vendor ASN1 definitions that you added are not formatted correctly.

Solution: Check for spelling and format.

See *Troubleshooting ASN.1 files on page 283*.

Problem: The mibcomp.txt file is not formatted correctly.

Solution: Check to make sure the appropriate lines are included in the file and not commented out.

See *Adding or Removing MIB Definitions on page 232*.

Problem: The ASN1 file does not exist in the directory referenced in the mibcomp.txt file.

Solution: Move the file to the specified directory or correct the path in the mibcomp.txt file.

Problem: You must run the command from the mib directory (mibs on UNIX).

Solution: Change to the correct directory and run the mibcomp command again.

See *Compiling the NerveCenter MIB on page 235*.

Problem: User or file permissions are not set correctly, so mibcomp cannot create or update the MIB file.

Solution: Check user or file permissions and correct them, if necessary. See your operating system documentation.

Problem: Redefinitions of MIB entity enumerations across SNMPv1, v2c, and v3.

Example: WARNING: enumeration conflicts during merge for ifType (continuing)

Solution: These warnings can be safely ignored. Some values, such as `ifType` or `ifOperStatus`, have been redefined for different SNMP versions.

Problem: More than one MIB module has defined entities with the same name.

Example: `/opt/OSInc/bin/mgrtool: check_names: Duplicate name with different OIDs: ds1 OID1: 1.3.6.1.2.1.10.18, OID2: 1.3.6.1.3.2 continuing (since -i option was used)`

Solution: First, find which MIB modules are defining the duplicated name. When `MibComp` finds a second definition, it creates an error message similar to the above example. Next, you must research the MIB modules to see if either module has been replaced with a compliant MIB module.

Problem: A MIB module depends upon a definition from another MIB module.

Example: `find_type(): unknown type: SnmpAdminString`
`mibcomp: unable to compile and resolve standard-v3/v3-tgt.my`

Solution: Look at the `IMPORTS` clause of the module that produced the error. In the example, `v3-tgt.my` declares that `SnmpAdminString` is to be imported from `SNMP-FRAMEWORK-MIB`. A search of the modules shows that `SNMP-FRAMEWORK-MIB` is defined in `v3-arch.my`. Therefore, you must name `v3-arch.my` before `v3-tgt.my`.

Problem: More than one MIB module provides a name for an OID.

Example: `/opt/OSInc/bin/mgrtool: Warning: Duplicate OIDs with different names.`
The first name will appear before the second name.
OID: 1.3.1.4.1.9.7.99999.2, First name: `cwRsrcPartCapabilityRpmV2R0160`,
Second name: `ciscoWanModuleCapabilityV2R00`

Solution: Often this is not a problem but should be investigated. In the example, two different Cisco MIB modules state two different names for the same OID. Which device and version of IOS is encountered at run-time will likely resolve which way the OID will be handled. Check which devices you are currently running and whether you need to have the MIB modules with the duplicate names `mibcomp.txt`. A review of your Cisco devices may show that the MIB module that names the first occurrence is not needed.

A MIB won't load

Problem: You must be a member of `ncadmins` on UNIX or `NerveCenter Admins` on Windows to load a MIB.

Solution: Make sure you have appropriate group membership.

Configuring NerveCenter to Use the New MIB on page 237.

Problem: The MIB must be located on the server machine.

Solution: Copy the MIB to the server machine and try loading it again.

See *Compiling the NerveCenter MIB on page 235*.

Problem: The name or location of the MIB has changed.

Solution: Update the name and location of the MIB and try loading it again.

See *Configuring NerveCenter to Use the New MIB on page 237*.

Error Messages

A

This appendix explains the error and information messages that you might encounter while using NerveCenter. Possible causes and solutions for the errors are included.

This appendix includes the following sections:

Section	Description
<i>User Interface Messages on page 243</i>	Explains where error messages appear as well as the different types of error messages.
<i>Error Messages on page 245</i>	Lists the error messages and possible solutions.

User Interface Messages

All NerveCenter error messages are written to the Event Log. To view messages in the Event Log:

- ◆ In Windows: Run the Event Viewer and display the Application log. Each error message is listed as a line in the log.
- ◆ In UNIX: Read the ASCII file `/var/adm/messages` with a text editor or a command such as “more.”

Each error description is formatted in the following way:

```
Category error_message_number: message: [code_number]
```

Each message is assigned a category, which has a corresponding number. The line listed in the log uses a number to indicate a category, as follows:

TABLE A-1. Error Message Categories

Number	Category
1	NC Server Manager
2	NC Alarm Manager
3	NC Trap Manager

TABLE A-1. Error Message Categories (Continued)

Number	Category
4	NC Poll Manager
5	NC Action Manager
6	NC Protocol Manager
7	NC PA Resync Manager
8	NC Service
9	NC Inform NerveCenter Manager
10	NC OpC Manager
11	NC LogToFile Manager
12	NC FlatFile Manager
13	NC Alarm Filter Manager
14	NC Deserialize Manager
15	NC LogtoDB Manager
16	NC DB Manager
17	NC Inform OV

The error message number indicates the type of error. The error message numbers are organized as follows:

TABLE A-2. Error Message Numbers

Number Range	Type of Error
0-999	Users should call customer support.
1000-1999	User can resolve the problem.
2000-2999	User is warned of an event.
3000-3999	User is given an informational message.

The error messages are explained in the following sections:

- ◆ *Action Manager Error Messages on page 246*
- ◆ *Alarm Filter Manager Error Messages on page 251*
- ◆ *Deserialize Manager Error Messages on page 251*

- ◆ *Flatfile Error Messages on page 252*
- ◆ *Inform NerveCenter Error Messages on page 252*
- ◆ *Inform OV Error Messages on page 252*
- ◆ *LogToDatabase Manager Error Messages on page 255*
- ◆ *LogToFile Manager Error Messages on page 256*
- ◆ *OpC Manager Error Messages on page 256*
- ◆ *Poll Manager Error Messages on page 257*
- ◆ *Protocol Manager Error Messages on page 257*
- ◆ *PA Resync Manager Error Messages on page 258*
- ◆ *Server Manager Error Messages on page 260*
- ◆ *Trap Manager Error Messages on page 265*
- ◆ *NerveCenter installation Error Messages (UNIX) on page 266*
- ◆ *OpenView Configuration Error Messages (UNIX) on page 269*

Error Messages

The following tables list particular error messages that may occur when operating NerveCenter. For an explanation of what types of error messages exist and where error messages appear, see the section *User Interface Messages on page 243*.

The messages include:

- ◆ *Action Manager Error Messages on page 246*
- ◆ *Alarm Filter Manager Error Messages on page 251*
- ◆ *Deserialize Manager Error Messages on page 251*
- ◆ *Flatfile Error Messages on page 252*
- ◆ *Inform NerveCenter Error Messages on page 252*
- ◆ *Inform OV Error Messages on page 252*
- ◆ *LogToDatabase Manager Error Messages on page 255*
- ◆ *LogToFile Manager Error Messages on page 256*
- ◆ *OpC Manager Error Messages on page 256*

- ◆ *Poll Manager Error Messages on page 257*
- ◆ *Protocol Manager Error Messages on page 257*
- ◆ *PA Resync Manager Error Messages on page 258*
- ◆ *Server Manager Error Messages on page 260*
- ◆ *Trap Manager Error Messages on page 265*
- ◆ *NerveCenter installation Error Messages (UNIX) on page 266*
- ◆ *OpenView Configuration Error Messages (UNIX) on page 269*

Action Manager Error Messages

Following is a list of Action Manager error messages.

TABLE A-3. Action Manager Error Messages

Error Number	Error	Resolution
1	Action Manager Initialization failed with send trap socket	N/A
3	Send trap action: CreateTrapRequest failed	N/A
4	Send trap action: Send trap failed	N/A
500	Socket Error: <i>value</i>	N/A
501	<system call> failed while launching Application handler : <error message>	N/A
1001	Action Manager connect to database failed	Check NerveCenter database. Check ODBC connection string.
1002	InitializePlatformSocket failed for <i>value</i>	Use the Administrator to check the configuration settings for NetNodeNotify.
1004	Can't open database	Check NerveCenter database. Check ODBC connection string.
1005	No connection string for Log to Database action	Check ODBC connection string.
1006	Reconfiguration: InitializePlatformSocket failed for <i>value</i>	Check Notify page in NC Admin.

TABLE A-3. Action Manager Error Messages (Continued)

Error Number	Error	Resolution
1010	Log to Event View error: RegisterEventSource for <i>value</i> failed with error code <i>value</i>	Check system configuration.
1011	Log to Event View error: ReportEvent failed with error code <i>value</i>	Check system configuration.
1012	Socket Creation Failed in InitSmtpSocket With Error = <i>value</i>	Check socket resource on the computer.
1013	Protocol Bind Failed in InitSmtpSocket With Error = <i>value</i>	Check TCP/IP configuration.
1014	Connect to SMTP Host Failed in InitSmtpSocket With Error= <i>value</i>	Use the Administrator to check the configuration settings for SMTP host name.
1015	Ioctlsocket Failed (Setting Non-Blocking Mode) in InitSmtpSocket With Error= <i>value</i>	Check TCP/IP configuration.
1016	Send Packet Failed in SendSmtpPacket With Error= <i>value</i>	Check SMTP server.
1017	Receive Packet Failed in RecvSmtpPacket for %1 With Error= <i>value</i>	Check SMTP server.
1018	Received Unexpected Response= <i>value</i> in RecvSmtpPacket	Check SMTP server.
1019	Log to Database error: Database connection not open	Check NerveCenter database. Check SQL Server.
1020	Log to Database error: can not open log table	Check NC_Log table in NerveCenter database.
1021	Log to Database exception: <i>value</i>	Check NerveCenter database. Check SQL Server. Check NC_Log table in NerveCenter database.
1022	Logging to a File error: No filename presented to Log To File action.	Make sure there is a file name associated with LogToFile action for alarm transitions.
1023	Logging to a File error: Unable to Write LogFile: <i>value</i> Error Code = <i>value</i> .	Check security on file system. Make sure the file is writable.

TABLE A-3. Action Manager Error Messages (Continued)

Error Number	Error	Resolution
1024	Logging to a File error: Unable to Create LogFile: <i>value</i> Error Code = <i>value</i> .	Check security on file system. Make sure the file is writable.
1025	Logging to a File error: Unable to Seek EOF for LogFile: <i>value</i> Error Code = <i>value</i>	Check security on file system. Make sure the file is writable.
1026	Logging to a File error: Unable to Truncate LogFile.	Delete the file or repair the file format.
1027	Could Not Logoff from MAPI <i>value</i> , Error= <i>value</i>	Check MAPI service in the system.
1028	Could Not Load MAPI32.DLL.	Search mapi32.dll in the system and ensure sure it is in the system path.
1029	Could Not Get MAPILogon Address.	Check mapi32.dll in the system and ensure it is a good version.
1030	Could Not Get MAPILogoff Address.	Check mapi32.dll in the system and ensure it is a good version.
1031	Could Not Get MAPISendMail Address.	Check mapi32.dll in the system and ensure it is a good version.
1032	Could Not Logon to MAPI <i>value</i> , Error= <i>value</i> .	Check MAPI configuration and ensure to have created the profile.
1033	Could Not SendMail to MAPI <i>value</i> , Error= <i>value</i> .	Check MAPI configuration and ensure to have created the profile.
1034	Paging action error: Dial failed.	Check modem configuration.
1035	Running an NT Command error: No Command Presented to Run Command.	Make sure there is a command associated with all Windows Command actions specified for alarm transitions.
1036	Running an NT Command error: Command <i>value</i> Completed with ReturnCode <i>value</i>	Check command line.
1037	Command action <i>value</i> failed : Application handler <i>value</i> was killed	NCServer will bring it up for the next Command action

TABLE A-3. Action Manager Error Messages (Continued)

Error Number	Error	Resolution
1038	Command action <action> failed : <i>value</i>	If error says "Too many open files" close some open files. If error says "fork failure" close some applications.
1039	Unable to launch Application handler: <i>value</i>	If error says "Too many open files" close some open files. If error says "fork failure" close some applications.
1040	Perl subroutine <i>value</i> failed: <i>message</i>	
1500	The connection to <i>value</i> was closed	
1505	<i>value</i> . The address is already in use	Make sure you are not running two instances of the same application on the same machine.
1506	<i>value</i> . The connection was aborted due to timeout or other failure	Make sure the physical network connections are present.
1507	<i>value</i> . The attempt to connect was refused	Make sure the server is running on the remote host.
1508	<i>value</i> . The connection was reset by the remote side	Make sure the remote peer is up and running.
1509	<i>value</i> . A destination address is required	A destination address or host name is required.
1510	<i>value</i> . The remote host cannot be reached	Make sure the routers are working properly.
1511	<i>value</i> . Too many open files	Close any open files.
1512	<i>value</i> . The network subsystem is down	Reboot the machine.
1513	<i>value</i> . The network dropped the connection	Make sure the peer is running and the network connections are working.
1514	<i>value</i> . No buffer space is available	This might be because you are running several applications, or an application is not releasing resources.

TABLE A-3. Action Manager Error Messages (Continued)

Error Number	Error	Resolution
1515	<i>value</i> . The network cannot be reached from this host at this time	Make sure the routers are functioning properly.
1516	<i>value</i> . Attempt to connect timed out without establishing a connection	Make sure the machine is running and on the network.
1517	<i>value</i> . The host cannot be found	Make sure you can ping the host. Check your hosts file or DNS server.
1518	<i>value</i> . The network subsystem is unavailable	Make sure the network services are started on machine.
1519	<i>value</i> . Invalid host name specified for destination	The host name cannot be resolved to an IP address. Enter the name to the hosts file or DNS server.
1520	<i>value</i> . The specified address is not available	Make sure the host name is not zero—try pinging the host.
2001	Command line too long: <i>value</i>	Check the Windows Command Action. Command line exceeds maximum allowed length of 2048 characters.
2002	Send trap action failed for alarm <i>alarm name</i> due to the following reason: <i>string</i>	Check the source or destination host name. Check the enterprise. If this action was not caused by a trap, it will fail if the enterprise is \$P. Check to see that the varbinds are legal for the currently loaded MIB.
2003	Tapi initialize failed, paging will not work	Check the comm port/modem configuration and check the tapi32.dll version.
2004	Empty host for SMTP mail	If SMTP actions are used, use the Administrator to enter the SMTP mail host name.
2005	Empty profile for MAPI, MS Mail will not work	If MS mail actions are used, use the Administrator to enter the SMTP mail host name.

TABLE A-3. Action Manager Error Messages (Continued)

Error Number	Error	Resolution
2006	Fire Trigger Action error: Invalid node name: <i>value</i>	A node name was specified directly in an action and that node doesn't exist in the system.
2007	Fire Trigger Action error: Invalid property name: <i>value</i>	A property was specified directly in an action and that property doesn't exist in the system.
2008	Fire Trigger Action error: Invalid subobject: <i>value</i>	A subobject was specified directly in an action and that subobject doesn't exist in the system.
2010	Error Sending SMTP Mail. <i>Value</i> messages may have been lost.	

Alarm Filter Manager Error Messages

Following is a list of Alarm Filter Manager error messages.

TABLE A-4. Alarm Filter Manager Error Messages

Error Number	Error	Resolution
1	Lookup failed on linenummer <i>value</i> in File <i>value</i> .	
3001	Alarm Filter Manager Initialization successfully finished	

Deserialize Manager Error Messages

Following is a list of Alarm Filter Manager error messages.

TABLE A-5. Deserialize Manager Error Messages

Error Number	Error	Resolution
1	Lookup failed on linenummer <i>value</i> in File <i>value</i> .	

TABLE A-5. Deserialize Manager Error Messages

Error Number	Error	Resolution
3001	Deserialize Thread Manager Initialization successfully finished	

Flatfile Error Messages

Following is a list of Flatfile Manager error messages.

TABLE A-6. Flatfile Manager Error Messages

Error Number	Error	Resolution
1	Lookup failed on linenumber <i>value</i> in File <i>value</i> .	
3001	Flat File Initialization successfully finished	

Inform NerveCenter Error Messages

Following is a list of Inform NerveCenter Manager error messages.

TABLE A-7. Inform NerveCenter Manager Error Messages

Error Number	Error	Resolution
1	Lookup failed on linenumber <i>value</i> in File <i>value</i> .	
3001	InformNC Manager Initialization successfully finished	

Inform OV Error Messages

Following is a list of Inform OV Manager error messages.

TABLE A-8. Inform OV Manager Error Messages

Error Number	Error	Resolution
2	ReceiveHandShakeResponse FALSE byte not correct.	N/A
500	Socket Error: <i>value</i> .	N/A
501	<system call> failed while launching Application handler : <error message>.	N/A
1002	InitializePlatformSocket failed for <i>value</i> .	Use the Administrator to check the configuration settings for NetNodeNotify.
1003	No platform host for InformOV.	Use the Administrator to check the configuration settings for NetNodeNotify.
1006	Reconfiguration: InitializePlatformSocket failed for <i>value</i> .	Check Notify page in the Administrator.
1007	CInformOVEventSocket::Init() failed with invalid operation: <i>value</i> .	Use the Administrator to check the configuration settings for NetNodeNotify.
1039	Unable to launch Application handler: <i>value</i> .	If error says "Too many open files" close some open files. If error says "fork failure" close some applications.
1040	Perl subroutine <i>value</i> failed: <i>message</i> .	
1500	The connection to <i>value</i> was closed.	
1505	<i>value</i> . The address is already in use.	Make sure you are not running two instances of the same application on the same machine.
1506	<i>value</i> . The connection was aborted due to timeout or other failure.	Make sure the physical network connections are present.
1507	<i>value</i> . The attempt to connect was refused.	Make sure the server is running on the remote host.
1508	<i>value</i> . The connection was reset by the remote side.	Make sure the remote peer is up and running.
1509	<i>value</i> . A destination address is required.	A destination address or host name is required.

TABLE A-8. Inform OV Manager Error Messages (Continued)

Error Number	Error	Resolution
1510	<i>value</i> . The remote host cannot be reached.	Make sure the routers are working properly.
1511	<i>value</i> . Too many open files.	Close any open files.
1512	<i>value</i> . The network subsystem is down.	Reboot the machine.
1513	<i>value</i> . The network dropped the connection.	Make sure the peer is running and the network connections are working.
1514	<i>value</i> . No buffer space is available.	This might be because you are running several applications, or an application is not releasing resources.
1515	<i>value</i> . The network cannot be reached from this host at this time.	Make sure the routers are functioning properly.
1516	<i>value</i> . Attempt to connect timed out without establishing a connection.	Make sure the machine is running and on the network.
1517	<i>value</i> . The host cannot be found.	Make sure you can ping the host. Check your hosts file or DNS server.
1518	<i>value</i> . The network subsystem is unavailable.	Make sure the network services are started on machine.
1519	<i>value</i> . Invalid host name specified for destination.	The host name cannot be resolved to an IP address. Enter the name to the hosts file or DNS server.
1520	<i>value</i> . The specified address is not available.	Make sure the host name is not zero—try pinging the host.
2001	Command line too long: <i>value</i> .	Check the Windows Command Action. Command line exceeds maximum allowed length of 2048 characters.
2006	Fire Trigger Action error: Invalid node name: <i>value</i> .	A node name was specified directly in an action and that node doesn't exist in the system.

TABLE A-8. Inform OV Manager Error Messages (Continued)

Error Number	Error	Resolution
2007	Fire Trigger Action error: Invalid property name: <i>value</i> .	A property was specified directly in an action and that property doesn't exist in the system.
2008	Fire Trigger Action error: Invalid subobject: <i>value</i> .	A subobject was specified directly in an action and that subobject doesn't exist in the system.
2009	Inform OV send Packet Failed for platform socket <i>value</i> .	
3001	Inform OV Manager Initialization successfully finished.	
3002	CInformOVEventSocket::OnClose with code <i>value</i> .	

LogToDatabase Manager Error Messages

Following is a list of Log to Database Manager error messages.

TABLE A-9. Log to Database Manager Error Messages

Error Number	Error	Resolution
1002	Initialization failed.	Check WriteBuiltInTriggers.
1100	Unknown database exception.	Check NerveCenter database. Log segment might be full.
1101	Failed to connect to database.	Check NerveCenter database. Check ODBC connection string.
1102	Failed to connect to database.	Check NerveCenter database. Check ODBC connection string.
1103	Version table validation failed. NC_Version table doesn't exist in database.	
1104	Write to database failed.	Log segment might be full or the database might have gone down.

TABLE A-9. Log to Database Manager Error Messages

Error Number	Error	Resolution
1203	Can't enable discovery model.	Check the alarm table and the state of alarms (off or on).
3001	Database Thread Initialization successfully finished.	
3002	The database state has changed. Either it has gone down or come up.	

LogToFile Manager Error Messages

Following is a list of Log to File Manager error messages.

TABLE A-10. Log to File Manager Error Messages

Error Number	Error	Resolution
1	Lookup failed on linenumber <i>value</i> in File <i>value</i> .	
3001	LogToFile Manager Initialization successfully finished	

OpC Manager Error Messages

Following is a list of OpC Manager error messages.

TABLE A-11. Inform OpC Manager Error Messages

Error Number	Error	Resolution
1	Lookup failed on linenumber <i>value</i> in File <i>value</i> .	
3001	OpC Manager Initialization successfully finished	

Poll Manager Error Messages

Following is a list of Poll Manager error messages.

TABLE A-12. Poll Manager Error Messages

Error Number	Error
3001	Poll Manager Initialization successfully finished
3002	CPollManagerWnd:OnPollOnOff, PreCompild of PollEvent with Poll Id %ld failed

Protocol Manager Error Messages

Following is a list of Protocol Manager error messages.

TABLE A-13. Protocol Manager Error Messages

Error Number	Error	Resolution
1	Building copy of node list failed.	N/A
2	Building copy of poll property list failed.	N/A
3	Initialization of protocol methods failed	N/A
4	Initialization of ping socket failed.	N/A
5	Creation of SNMP socket failed, socket error code: %d	N/A
6	Error in ping socket: %s	N/A
7	Error in ping socket: create socket failed.	N/A
8	Error in ping socket: async select failed.	N/A
1000	Looking for the %s key in the configuration settings.	Use the Administrator to enter the SNMP values in the configuration settings.
1001	Ncuser user ID is not found.	Add ncuser user ID to your system.
3000	Initialization successfully finished.	N/A
3001	Invalid value in configuration settings for SNMP retry interval, using default of 10 seconds.	Use the Administrator to enter a value for the SNMP retry interval.

TABLE A-13. Protocol Manager Error Messages (Continued)

Error Number	Error	Resolution
3002	Invalid value in configuration settings for number of SNMP retries, using default of 3 retries.	Use the Administrator to enter a value for the SNMP retries.
3003	Invalid value in configuration settings for default SNMP port, using default of 161.	Use the Administrator to enter a value for the default SNMP port number.

PA Resync Manager Error Messages

Following is a list of PA Resync Manager error messages.

TABLE A-14. PA Resync Manager Error Messages

Error Number	Error	Resolution
1	Error getting local host name for encoding resync request, socket error code: %d	N/A
2	Encoding resync request failed	N/A
3	Sending resync request failed with zero bytes sent	N/A
4	Sending resync request failed: %s	N/A
5	Memory allocation error, trying to notify of connection status	N/A
6	Memory allocation error, creating node list	N/A
7	Memory allocation error, creating a resync node	N/A
8	Parent status not sent during resync	
10	Parents not computed during resync with map host. Check OVPA. OVPA database must have nc host node.	
500	Socket Error: (%d)	
1000	Error looking for the %s key in the NerveCenter configuration settings	Use the Administrator to enter configuration settings.

TABLE A-14. PA Resync Manager Error Messages (Continued)

Error Number	Error	Resolution
1001	Attempt to connect to %s on port %d failed: %s	Make sure the platform host is up and running and that the name exists in the hosts file.
1002	Resync connection attempt failed: %d	Make sure the platform host is up and the platform adapter is running.
1500	The connection to % was closed	
1501	Send failed with zero bytes sent	
1505	%s. The address is already in use	Make sure you are not running two instances of the same application on the same machine.
1506	%s. The connection was aborted due to timeout or other failure	Make sure the physical network connections are present.
1507	%s. The attempt to connect was refused	Make sure the server is running on the remote host.
1508	%s. The connection was reset by the remote side	Make sure the remote peer is up and running.
1509	%s. A destination address is required	A destination address or host name is required.
1510	%s. The remote host cannot be reached	Make sure the routers are working properly.
1511	%s. Too many open files	Close any open files.
1512	%s. The network subsystem is down	Reboot the machine.
1513	%s. The network dropped the connection	Make sure the peer is running and the network connections are working.
1514	%s. No buffer space is available	This might be because you are running several applications, or an application is not releasing resources.
1515	%s. The network cannot be reached from this host at this time	Make sure the routers are functioning properly.

TABLE A-14. PA Resync Manager Error Messages (Continued)

Error Number	Error	Resolution
1516	%s. Attempt to connect timed out without establishing a connection	Make sure the machine is running and on the network.
1517	%s. The host cannot be found	Make sure you can ping the host, check you hosts file or DNS server.
1518	The network subsystem is unavailable	Make sure the network services are started on machine.
1519	%s. Invalid host name specified for destination	The host name cannot be resolved to an IP address. Enter the name to the hosts file or DNS server.
1520	The specified address in not available	Make sure the host name is not zero. Try pinging the host.
3000	initialization successfully finished	N/A
3001	Node resync from map host was not requested because either host name or port number is missing	If you are trying to disable a connection to the platform adapter, then this message is OK. If you want to be connected to the platform adapter, then use the Administrator to check the map host settings.
3500	Connection to %s was successful	N/A

Server Manager Error Messages

Following is a list of Server Manager error messages.

TABLE A-15. Server Manager Error Messages

Error Number	Error	Resolution
1	OLE initialization failed. Make sure that the OLE libraries are the correct version.	N/A
2	Perl create failed.	N/A

TABLE A-15. Server Manager Error Messages (Continued)

Error Number	Error	Resolution
3	Initialization of <i>value</i> manager thread failed.	N/A
4	Failed to restore MibDirectory in configuration settings.	N/A
5	Failed to open configuration settings while trying to restore mib information.	N/A
6	Discrepancy in data. File: SERVER_CS.CPP, Line: <i>value</i> .	N/A
10	Conflict in data. File: SERVER_CS.CPP, Line: <i>value</i> .	N/A
11	Internal Error. File: SERVER_CS.CPP, Line: <i>value</i> .	N/A
20	Cannot read configuration settings value: Bind.	N/A
21	Cannot connect to Tcpip configuration settings information.	N/A
22	Cannot read configuration settings value: IPAddress.	N/A
23	Couldn't find <i>value</i> in map.	N/A
24	Error while reading database. Poll/Mask: <i>value</i> uses a simple trigger that doesn't exist in database.	N/A
25	Please report error number <i>value</i> to technical support.	N/A
26	User validation failed: Unable to communicate with nsecurity process : <i>value</i> .	~
1001	Windows sockets initialization failed.	Install TCP/IP.
1002	Initialization failed, cannot find nperl.pl.	Check NCPperl.pl location.
1003	Failed to open MIB: <i>value</i> .	Check MIB location.
1004	Failed to parse MIB.	Invalid MIB. Check configuration to see if the correct MIB is specified.

TABLE A-15. Server Manager Error Messages (Continued)

Error Number	Error	Resolution
1010	Failed to validate poll: <i>value</i> . The poll will be turned off.	Check the poll condition using the Client Application.
1100	<i>value</i> (database error).	Try to resolve using the message. If not, call support.
1101	Failed to connect to database. ODBC Connection String in configuration settings is invalid or can't find database server.	Use InstallDB to re-create the ODBC connection string.
1102	Failed to connect to database. ODBC Connection String in configuration settings is empty.	Use InstallDB to re-create the ODBC connection string.
1103	Version table validation failed. NC_Version table doesn't exist in database.	Upgrade the NerveCenter database to version 3.5 standards.
1200	Failed to open configuration settings while trying to restore mib information.	Use the NerveCenter Administrator to check the configuration settings. Invalid key is likely.
1201	Updated License key is invalid.	An invalid license key was entered. Check the key.
1202	Cannot connect to configuration settings.	Use the NerveCenter Administrator to check the configuration settings. Invalid key is likely.
1203	Cannot open key <i>value</i> .	Use the NerveCenter Administrator to check the configuration settings.
1204	Cannot add value <i>value</i> .	Use the NerveCenter Administrator to check the configuration settings. Invalid key is likely.
1205	Cannot read configuration settings value in MapSubNets key.	Use the NerveCenter Administrator to check the configuration settings. Invalid key is likely.
1206	Invalid configuration settings Entry for the value Method in the Platform key.	Only Manual and Auto are allowed. Check for case.
1207	Cannot read configuration settings value: <i>value</i>	Use the NerveCenter Administrator to check the configuration settings. Invalid key is likely.

TABLE A-15. Server Manager Error Messages (Continued)

Error Number	Error	Resolution
1208	Cannot write configuration settings Value: <i>value</i>	Use the NerveCenter Administrator to check the configuration settings. Invalid key is likely.
1210	Cannot find License key in configuration settings.	Use the NerveCenter Administrator to check the configuration settings. Invalid key is likely.
1300	<i>value</i> (Import behavior/database error).	Try to resolve using the message. If not, call support.
1313	Server alarm instance maximum exceeded. Please restart Server.	Restart server.
2001	The account NCServer.exe is running under does not have the advanced user right "Act as part of the operating system."	Use User Manager to give advanced user right to the group or user that NCServer is running under. You will have to stop and restart NCServer.exe
2002	The user or a group the user belongs to does not have the advanced user right "Logon as a batch job."	Use User Manager to give advanced user right to the group or user.
2003	The user ID <i>value</i> does not exist.	Type in a user ID that exists. Check User Manager.
2004	The password is incorrect for user ID <i>value</i> .	Type in a legal password for the user ID you entered
2005	License violation. Exceeded number of allowed nodes. The number of managed nodes exceeds the limits of the license.	Either unmanage some nodes or contact your authorized sales representative for an upgrade.
2006	One of the following messages: <ul style="list-style-type: none"> ◆ Invalid Product ID in license key. ◆ No nodes specified in license. ◆ No users specified in license. ◆ Illegal start date specified. 	Check with customer support to see that the license was generated correctly.
	Invalid License Key.	NerveCenter could not decode the license. Check for typographical errors in the key or call support to get the key validated and/or replaced.

TABLE A-15. Server Manager Error Messages (Continued)

Error Number	Error	Resolution
	License will expire in less than 14 days.	Your NerveCenter evaluation license will expire within 14 days. Contact sales or support to get the license extended.
	License has expired.	Your NerveCenter evaluation license has expired. Contact sales or support to get the license extended.
2007	The ncadmins, ncusers not defined on the server machine and the user does not have root permissions.	Log in as root to connect to the Server. If you cannot log in as root, do one of the following: <ul style="list-style-type: none"> ◆ If your system uses NIS, define the groups ncadmins and ncusers on the NIS server machine, in the /etc/group file, and rebuild the NIS database. ◆ If your system does not use NIS, define the two groups in the /etc/group file of the machine where the Server is running.
2008	User does not have either administrator or user permissions.	Log in as root to connect to the Server. If you cannot log in as root, do one of the following: <ul style="list-style-type: none"> ◆ If your system uses NIS, include your user ID in either the ncadmins or ncusers group on the NIS server machine, in the /etc/group file, and rebuild the NIS database. ◆ If your system does not use NIS, include your user ID in either the ncadmins or ncusers group on the machine where the Server is running.
3001	Request to delete the node <i>value</i> failed because the node doesn't exist.	N/A
3002	Failed to find socket in server's map. Line: <i>value</i> .	

TABLE A-15. Server Manager Error Messages (Continued)

Error Number	Error	Resolution
3003	Exiting due to a SIGTERM signal.	
3004	Primary thread initialization successful.	

Trap Manager Error Messages

Following is a list of Trap Manager error messages.

TABLE A-16. Trap Manager Error Messages

Error Number	Error	Resolution
1	Error in TrapManagerWnd::Initialize - failed to create GetHostByAddr thread.	
2	Error in TrapManagerWnd::LaunchTrapper - failed to create trapper process.	
3	Error in TrapManagerWnd::CreateCheckTrapperThread - failed to create new thread.	
5	Error in TrapManagerWnd::InitializeMSTrapService - failed to get proc address.	
6	Error in TrapManagerWnd::InitializeMSTrapService - error from SnmpMgrTrapListen (last error).	
7	Error in TrapManagerWnd::InitializeMSTrapService - failed to create trap listen thread.	
8	Error in TrapManagerWnd::Initialize - Failed to create trap stream socket.	
9	Error in TrapManagerWnd::Initialize - Failed to listen on trap stream socket.	
10	Error in TrapManagerWnd::OnTraceTraps - Failed to create trace file for traps.	

TABLE A-16. Trap Manager Error Messages (Continued)

Error Number	Error	Resolution
1001	CTrapManagerWnd::OnTrapExist - gethostname from trap data with snmptrap failed for <i>value</i> .	
1002	Error in trap service or trap service down.	Check SNMP service under Windows.
1003	CTrapManagerWnd::OnInvalidSignature - Error in receiving data on NC socket.	Check for consistency in version numbers of trapper and NerveCenter executables.
1004	Expected MSTRAP or OVTRAP in NerveCenter configuration settings.	Reinstall NerveCenter and make sure you choose appropriate platform integration.
2001	MS Trap service threw exception in GetTrap.	Make sure you aren't accidentally making SNMP get requests to port 162.
2002	Error processing trap data.	Make sure you aren't accidentally making SNMP get requests to port 162.
3001	Trap Manager Initialization successfully finished.	
3002	Check Trapper—Trapper process died. restarting Trapper.	

NerveCenter installation Error Messages (UNIX)

Following is a list of NerveCenter installation error messages.

TABLE A-17. NerveCenter Installation Error Messages (UNIX)

Error	Resolution
Space under <i>dirname</i> is INSUFFICIENT to install OpenService NerveCenter	Free up space in the file system by removing files, or choose another place for installation.
The directory <i>dirname</i> must reside on a local disk	The directory you specified for OpenService NerveCenter installation is on a disk that is not on the local file system. Pick a new directory or re-mount the disk.

TABLE A-17. NerveCenter Installation Error Messages (UNIX) (Continued)

Error	Resolution
Write permission is required by root for <i>dirname</i> directory	The directory you specified for OpenService NerveCenter installation does not have write permission for root. Choose another directory or change the permissions.
Please create the desired destination directory for NerveCenter and re-run the installation script	The directory you specified for OpenService NerveCenter installation does not exist. Choose another directory or create the original.
Invalid mount point	The installation script could not find the CD-ROM drive and prompted you for its location. The path you specified was not valid. Verify that the drive exists, is mounted, and is configured correctly.
<i>ProcessName</i> is running on the system. Please exit from (or kill) <i>processName</i> process.	The installation script found that the <i>nervectr</i> or <i>ovw</i> process was running. Exit from or kill the process and re-run the installation script.
These processes must be stopped before OpenService NerveCenter can be installed. Please kill these processes and re-run the installation script.	The installation script found processes that need to be killed before installation, asked if you wanted it to stop them, and you said no. You must manually exit from or kill the processes and re-run the installation script.
<i>hostname</i> is not a valid host name	The host that you provided to the script for integration with another application is not a valid host. Check the name of the host (capitalization, spelling, and so on) and try again.
<i>hostname</i> does not have OpenView installed on it.	Before configuring an OpenView host for OpenService NerveCenter's integration with OpenService LANAlert or OperationsCenter, OpenView must already be installed on the host. Stop your OpenService NerveCenter installation and review the prerequisites.
OpenView has not been configured on this system yet.	Before configuring an OpenView host for OpenService NerveCenter's integration with LANAlert or OperationsCenter, you must have already done the basic OpenView configuration for the host. Rerun the installation script, make sure to answer "Yes" when questioned whether you want to configure OpenView for this host, and then proceed with your integration with other applications.
I don't know how to install on this architecture	Installation is supported for HP-UX and Solaris. The script issues this message if attempting to install on an architecture that is not in this set.

TABLE A-17. NerveCenter Installation Error Messages (UNIX) (Continued)

Error	Resolution
Can't cd to <i>installation_path</i> /userfiles	Make sure the directory exists and has appropriate permissions.
Can't open <i>hostname.conf</i>	The script couldn't create the file or couldn't open an existing configuration file. Check <i>installation_path</i> /userfiles to make sure that root has permission to write in this directory, that <i>hostname.conf</i> has read permission set, if it exists, and that <i>localhost.conf</i> exists and has read permission set.
Can't create <i>hostname.ncdb</i> Can't create <i>hostname.node</i>	The script was attempting to create the indicated file by copying data from another file. Check <i>installation_path</i> /userfiles to make sure that root has permission to write in this directory, and that <i>localhost.ext</i> exists and has read permission set.
Can't open /etc/rc Couldn't re-create /etc/rc Couldn't modify /etc/rc	The script couldn't modify /etc/rc to call the OpenService NerveCenter rc script. Edit the file and add a line that executes <i>installation_path</i> /bin/rc.openservice. There's no need to rerun the installation script after this correction.
Can't append to /etc/rc.local	The script couldn't modify /etc/rc.local to call the OpenService NerveCenter rc script. Edit the file and add a line that executes <i>installation_path</i> /bin/rc.openservice. There's no need to rerun the installation script after this correction.
Can't create /etc/rc2.d/K94ncservice on Solaris	The script couldn't create the OpenService NerveCenter rc script /etc/rc2.d/K94ncservice on Solaris or K940ncservice on HP-UX
Can't create /etc/rc2.d/K940ncservice on HP-UX	. Copy <i>installation_path</i> /bin/rc.openservice to /etc/rc2.d//K94ncservice on Solaris or K940ncservice on HP-UX . There's no need to rerun the installation script after this correction.

TABLE A-17. NerveCenter Installation Error Messages (UNIX) (Continued)

Error	Resolution
An error occurred in trying to contact the Server " <i>hostname</i> ". As a result, the information that you have specified cannot be used to complete this NIS update. Unable to modify <i>filename</i> . It doesn't exist! Unable to modify <i>filename</i> . File size is 0!	The script was attempting to update system services and failed. Correct the specific error (perhaps the host name or file name was entered incorrectly) and rerun the script. If the error isn't easily corrected, you can edit <i>/etc/services</i> yourself. Make sure that the following lines are included in the file: SNMP 161/udp SNMP-trap 162/udp If you're running NIS, be sure to make these changes on the NIS server, change to the NIS directory, and run <i>make services</i> .

OpenView Configuration Error Messages (UNIX)

Following is a list of OpenView configuration error messages.

TABLE A-18. OpenView Configuration Error Messages (UNIX)

Error	Resolution
Configuration of OpenView was not entirely successful. You need to go back and double-check the steps that failed above.	This message will be displayed if any part of the OpenView configuration didn't succeed. Scroll back through the output of the script, looking for messages that include the word <i>FAILED</i> . Immediately following such a line will be the specific system error messages that resulted from the part of the script that failed.
Installing registration...FAILED	The script was attempting to copy a file into <i>NNM_dir/registration/C</i> , where <i>NNM_dir</i> is the location of your OpenView installation. Make sure that this directory exists and that root has write permission for it.
Couldn't create <i>NNM_dir/help/C/ncapp</i>	The script was attempting to create the directory <i>NNM_dir/help/C/ncapp</i> , where <i>NNM_dir</i> is the location of your OpenView installation. Make sure that <i>help/C</i> exists and that root has write permission for it.

TABLE A-18. OpenView Configuration Error Messages (UNIX)

Error	Resolution
Installing Help...FAILED	The script was attempting to copy files into <i>Network Node Manager_dir/help/C/ncapp</i> . Make sure the directory exists and that root has write permission for it. If you got the previous error message, you will also receive this one.
Installing Fields...FAILED	The script was attempting to copy a file into <i>NNM_dir/fields/C</i> . Make sure the directory exists and that root has write permission for it.
Installing Symbols...FAILED	The script was attempting to copy a file into <i>NNM_dir/symbols/C</i> . Make sure the directory exists and that root has write permission for it.
Installing Bitmaps...FAILED	The script was attempting to copy files into <i>NNM_dir/bitmaps/C</i> . Make sure the directory exists and that root has write permission for it.
Notifying <<OpenView...>> FAILED	The script was attempting to execute <i>ovw</i> . Make sure that root has appropriate permissions for <i>ovw</i> and that you have run <i>ovstartup</i> on this computer.
Installing Events...FAILED	The script was attempting to execute <i>xnmevents</i> . Make sure that root has appropriate permissions for <i>xnmevents</i> and that <i>xnmtrap</i> is not running on this computer.

Troubleshooting NerveCenter

B

NerveCenter's complexity means that users will inevitably run into difficulties at some point. Before calling NerveCenter Technical Support, there are several first steps you can take. Besides checking the obvious—the NerveCenter Server is running, the license has not expired, etc.—you may want to look at information found in this appendix.

This appendix includes the following sections:

Section	Description
<i>Common problems on page 271</i>	Lists some of the most common problems NerveCenter users face.
<i>Using Trace Counters to Troubleshoot NerveCenter on page 273</i>	Explains how advanced NerveCenter users can use trace counters to detect problems.
<i>Troubleshooting ASN.1 files on page 283</i>	Explains how NerveCenter users can edit MIB files that fail to compile.

Common problems

The following list includes some of the more common problems users face when administering NerveCenter.

The NerveCenter Server

- ◆ *UNIX will not start the NerveCenter Server on page 40.*
- ◆ *An alarm causes the NerveCenter Server to crash every time I start it on page 40.*
- ◆ *The NerveCenter Server does not start on Windows on page 40.*
- ◆ *I need to get a better idea of what the NerveCenter Server is doing on Windows. Can I temporarily run it as a process? on page 40*
- ◆ *UNIX will not start the NerveCenter Administrator on page 51.*

- ◆ *While trying to connect to a NerveCenter Server I get the message: The server did not respond on page 51.*
- ◆ *I misspelled a server name while trying to connect and now the misspelled name appears in the NerveCenter Administrator Server Name list on page 51.*
- ◆ *When I try to connect to a NerveCenter Server it tells me: Number of allowed client connection exceeded on page 78.*
- ◆ *I need to make the same changes to several NerveCenter Servers on page 78.*
- ◆ *Importing imputil.ini caused unwanted changes to a NerveCenter Server on page 78.*

NerveCenter's node list

- ◆ *NerveCenter is not filtering a node by a capability on page 129.*
- ◆ *After setting an IP filter, a node that should be masked out still appears in the node list on page 129.*
- ◆ *Even though I have enabled Process Traps From Unknown Nodes, NerveCenter does not update its node list when it receives a trap from an unknown node on page 129.*
- ◆ *NerveCenter does not recognize my network management platform as a valid source of node data on page 129.*
- ◆ *NerveCenter is not receiving node data from my network management platform on page 130.*
- ◆ *The IPSweep behavior model will not work on page 130.*
- ◆ *The NerveCenter node list contains two nodes with the same address but different names on page 130.*
- ◆ *NerveCenter deletes a node I added manually on page 130.*
- ◆ *NerveCenter adds a node I deleted manually on page 130.*
- ◆ *I'm seeing several errors recorded in the application event log window stating that ipsweep.exe is not running on page 131.*

Alarm actions

- ◆ *NerveCenter is not sending SMTP mail notifications on page 197.*
- ◆ *Microsoft mail notifications are not being sent as NerveCenter on page 197.*
- ◆ *NerveCenter is not dialing pages correctly on page 197.*

- ◆ *The logs created by my behavior models are using too much disk space on page 197.*

The NerveCenter database

- ◆ *The server shut down gracefully, but event log said that the database was not found. Where did the updates to the database go? on page 227*
- ◆ *Running SerializeDB from the command line keeps failing on page 227.*
- ◆ *SerializeDB won't work from the application or the command line on page 227.*
- ◆ *The data in the database is not what was imported from the serialized file on page 227.*

Management Information Bases (MIBs)

- ◆ *A MIB won't compile on page 239.*
- ◆ *A MIB won't load on page 240.*

Using Trace Counters to Troubleshoot NerveCenter

A useful tool for troubleshooting NerveCenter is the trace counters feature. Trace counters enable NerveCenter to keep track of its own activities, such as the number of SNMP traps that have been received, polls requested, Informs sent, and quite a few other operations. The cumulative count for an operation reflects total activity for either of the following durations:

- ◆ For as long as the NerveCenter Server has been running
- ◆ If you have reset a counter, since the reset was performed.

Trace counters can help you troubleshoot communication or behavior model problems. For example, if Informs are not being received by your network management platform for a particular network condition, you might trace a backward path starting with the Inform Action counters to find out where the problem arises. If informs are being sent, the problem is not with your alarm, polls, or masks. If no Informs are requested or sent, you might examine whether triggers are being issued or whether SNMP traps are being captured in trap masks by examining the counters in the Trigger and Trap pages.

If you are having difficulties with NerveCenter, a OpenService Technical Support representative may provide further instructions for using the Trace counters, including enabling trace logging.

**NOTE**

NerveCenter's trace logging feature should only be used as directed by Technical Support. Trace logging quickly consumes large blocks of memory and could impact Server performance.

Even though the data presented by the trace counters are read-only, you can reset a counter. See [Using Trace Counters on page 275](#) for details about viewing, resetting, and refreshing counters.

The following sections describe the meaning of each counter:

- ◆ [Alarm Action Counters on page 277](#)
- ◆ [Database Counters on page 277](#)
- ◆ [Inform Counters on page 278](#)
- ◆ [Inform NerveCenter Counters on page 278](#)
- ◆ [Log to Database Counters on page 279](#)
- ◆ [Log to File Counters on page 279](#)
- ◆ [Server Counters on page 280](#)
- ◆ [Node Source Counters on page 280](#)
- ◆ [OPC Msg Counters on page 281](#)
- ◆ [Poll Counters on page 281](#)
- ◆ [Trap Counters on page 282](#)
- ◆ [Trigger Counters on page 282](#)

Using Trace Counters

This section describes how to access and use the trace counters.

TO VIEW NerveCenter TRACE COUNTERS

1. From the Server menu, choose **Trace Counts**.
The Trace Counters window is displayed.
2. Select one of the tabs.
The corresponding set of counters is displayed.
3. Select the **Refresh** button to update all counters.

Once you have the counters displayed, you can reset one or more counters as described in [Resetting counters on page 275](#). You may also periodically need to update all counters as described in [Refreshing the Trace Counter display on page 276](#).

Resetting counters

When using NerveCenter Trace Counters to troubleshoot a problem, you may want to reset one or more counters. For example, if Informs are not being received by your network management platform for a particular network condition, you can isolate the problem by turning off alarms not related to the condition, resetting the related counters, and then tracing the activity for the alarm you want to monitor.

TO RESET NerveCenter TRACE COUNTERS

1. In the Trace Counters window, select the page containing the counters you want to reset.
 2. Do either of the following:
 - ◆ Select the **Reset** checkbox next to the counter or counters you want to reset, and then select the **Reset** button. The counters you checked are reset.
 - ◆ To reset all counters in a page, select the **Reset All** button.
-

Refreshing the Trace Counter display

When you open the Trace Counter window, you see the current values for all counters. Once opened, however, the counter information is updated only upon command. To update counter values, you must refresh the view manually.

TO UPDATE NERVECENTER TRACE COUNTERS ONCE THE WINDOW IS OPENED

- ◆ Select the **Refresh** button.
All counters are updated.
-

Table B-1 provides a reference for all procedures related to the trace counters. Each of these procedures are performed within a NerveCenter Administrator after it is connected to a NerveCenter Server

TABLE B-1. Procedures Related to Trace Counters

Task	Procedure
To view the trace counters...	From the Server menu, choose Trace Counts .
To view a specific counter...	Within the Trace Counters window, select the appropriate tab.
To reset one or more counters...	After selecting each of the relevant Reset checkboxes, select Reset .
To reset all the counters in a page...	Select Reset All .
To update all the counters...	Select Refresh .

Alarm Action Counters

The Action tab of the Trace Counters window provides read-only information about the current NerveCenter Server's automated actions. See [Using Trace Counters to Troubleshoot NerveCenter on page 273](#) for more information about using the counters.

TABLE B-2. Alarm Action Counters

Group	Field	Description
Specific action	Action Type	Select the type of action you want to monitor.
	Requested	The number of specified actions that have been requested.
	Pending	The number of specified actions that are pending.
Totals for All Actions	Completed	The number of specified actions that are completed.
	Requested	The total number of all actions that NerveCenter has requested (as opposed to the number of actions for the selected action type).
	Pending	The total number of all actions that are currently pending.
	Completed	The total number of all actions that have been completed.

Database Counters

The Database tab of the Trace Counters window provides read-only information about the current NerveCenter Server's automated actions. See [Using Trace Counters to Troubleshoot NerveCenter on page 273](#) for more information about using the counters.

TABLE B-3. Database Counters

Group	Field	Description
DB Operations	Successful	The number of NerveCenter operations that have been written to the database.
	Pending	The number of database entries waiting to be written.
DB Connections	Lost	The number of lost connections with the database.
	Restored	The number of lost connections with the database that were later restored.

Inform Counters

The Inform tab of the Trace Counters window provides read-only information about the current NerveCenter Server's automated actions. See [Using Trace Counters to Troubleshoot NerveCenter on page 273](#) for more information about using the counters.

TABLE B-4. Inform Counters

Group	Field	Description
OVPA	Requested	The number of informs requested to be sent to the NerveCenter OpenView Platform Adapter.
	Sent	The number of informs that have been sent to the NerveCenter OpenView Platform Adapter.
	Pending	The number of informs saved in the queue and waiting to be sent to NerveCenter's OpenView Platform Adapter.
OPC	Requested	The number of informs requested to be sent to NerveCenter's SEMSOPCA adapter.
	Sent	The number of informs that have been sent to NerveCenter's SEMSOPCA adapter.
Universal PA	Requested	The number of informs requested to be sent to NerveCenter's Universal Platform Adapter.
	Sent	The number of informs that have been sent to NerveCenter's Universal Platform Adapter.

Inform NerveCenter Counters

The Inform NC tab of the Trace Counters window provides read-only information about the current NerveCenter Server's automated actions. See [Using Trace Counters to Troubleshoot NerveCenter on page 273](#) for more information about using the counters.

TABLE B-5. Inform NerveCenter Counters

Field	Description
Received	The number of informs the current NerveCenter Server has received from other NerveCenter Servers.

TABLE B-5. Inform NerveCenter Counters

Field	Description
Processed	The number of informs the current NerveCenter Server has received and processed from other NerveCenter Servers.

Log to Database Counters

The Log DB tab of the Trace Counters window provides read-only information about the current NerveCenter Server's automated actions. See [Using Trace Counters to Troubleshoot NerveCenter on page 273](#) for more information about using the counters.

TABLE B-6. Log to Database Counters

Field	Description
Requested	The number of Log to Database actions requested.
Pending	The number of Log to Database actions that are still pending.
Lost	The number of Log to Database actions that did not successfully log and are considered to be lost.
Deleted	The number of Log to Database actions that did not successfully log and have been removed from the log queue.

Log to File Counters

The Log File tab of the Trace Counters window provides read-only information about the current NerveCenter Server's automated actions. See [Using Trace Counters to Troubleshoot NerveCenter on page 273](#) for more information about using the counters.

TABLE B-7. Log to File Counters

Field	Description
Requested	The number of Log to File actions requested.
Pending	The number of Log to File actions that are still pending.
Lost	The number of Log to File actions that did not successfully log and are considered to be lost.
Deleted	The number of Log to File actions that have been removed from the log file.

Server Counters

The Server tab of the Trace Counters window provides read-only information about the current NerveCenter Server's automated actions. See [Using Trace Counters to Troubleshoot NerveCenter on page 273](#) for more information about using the counters.

TABLE B-8. Server Counters

Field	Description
Alarms transitioned	The number of alarm instances that the current NerveCenter Server has transitioned.
Messages to client	The number of messages the current NerveCenter Server has sent to a connected NerveCenter Client.
Client connections	The number of NerveCenter Clients that have connected to the current NerveCenter Server.
Web connections	The number of NerveCenter Web Clients that have connected to the current NerveCenter Server.

Node Source Counters

The Node Source tab of the Trace Counters window provides read-only information about the current NerveCenter Server's automated actions. See [Using Trace Counters to Troubleshoot NerveCenter on page 273](#) for more information about using the counters.

TABLE B-9. Node Source Counters

Field	Description
Nodes received	The total number of nodes that NerveCenter has received from a node source and stored in its database. received during the last resync
Nodes updated	The total number of updates that NerveCenter has received from a node source during the last resync.
New nodes created	The number of nodes added to the NerveCenter node list when nodes were added to the network management platform.
Nodes auto deleted	The number of nodes removed from the NerveCenter node list.

OPC Msg Counters

The OPC Msg tab of the Trace Counters window provides read-only information about the current NerveCenter Server's automated actions. See [Using Trace Counters to Troubleshoot NerveCenter on page 273](#) for more information about using the counters.

TABLE B-10. OPC Msg Counters

Field	Description
Msgs received	The number of messages that the current NerveCenter Server has received from HP IT/Operations.
Msgs processed	The number of HP IT/Operations messages that the current NerveCenter Server has processed through an OpC mask.

Poll Counters

The Poll tab of the Trace Counters window provides read-only information about the current NerveCenter Server's automated actions. See [Using Trace Counters to Troubleshoot NerveCenter on page 273](#) for more information about using the counters.

TABLE B-11. Poll Counters

Group	Field	Description
SNMP	Requests	The number of SNMP polls requested.
	Pending	The number of polls waiting for an SNMP reply poll request.
	Responses Received	The number of SNMP responses that have been received from SNMP requests.
	Error Received	The number of SNMP and ICMP errors resulting from SNMP requests.
	Polls Retried	The number of SNMP polls that were reissued.
	Polls Timed Out	The number of SNMP polls that did not receive a response and therefore timed out.
ICMP	Requests	The number of ICMP polls requested.
	Pending	The number of polls waiting for an ICMP reply to the poll request.

TABLE B-11. Poll Counters (Continued)

Group	Field	Description
	Responses	The number of ICMP responses that have been received from ICMP requests.
	Error Received	The number of ICMP errors resulting from ICMP requests: The following types of messages indicate errors: ICMP_UNREACH, ICMP_SOURCEQUENCH, ICMP_REDIRECT, ICMP_TIMXCEED, ICMP_PARAMPROB.
	Polls Retried	The number of ICMP polls that were reissued.
	Polls Timed Out	The number of ICMP polls that did not receive a response and therefore timed out.

Trap Counters

The Trap tab of the Trace Counters window provides read-only information about the current NerveCenter Server's automated actions. See [Using Trace Counters to Troubleshoot NerveCenter on page 273](#) for more information about using the counters.

TABLE B-12. Trap Counters

Field	Description
Received	The number of SNMP traps that the current NerveCenter Server has received and processed.
Failed	The number of SNMP traps that the current NerveCenter Server has received but was unable to process.
Ignored	The number of SNMP traps that the current NerveCenter Server has received but ignored. NerveCenter ignores traps if NerveCenter is configured not to process traps from unknown nodes and the node sending the trap is outside NerveCenter's specified IP subnet filter range.

Trigger Counters

The Trigger tab of the Trace Counters window provides read-only information about the current NerveCenter Server's automated actions. See [Using Trace Counters to Troubleshoot NerveCenter on page 273](#) for more information about using the counters.

TABLE B-13. Trigger Counters

Field	Description
Masks	The number of triggers that NerveCenter has fired from trap masks.
OpC Masks	The number of triggers that NerveCenter has fired from OpC masks.
Actions	The number of triggers that NerveCenter has fired from alarm actions.
Polls	The number of triggers that NerveCenter has fired from polls.
Total	The total number of triggers that NerveCenter has fired.

Troubleshooting ASN.1 files

Many mibcomp error messages are caused by problems with ASN.1 MIB files. This section describes how to make sure your ASN.1 files can be processed correctly by the mibcomp utility and how to correct common ASN.1 errors. If you receive mibcomp error messages, check your ASN.1 files for the following possible problems:

- ◆ Improper characters
- ◆ Improper use of period, underscore, and hyphen
- ◆ Improper capitalization
- ◆ Improper table construction
- ◆ Duplicate type definitions
- ◆ Object identifier format
- ◆ Ignored **IMPORT** definitions

Use of characters

Blank spaces, carriage returns (^M), and line feeds (^J) are considered white space, used only as separators.

The following are the only characters you can use in ASN.1:

```
abcdefghijklmnopqrstuvwxyz
ABCDEFGHIJKLMNOPQRSTUVWXYZ
0123456789
:=, { } < > . ( ) [ ] - ' " ; |
```

Except in a comment, you cannot use the following characters:

```
!@#$%^&* _+~`?/
```

Note the following exceptions:

- You can use any character in a comment.
- An object name can have only alphabetic and numeric characters and hyphens (but never two hyphens in a row), and cannot end with a hyphen.

Period, underscore, and hyphen

The only nonalphanumeric character you can use in a type or value is the hyphen (-). Do not use a period (.) or an underscore (_).

Two consecutive hyphens (--) begin comments. Two consecutive hyphens or the end of a line can end comments. When you end a comment with a second pair of hyphens, mibcomp tries to convert the material between the second pair of hyphens and the end of the line. For example, given the following line:

```
-- This is a comment -- This is not a comment.
```

The mibcomp utility tries to convert “This is not a comment.” Don’t use two consecutive hyphens in an object name.

Capitalization

Key words and predefined types must contain only uppercase letters and must not be reserved character sequences. Reserved character sequences are listed below:

TABLE B-14. Reserved character sequences

ABSENT	DEFINED	INTEGER	REAL
ANY	DEFINITIONS	MAX	SEQUENCE
APPLICATION	END	MIN	SET
BEGIN	ENUMERATED	MINUS-INFINITY	SIZE
BIT	EXPLICIT	NULL	STRING
BOOLEAN	EXPORTS	OBJECT	TAGS
BY	EXTERNAL	OCTET	TRUE
CHOICE	FALSE	OF	UNIVERSAL

TABLE B-14. Reserved character sequences

COMPONENT	FROM	OPTIONAL	WITH
COMPONENTS	IDENTIFIER	PLUS - INFINITY	
correct	IMPLICIT	PRESENT	
DEFAULT	INCLUDES	PRIVATE	

Type references and type declarations must begin with an uppercase letter.

Enumeration names, value names, and object identifiers must begin with a lowercase letter.

Table construction

If a table isn't being displayed properly, it might be missing an **INDEX** clause or a **SEQUENCE** definition. An **INDEX** clause looks like this:

```
INDEX(instance)  
    ::= (parent)
```

A **SEQUENCE** definition for each table in the ASN.1 file is necessary for compliance with RFC1212. For example, a MIB might have:

```
commonB    OBJECT IDENTIFIER ::= { rr2board 1 }  
boardIndex OBJECT-TYPE  
SYNTAX INTEGER  
ACCESS read-only  
STATUS mandatory  
DESCRIPTION  
    "The slot number of this board."  
 ::= { commonB 1 }  
  
.  
.  
.  
etc.
```

This prevents the mibcomp utility from producing usable output because it cannot detect that boardIndex is an attribute of a tabular object. One way to fix this is to add extra material between commonB and the first attribute, as follows:

```
commonB OBJECT IDENTIFIER ::= { rr2board 1 }
-- -- Modified for 1212 compliance --
commonB OBJECT-TYPE
SYNTAX CommonB
ACCESS read-write
STATUS mandatory
INDEX { boardIndex }
:= { rr2board 1 }
CommonB ::= SEQUENCE {
boardIndex
INTEGER,
boardName
OCTET STRING,
boardType
INTEGER,
boardTotalPorts
INTEGER,
boardStatus
INTEGER,
boardPortsOn
INTEGER }
boardIndex OBJECT-TYPE
SYNTAX INTEGER
ACCESS read-only
STATUS mandatory
DESCRIPTION
"The slot number of this board."
:= { commonB 1 }
.
.
etc.
```

Do not nest tables. Nesting can happen indirectly—for example, when a type that contains a table is referenced in a table without the connection being obvious. To avoid nesting, you can use an index from one table to index another.

Duplicate type definitions

If the `mibcomp` utility encounters duplicate type definitions, it uses the first definition it encounters and then displays the following message:

```
Warning(file.asn1:about line n):
Duplicate type defined: TypeName
```

It then continues processing without pausing for you to respond. Make sure the type definitions are all the same, or rename the types and use `mibcomp` again.

Object identifier format

The only object identifier format `mibcomp` accepts is:

```
{objname integer}
```

Any other format results in the error message:

```
Illegal Object Identifier Value
```

If your MIB contains an object identifier like:

```
open OBJECT IDENTIFIER ::= { osi 1 2 }
```

you could change it to an acceptable object identifier by splitting the definition as follows:

```
open OBJECT IDENTIFIER ::= { osi 1 }
open OBJECT IDENTIFIER ::= { osi 2 }
```

Ignored IMPORT definitions

The `mibcomp` utility ignores the **IMPORT** definition.

For example,

```
MIB-A: x = 1
MIB-B: x = 2
MIB-C: import x from MIB-B
```

In MIB-C, the utility takes `x` as 2 rather than as 1 if MIB-A is parsed first. Before parsing, check for **IMPORT** clauses and copy the **IMPORT** definitions directly into the MIBs containing them.

Controlling NerveCenter from the Command Line

NerveCenter provides commands that you can run from a UNIX shell or a DOS Command Prompt window. NerveCenter also enables you to run a command line interface (CLI) from which you can issue single commands, open a CLI interactive session, or run a CLI script.

This appendix includes the following sections:

Section	Description
<i>NerveCenter Command Line Interface on page 289</i>	Describes the NerveCenter command line interface (CLI) and how to use it.
<i>NerveCenter UNIX Shell/DOS Prompt Commands on page 294</i>	Describes the NerveCenter commands that you can execute from a UNIX shell or a Windows command prompt.
<i>Command Line Interface Reference on page 331</i>	Describes the NerveCenter commands that you can execute from the command line interface (CLI).

NerveCenter Command Line Interface

You can use a command line interface (in a UNIX shell or a DOS Command Prompt window) to list, delete, and control nodes, alarms, polls, and masks. You can also connect to, display the status of, and disconnect from NerveCenter servers — either manually or from a script.

The following sections describe how to control NerveCenter from the command line:

- ◆ *Entering a Single Command in a UNIX Shell or a DOS Prompt on page 290*
- ◆ *Entering Multiple Commands in an Interactive Session on page 291*
- ◆ *Running a script that contains one or more commands on page 292*

For information about specific commands, see the section *Command Line Interface Reference on page 331*. The procedures in this appendix assume that you are in the NerveCenter bin directory or that your search path includes that directory. NerveCenter installation includes this directory in your search path by default.

Entering a Single Command in a UNIX Shell or a DOS Prompt

TO ISSUE A SINGLE COMMAND IN A UNIX SHELL OR AT A DOS PROMPT

1. Open a UNIX shell or a DOS Command Prompt window.
2. Type

```
nccmd -s ServerName -u UserName -p Password -n Port Command
```

where *ServerName* is the name of the server you want to contact, *UserName* and *Password* are valid for that NerveCenter server, *Port* is the command-line-interface port (32506 by default), and *Command* is the command you want to run. Then press Enter.

**NOTE**

The user ID and password are encrypted before they are sent over the network.

If you are already connected to a server via a previous connect or select server command, the command you issue is directed to that server, and the -s switch is unnecessary.

The command is executed and informs you if an error was encountered. The command syntax is specified in [Command Line Interface Reference on page 331](#).

In the following example, a user named John lists all the polls that are suppressed. For this example, the server is named sales, John's user ID is johndoe, and his password is anytown.

```
nccmd -s sales -u johndoe -p anytown -n 32506 list poll -S yes
```

Entering Multiple Commands in an Interactive Session

TO OPEN AN INTERACTIVE SESSION AND ENTER MULTIPLE COMMANDS

1. Open a UNIX shell or a DOS Command Prompt window.
 2. Do one of the following:
 - ♦ To open a session without connecting directly to a server, type **nccmd** and press Enter.
The nccmd command prompt (nc>) appears.
 - ♦ To open an interactive session and connect directly to a server, type

```
nccmd -s ServerName -u UserName -p Password -n Port
```

where *ServerName* is the name of the NerveCenter server you want to contact, *UserName* and *Password* are a valid for that NerveCenter server, and *Port* is the server's command-line-interface port (32506 by default). Then press Enter.
The nccmd command prompt (nc>) appears and you are connected to the server.
All subsequent commands are sent to that server until you connect to an additional server or issue a select server command.
 3. Type the commands you want to run, pressing Enter after each one.
The command syntax is specified in [Command Line Interface Reference on page 331](#).
Each time you press Enter, you are returned to the nccmd command prompt. If any command returns an error, nccmd quits, returns you to the shell prompt or the Command Prompt, and displays the error.
 4. To exit the interactive session, type **quit** at the prompt and press Enter.
You are returned to a shell or command Prompt.
-

In the following example, a user named Kim opens an interactive session, connects directly to the server, deletes a node, disconnects from the server, and quits the session. For this example, the server is named sales, Kim's user ID is kimz, her password is NoMuZak, and the name of the node she is deleting is N0128.

```
C:\>nccmd -s sales -u kimz -p NoMuZak -n 32506
nc>delete node -n N0128
nc>disconnect
nc>quit
```

Running a script that contains one or more commands

TO RUN A SCRIPT THAT CONTAINS ONE OR MORE COMMANDS

1. Create a text file that contains the commands in the order you would enter them as if you were in an interactive session.

The command syntax is specified in *Command Line Interface Reference on page 331*.

2. Open a DOS Command Prompt window or a UNIX shell.
3. Do one of the following:
 - ◆ To connect to a NerveCenter server and have the server execute the commands in your file, enter a command of the following form:

```
nccmd -s ServerName -u UserName -p Password -n Port -f  
Filename
```

ServerName is the name of the NerveCenter server you want to contact, *UserName* and *Password* are a valid user name and password for that NerveCenter server, *Port* is the command-line-interface port for the server (32506 by default), and *Filename* is the name of the file containing the commands you want to run.



NOTE

If *Filename* is a file name or path name that contains spaces, the name must be enclosed in quotation marks, for example, "C:\Program Files\OpenService Software\NerveCenter\Bin\Cmd.nc".

- ◆ To prevent having to connect to the server explicitly each time you want to run your script, you can edit your script so that its first line is a connection command. This command must have the form:

```
connect -s ServerName -u UserName -p Password -n Port
```

Once you've performed this step, you can type **nccmd -f *Filename*** from the DOS or a shell prompt to connect to the server and execute the commands in your script.

If any command returns an error, nccmd quits, displays the error, and returns you to the Command Prompt or UNIX prompt.

In the following example, a user named Juan writes a script that connects to a server, turns on an alarm named Monitor, and disconnects from the server. For this example, the server is named sales, Juan's user ID is juanr, and his password is CaFFieNe. The script is named SetAlarm and it looks like this:

```
connect -s sales -u juanr -p CaFFieNe -n 32506
set alarm -e on -w -a Monitor
disconnect -s sales
```

Juan runs the script by entering the following command at the command prompt:

```
>nccmd -f SetAlarm
```

NerveCenter UNIX Shell/DOS Prompt Commands

There are certain NerveCenter commands that you run from a UNIX shell or a Windows command prompt. This section lists each of these commands in alphabetical order:

- ◆ *client on page 295*
- ◆ *dbwizard on page 295*
- ◆ *importutil on page 296*
- ◆ *installdb on page 306*
- ◆ *ipsweep on page 308*
- ◆ *mibcomp on page 310*
- ◆ *ncadmin on page 312*
- ◆ *nccmd on page 312*
- ◆ *ncserver on page 314*
- ◆ *ncstart on page 315*
- ◆ *ncstop on page 316*
- ◆ *ovpa on page 317*
- ◆ *paserver on page 321*
- ◆ *semsopca on page 324*
- ◆ *serializedb on page 325*
- ◆ *trapgen on page 326*



NOTE

This appendix assumes that you are in the NerveCenter bin directory or that your search path includes that directory. NerveCenter installation includes this directory in your search path by default.

client

NAME

client

SYNOPSIS

```
client
```

DESCRIPTION

Executes the NerveCenter Client application. For information about how to use NerveCenter Client, refer to *Designing and Managing Behavior Models* and *Monitoring Your Network*.

USAGE

If you receive the error message client: Command not found on a UNIX system, NerveCenter has not been installed in the default location (/opt/OSInc). You must either navigate to the NerveCenter bin directory before entering the command, or use a fully-qualified pathname.

**NOTE**

On UNIX, before you can run NerveCenter, you must first set the necessary environment variables by running the appropriate ncenv shell script. For more information see *Running the NerveCenter Server on UNIX on page 38*.

SEE ALSO

ncstop on page 316

dbwizard

NAME

dbwizard

SYNOPSIS

```
dbwizard
```

DESCRIPTION

A wizard that helps you to create a NerveCenter Microsoft Access or SQL Server database.

USAGE

InstallDB is the command-line version of DBWizard. If you are installing NerveCenter on many computers, you can use the wizard to set up the first database, save your configuration settings, and use them with the command-line version of DBWizard to save time on subsequent setup routines.

SEE ALSO

installdb on page 306

importutil

NAME

importutil

SYNOPSIS

```
importutil imputil.ini
```

DESCRIPTION

Enables you to reconfigure a setting on more than one NerveCenter Server at a time by changing one file and importing it to all the relevant servers.

OPTIONS

```
imputil.ini
```

File that contains NerveCenter Server settings that you import to all NerveCenter Servers. imputil.ini resides in the /userfiles directory .

USAGE

imputil.ini is made of a number of sections that include a section header and keys. Before making any changes, create a backup copy of imputil.ini.

**CAUTION**

You will not be able to restore the original imputil.ini after making changes to the file, unless you first make a backup copy.

Delete all but the relevant sections to be changed.

All sections in the file are optional. If you remove a section, including the section header and keys, ImportUtil does not change or delete values in the NerveCenter configuration settings for that key.

For example, if you are changing a value found only in the section [CONFIG_SERVER], you delete all sections except the section header and the values in the [CONFIG_SERVER] section. ImportUtil will only change the values pertaining to that section.

Any new values left in imputil.ini will overwrite the old values. To avoid having placeholders overwrite legitimate values, delete any unnecessary keys before running ImportUtil.

For example, if within the [CONFIG_SERVER] section you only want to change the value of the key InformNCListenPort, delete all but the following:

```
[CONFIG_SERVER]
InformNCListenPort = port
```



CAUTION

If you are configuring either [CONFIG_PLATFORM_NETNODENOTIFY] or [CONFIG_PLATFORM_MAPSUBNETS], you need to include all values, including old values. ImportUtil deletes values from the NerveCenter configuration settings that are not included in these sections. Please read the comments before each section in this file for more information.

Change the values by replacing the placeholders after the equal sign (=) with valid values. Unless otherwise noted, you may not leave the value after a key blank.



NOTE

You must either be in the same directory as the imputil.ini file or include the full pathname of the imputil.ini file.

NerveCenter notifies you upon successful completion of the reconfiguration. For more information about each section in imputil.ini, refer to [Table C-1](#).

TABLE C-1. imputil.ini Value Descriptions

imputil.ini value pair	Description
[CONFIG_PLATFORM]	
	This section configures integrations with network management platforms.
	To remove a value, leave the value after the equal sign (=) blank. For example: MapHost=
	Note: Except for OpCHost, the cross-references in this section refer to integrating with HP OpenView. You may need to review the chapter in <i>Integrating NerveCenter with a Network Management Platform</i> appropriate for your network management platform.

TABLE C-1. inputil.ini Value Descriptions (Continued)

inputil.ini value pair	Description
MapHost = host/port/resyncparentrate	These are the hostname, port, and resync Parent rate defined on the Node source tab. For more details about this value, see <i>Identifying Parent-Child Relationships in Integrating NerveCenter with a Network Management Platform</i>
OpCHost = host/port	The hostname and port number of the IT/Operations machine. For more details about this value, see <i>Specifying the Destination of NerveCenter Inform Packets sent to HP OpenView IT/Operations in Integrating NerveCenter with a Network Management Platform</i> .
Method = Auto Manual	When the method is set to Automatic, NerveCenter ignores your address filters. It looks at the IP address and mask for each network interface card on that server and uses them to calculate the subnet address and mask. Enter Manual if you want NerveCenter to use your address filters as entered. For details see <i>Filtering Nodes by IP Address on page 105</i>
WantedCapabilities = cap1,cap2,...	<p>You can monitor nodes with particular capabilities, which your network management system typically assigns to a node to determine the applicable activities such as isRouter, isHub, and isIP.</p> <p>Filtering by capabilities is available only when your platform has assigned specific capabilities to a node.</p> <p>For more details about this value, see <i>Filtering Using a Node's Capabilities on page 103</i>.</p>
SystemObjectIds = id1,id2,...	NerveCenter allows you to monitor managed nodes according to their particular system object identifiers (OIDs). For more details about this value, see <i>Filtering Using a Node's System Object Identifier on page 104</i> .
MaxQueueDepth = maximum queue depth	The number of Informs NerveCenter keeps if connection with the network management platform goes down. For more details about this value, see <i>How to Configure the Inform Queue Depth in Integrating NerveCenter with a Network Management Platform</i>

TABLE C-1. imputil.ini Value Descriptions (Continued)

imputil.ini value pair	Description
AckInforms = 0/1	If you want NerveCenter to keep track of informs until the platform adapter acknowledges their receipt, you must enable the inform acknowledgement feature by setting AckInforms = 1. For more details about this value, see <i>How to Save NerveCenter Informs until Acknowledgement in Integrating NerveCenter with a Network Management Platform</i> .
NoFiltersOnImport = 0/1	If you have a node list you want to import of known hosts you want to monitor, you may not want to apply the IP and Hostname filters. Enter 0 for false and 1 for true. For more details about this value, see <i>Enabling and Disabling IP and Hostname Filters on page 111</i> .
HostnameFilters = hostname1 *hostname2 . . .	Besides IP addresses, you can also filter by hostnames. For more details about this value, see <i>Filtering Nodes by Hostnames on page 110</i> .
[CONFIG_PLATFORM_MAPSUBNETS]	
This section configures the IP filtering for node lists imported from a network management platform. If the method in [CONFIG_PLATFORM] is AUTO, the entries in this section are ignored.	
Caution: You must include all values from this section, including old values. ImportUtil deletes values from the NerveCenter configuration settings that are not included in these sections.	
Note: If you want to apply filters to a list of nodes you are importing, first run importutil to change the filters. Then run importutil again to import the nodes.	
MapSubNet1 = Address;Mask;Exclusion list	You can filter nodes by subnet. For more details about this value, see <i>Filtering Nodes by IP Address on page 105</i> .
MapSubNet2 = Address;Mask;Exclusion list	

TABLE C-1. inputil.ini Value Descriptions (Continued)

inputil.ini value pair	Description
[CONFIG_PLATFORM_NETNODENOTIFY]	
This section configures what information NerveCenter sends to the Network Management Platform.	
<p>Caution: You must include all values from this section, including old values. ImportUtil deletes values from the NerveCenter configuration settings that are not included in these sections.</p>	
<p>Note: The cross-references in this section refer to integrating with HP OpenView. You may need to review the chapter in <i>Integrating NerveCenter with a Network Management Platform</i> appropriate for your network management platform.</p>	
host/port/type = EVENT_ONLY EVENT_AND_SYMBOL SYMBOL_ONLY [Min Severity] [Properties]	<p>The type of information sent to the network management platform. For more details about these values, see <i>Sending NerveCenter Informs to HP OpenView Network Node Manager in Integrating NerveCenter with a Network Management Platform</i>.</p> <p>Note: Type must be either OVPA or PA_SVR</p>
[CONFIG_SERVER]	
This section configures the NerveCenter Server.	
ServerConnPort = port	<p>The NerveCenter Server communicates with other applications, such as NerveCenter Client and NerveCenter Administrator, on a special connection port. For more details about this value, see <i>Configuring the NerveCenter Server Connection Port on page 80</i>.</p> <p>If you change a NerveCenter Server's communication port number, be sure all applications, such as NerveCenter Administrator, have a matching port number. See <i>Changing the NerveCenter Administrator's Server Port on page 82</i> for more details.</p>
CLICConnPort = port	<p>The port number you want the NerveCenter Server to use for client/server communication. For more details about this value, see <i>Changing the NerveCenter Client's Server Port on page 83</i>.</p>

TABLE C-1. inputil.ini Value Descriptions (Continued)

inputil.ini value pair	Description
InformNCListenPort = port	Before a NerveCenter Server can receive an Inform, it must be configured to have a listening port number. For more details about this value, see <i>Configuring NerveCenter to Receive Inform Actions on page 84</i> .
LicenseKey = key	The license key or serial number for NerveCenter. For more details about this value, see <i>Working with NerveCenter Serial Numbers on page 62</i> .
NCMibName = MibName	The filename of the mib file you want to import into NerveCenter. You enter the path in [CONFIG_SERVER_PATH]. For more details about this value, see <i>Configuring NerveCenter to Use the New MIB on page 237</i> .
EnableDiscovery = TRUE FALSE	If true, NerveCenter adds nodes discovered by traps to the database. For more details about this value, see <i>Adding Nodes Discovered from Traps on page 125</i> .
DiscoverNodesFromTraps = All Filter None	For more details about this value, see <i>Populating Using the IPSweep Behavior Model on page 119</i> .

TABLE C-1. inputil.ini Value Descriptions (Continued)

inputil.ini value pair	Description
OVTrapperPath = MSTRAP OVTRAPD NCNOMSTRAP NCNOOVTRAP ALWAYS NCNEVER NCALWAYS	<p>Windows:</p> <ul style="list-style-type: none"> ◆ MSTRAP - traps are received from Microsoft SNMP Trap Service. ◆ OVTRAPD - traps are received via ovtrapper from HP OpenView. ◆ NCNOMSTRAP - traps are received via the NerveCenter SNMP Trap agent. Use if NerveCenter is <i>not</i> co-resident with HP OpenView. ◆ NCNOOVTRAP - traps are received via the NerveCenter SNMP Trap agent. Use if NerveCenter is co-resident with HP OpenView. <p>UNIX:</p> <ul style="list-style-type: none"> ◆ ALWAYS - traps are received via ovtrapper from HP OpenView ◆ NCNEVER - traps are received via the NerveCenter SNMP Trap agent. Use if NerveCenter is <i>not</i> co-resident with HP OpenView. ◆ NCALWAYS - traps are received via the NerveCenter SNMP Trap agent. Use if NerveCenter is co-resident with HP OpenView. <p>For more details about this value, see <i>The OpenView Platform Adapter in Integrating NerveCenter with a Network Management Platform</i>.</p>
useOvTrapd = MSTRAP OVTRAP	The NerveCenter trap source. For more details about this value, see <i>Managing the NerveCenter Trap Source on page 54</i> .

TABLE C-1. imputil.ini Value Descriptions (Continued)

imputil.ini value pair	Description
ApplyAllMasksForEachTrap = TRUE FALSE	Set to TRUE if you want NerveCenter to process every incoming SNMP trap against all defined trap masks that are currently enabled. Selecting this option forces masks to process traps regardless of the state of their associated alarms. A mask processes traps even when its associated alarm is turned off or is not in a state that can be transitioned by the mask's trigger. There are times, however, when masks do not process traps though this option may be checked. A mask processes traps only when the following conditions are met: <ul style="list-style-type: none"> ◆ The mask is turned on. ◆ The incoming trap matches the generic, specific, or enterprise OID values defined in the mask.
[CONFIG_SERVER_PATH]	
Path information.	
MibDirectory = Location of Mib	The path to the mib file you want to import into NerveCenter. You enter the filename in [CONFIG_SERVER]. For more details about this value, see Configuring NerveCenter to Use the New MIB on page 237 .
LogDirectory = Location of logs	The location of any log created by a Behavior Model or other component of NerveCenter. For details about this value, see Specifying Settings for Log Management on page 194 .
[CONFIG_SERVER_PAGER]	
This section configures the paging properties.	
TouchPulse =	Enter the frequency. Default is 1200. For details about this value, see Setting Dialing Properties for Paging Notification on Windows on page 190 .
DialOutNumber =	The number required to reach an outside line, for example, 9. For details about this value, see Setting Dialing Properties for Paging Notification on Windows on page 190 .
PauseString =	The characters used to create a pause between dialing and sending data. For details about this value, see Setting Dialing Properties for Paging Notification on Windows on page 190 .
[CONFIG_SERVER_SNMP]	
This section configures SNMP settings.	

TABLE C-1. inputil.ini Value Descriptions (Continued)

inputil.ini value pair	Description
SnmpRetry = No. of retries	The number of times to reissue unanswered SNMP or ICMP request polls. For more details about this value, see Specifying SNMP Poll Intervals for NerveCenter on page 147 .
SnmpInterval = No. of Intervals	The number of seconds NerveCenter should wait for a reply to a poll before issuing another. For more details about this value, see Specifying SNMP Poll Intervals for NerveCenter on page 147 .
DefaultPort = port no.	The port number NerveCenter uses for SNMP traps. For more details about this value, see Specifying SNMP Ports for NerveCenter on page 88 .
[CONFIG_SERVER_SNMPV3]	
This section configures the SNMP v3 settings.	
PollUser = poll user	The SNMP v3 user name. For more details about this value, see Changing the NerveCenter SNMP v3 User Name and Context on page 157 .
PollContext = poll context	The SNMP v3 context. For more details about this value, see Changing the NerveCenter SNMP v3 User Name and Context on page 157 .
AutoClassify = on off	Whether NerveCenter attempts to classify the SNMP format of discovered nodes. For more details about this value, see Classifying Nodes Automatically on page 143 .
AuthPwd = unencrypted (plain text) authentication password (min 8 chars and max 32 chars)	The Authentication password for an SNMP v3 node. For more details about this value, see Changing the SNMP v3 Key Passwords on page 155 .
PrivPwd = unencrypted (plain text) privacy password (min 8 chars and max 32 chars)	The Privacy password for an SNMP v3 node. For more details about this value, see Changing the SNMP v3 Key Passwords on page 155 .
MaxClassifyVer = v1 v2c v3	If autotclassification is enabled, you can limit to what level NerveCenter attempts to classify nodes. For more details about this value, see Setting a Maximum Classify Value on page 145 .

TABLE C-1. imputil.ini Value Descriptions (Continued)

imputil.ini value pair	Description
MaxReqPerCycle = Max no. of requests going out of v3opmanager per second	You control SNMP v3 performance by setting a maximum number of requests per processing cycle (approximately one second) for all v3 operations including classification, SNMP test version poll, version change, authentication protocol change, security level change, and initialization requests. For more details about this value, see <i>Setting the Maximum SNMP v3 Requests per Cycle on page 146</i> .
updateKeys = T F	To update the passwords on all managed agents, enter T. For more details about this value, see <i>Changing the SNMP v3 Key Passwords on page 155</i> .
[CONFIG_SERVER_LOGS]	
This section configures the NerveCenter Logs.	
MaxLogEntryAge =	The number of hours you want to keep individual log entries before they are deleted from the rest of the log. For more details about this value, see <i>Specifying Settings for Log Management on page 194</i> .
MaxLogFileSize =	The size limit, in kilobytes, of the ASCII text file storing the results of the Log to File alarm action. For more details about this value, see <i>Specifying Settings for Log Management on page 194</i> .
MaxNumDBRecords =	The highest number of records in the database file storing the results of the Log to Database alarm action. For more details about this value, see <i>Specifying Settings for Log Management on page 194</i> .
LogDelPercentage =	The percentage of the log to clear when the maximum file size or the maximum number of records is reached. For more details about this value, see <i>Specifying Settings for Log Management on page 194</i> .
MaxQueueDepth =	The highest number of changes that you want queued before saving to the database. For more details about this value, see <i>Specifying Settings for Log Management on page 194</i> .
[CONFIG_SERVER_MSMAIL]	
This section configures Microsoft Mail.	

TABLE C-1. inputil.ini Value Descriptions (Continued)

inputil.ini value pair	Description
Profile =	The NerveCenter-designated Exchange profile to point to the machine hosting the Microsoft Exchange Server and the NerveCenter-designated mailbox created in <i>Configuring NerveCenter to Send Microsoft Mail on page 184</i> .
Password =	The password to the NerveCenter-designated mailbox created in <i>Configuring NerveCenter to Send Microsoft Mail on page 184</i> .
[CONFIG_SERVER_SMTPMAIL]	
This section configures SMTP mail.	
SMTPHost =	The name of the host running your SMTP mail server. For more details about this value, see <i>Specifying an SMTP Server for Mail Notification on page 182</i> .
[IMPORT_MODEL]	
Use this section to import a NerveCenter Behavior Model.	
File = model_path_and_filename	For more details about this value, see <i>Importing Node, Object, and Behavior Model Files in Designing and Managing Behavior Models</i> .
[IMPORT_NODE]	
Use this section to import a NerveCenter Node List.	
File = node_path_and_filename	For more details about this value, see <i>Importing Node, Object, and Behavior Model Files in Designing and Managing Behavior Models</i> .

installdb

NAME

installdb

SYNOPSIS

```
installdb -F IDBfile -O {f|l|c|r} -D {s|a} [-M {v|s}] [-H]
```

DESCRIPTION

Creates or modifies a NerveCenter Microsoft Access or SQL Server database.

OPTIONS

`-F IDBfile`

The path and file name for the IDB file (required).

`-O {f | l | c | r}`

Specifies the operation code (required). The choices are:

f—Full database creation and installation

l—Load serialized file

c—Create data source and connection string

r—Run SQL script

`-D {s | a}`

Specifies the database type (required). The choices are:

s—SQL

a—Access



NOTE

The SQL script can only run against a SQL database, not an Access database. If the operation parameter is *r* (run SQL script), then you must specify *s* (SQL) as the database type.

`[-M {v | s}]`

Specifies the mode of operation (optional). *v* is verbose, and *s* is silent. If **-M** is not specified, InstallDB defaults to *s* (silent).

`[-H]`

Displays usage help in a dialog box. You can also enter simply: **installdb**

USAGE

Command line switches in Windows are case-insensitive; you can type them in any order.

If any of the required command line switches are missing and the mode is *s* (silent), then an error is written to the Event Log. If mode is *v* (verbose), then an error message is displayed.

EXAMPLE

```
InstallDB -F c:\temp\dbwizard.idb -M v -O f -D s
```

ipsweep

NAME

ipsweep

SYNOPSIS

```
ipsweep [-d] [-trace] [-f excludefile] [-m mapfile] [-w mapfile]  
        [-notraps] [-t timedelay] [-ttl hops] | [-h]
```

DESCRIPTION

Discovers network devices on the subnets managed with NerveCenter. Ipsweep pings IP addresses according to filters set in the NerveCenter Administrator. If no filters are defined, ipsweep does not ping any IP addresses. If ipsweep receives a response from an IP address, ipsweep sends a SNMP v1 trap to NerveCenter. You must configure NerveCenter to automatically add nodes if a trap is received in order to update your node list. For more information about configuring NerveCenter to work with ipsweep, see [Populating Using the IPSweep Behavior Model on page 119](#) and [Using NerveCenter's IPSweep Behavior Model in Designing and Managing Behavior Models](#).

The NerveCenter Server must be running to use ipsweep.

OPTIONS

-d

Specifies debug mode and outputs verbose debug messages to the console.

-trace

Specifies trace mode and outputs status messages to the console.

-f *excludefile*

Specifies a file that contains a list of IP addresses for ipsweep to ignore.

-m *mapfile*

Specifies a map file that contains node information about the network.

IP Filters must still be configured in the NerveCenter Administrator's IP Filters page for each subnet that is discovered. The map file uses the subnet and mask value to match an existing pair in the IP Filters page. The Map file does not specify which subnets to discover. It just specifies the read community string used for a subnet if it is discovered.

`-w mapfile`

Writes a text file containing the read community string used for discovered subnets. You can then edit this file and use with `-m`.

`-notraps`

Specifies that no SNMPv1 Traps are sent. Useful with `-d` and `-trace` for debugging behavior without causing unnecessary notifications.

`-t timedelay`

ICMP timeout interval. *timedelay* is a value in milliseconds (default is 20 milliseconds).

`-ttl hops`

Specifies the time to live (TTL) value for IPSweep, where the valid value is between 0 and 255 hops. The default value for `-ttl` is: 255 hops (128 for Windows 2000).

`-h`

Provides command line help for ipsweep.

USAGE

Ipsweep can read an exclude file specified by the `-f` switch. This exclude file is parsed as follows:

- ◆ One IP Address can be listed on each line.
- ◆ The IP Address must be the first token in each line; there can be no leading white space.
- ◆ Any text or data following the IP Address is ignored.
- ◆ Each line cannot be more than 16 characters in length or else the entire line is ignored.
- ◆ Lines which are blank or do not contain a valid IP Address as the first token are ignored.
- ◆ An IP Address is considered valid only if it contains four octets, separated by periods (.), where each octet is in the range 0 (zero) to 255 inclusive.
- ◆ A hostname cannot be used in place of an IP Address; no lookup is performed to see whether a non-valid IP Address is actually a hostname.
- ◆ You can use comment labels, such as `#` or `;`, to comment your exclude file, for example:

```
# Private QA Router
168.192.13.194
# Printer
168.192.1.44
```

On startup, ipsweep can read a map file specified by the `-m` switch. This map file contains a table as follows:

Default *DefaultReadCommunity*

Subnet1/Mask1 ReadCommunity1

SubnetN/MaskN ReadCommunityN

The first line should be the ‘**Default** *DefaultReadCommunity*’ line. A single blank separates the word **Default** and the community string. Each of the lines following the Default line will be in the format specified above. These lines will be a Subnet immediately followed by a slash (“/”) immediately followed by the Mask. The “Subnet/Mask” is followed by a single blank and then the community string, for example:

```
192.168.1.0/255.255.255.0 private
```

mibcomp

NAME

mibcomp

SYNOPSIS

```
mibcomp [-trace] [-nocache] [-clean] {-help|-ver} mib-definition-file
```

DESCRIPTION

Compiles the NerveCenter management information base (MIB) with SNMP Research’s Bilingual Request and Security Subsystem (BRASS) SNMP MIB compiler utility suite.

After the first compilation, intermediary files are stored in *mib\cache* (Windows) or *mibs/cache* (UNIX), unless you use the *-nocache* argument.

OPTIONS

mib-definition-file

Name of the file that contains NerveCenter MIB definitions, the default is *mibcomp.txt*.

-trace

Gives a verbose output to monitor the process of compiling the *mib-definition-file*.

-nocache

Causes all MIB compilation to occur in *\$TMP/cache*.

-clean

Resets the compilation cache, stored in `mib/cache` (Windows) or `mibs/cache` (UNIX), and performs a complete recompilation of all MIB modules.

When removing entries from the `mibcomp.txt` file, you must run `mibcomp` with the `-clean` argument to remove the cached intermediary files.

`-help`

Displays description of arguments.

`-ver`

Displays `mibcomp` version information.

USAGE

By default, the NerveCenter MIB is `/mibs/nervectr.mib` (`\mib` on Windows). As with any compilation, it is always wise to make a backup copy of the `nervectr.mib`, `mibnamemap.txt`, and `mibcomp.txt` before running `mibcomp`; however, Open does provide backup files of the NerveCenter MIB and the MIB definition file shipped with NerveCenter, `/mibs/nervectr-release-number.mib` and `mibcomp-release-number.txt`, respectively.

`mibcomp` requires that you change to the `mibs` (`mib` on Windows) directory before compiling. As the `mibcomp` compiles the file, it displays a series of messages. If a problem needs your attention, the compilation fails. You must resolve the error and re-compile. The error is displayed on the last line on your screen. You will have to do this more than once if you have several errors. Errors are generally syntax problems in third-party MIBs or MIBs that do not comply with the RFC specification.



CAUTION

The MIB must be located on the machine hosting NerveCenter Server. Configure security on the machine so unauthorized users cannot overwrite or change the MIB.

You must reload the NerveCenter MIB after compiling it. See [Managing Management Information Bases \(MIBs\) on page 229](#) for more information.

ncadmin

NAME

ncadmin

SYNOPSIS

ncadmin

DESCRIPTION

Executes the NerveCenter Administrator application.

USAGE

On UNIX, if you receive an error message, it is possible the necessary environment variables have not been set. See *Running the NerveCenter Server on UNIX on page 38*.

SEE ALSO

ncserver on page 314, *ncstop on page 316*

nccmd

NAME

nccmd

SYNOPSIS

```
nccmd [connect -s server -u userID [-p password] -n port [-f scriptFile | CLIcommand]] | [-?]
```

DESCRIPTION

Runs the NerveCenter command line interface (CLI). You can issue single commands, open a CLI interactive session, or run a CLI script.

OPTIONS

connect

Connects to the specified server. Once you are connected to a server, all subsequent commands are directed to that server.

-s server

Name of the server to which you want to connect. Required.

-u *userID*

User ID under which you want to connect to the server. The default is the user ID specified during the previous connection or by the `nccmd` command line parameter, if any. Required.

-p *password*

Password for the user ID you specified. The default is the password specified during the previous connection or by the `nccmd` command line parameter. `-p` is required for sites that use NerveCenter security.

-n *port*

Number of the port you want to use for client/server communication. The default command-line-interface port is 32506. Required.

-f *scriptfile*

Filename of the script or batch file containing CLI commands.



NOTE

If *scriptfile* is a file name or path name that contains spaces, the name must be enclosed in quotation marks, for example, "C:\Program Files\OpenService\NerveCenter\Bin\Cmd.nc".

To prevent having to connect to the server explicitly each time you want to run your script, you can edit your script so that its first line is a connection command. Once you've performed this step, you can type `nccmd -f scriptfile` from a Windows command prompt or a UNIX shell to connect to the server and execute the commands in your script.

If any command returns an error, `nccmd` quits, displays the error, and returns you to the Windows command prompt or UNIX shell prompt.

CLIcommand

Any one of several command line interface commands listed in the [Command Line Interface Reference on page 331](#).

-?

Provides command-line help for the `nccmd` command.

ncserver

NAME

ncserver

SYNOPSIS

```
ncserver [-fg | -info | -off]
```

DESCRIPTION

Executes the NerveCenter Server application. For information about how to use NerveCenter Server, refer to *Managing the NerveCenter Server on page 53*.

OPTIONS

-fg

Runs NerveCenter in the foreground in a command prompt. Useful when debugging NerveCenter.

-info

On machines installed with NerveCenter Server, displays Server version and copyright information. The Server does not have to be running to use **-info**.

-off

(UNIX only) Disables all alarms when you start the server. (For example, you might want to use **-off** if you create an alarm that causes undesirable results on the server.)

USAGE

Using **ncserver** on Windows runs NerveCenter Server as a process. To run the Server as a Windows service, use **ncstart -p**.

If you use **ncstart -p**, you must also start the NerveCenter SNMP service by using the following command:

```
ncsnmp start
```

You can stop the NerveCenter SNMP service by using the following command:

```
ncsnmp stop
```

If NerveCenter is not running as a UNIX daemon, you can start it manually.

Before you can run any NerveCenter application on UNIX, you must set the necessary environments by executing one of the following shell scripts:

- ◆ *installPath*/userfiles/ncenv.sh
- ◆ *installPath*/userfiles/ncenv.csh
- ◆ *installPath*/userfiles/ncenv.ksh

where *installPath* is typically //opt/OSInc

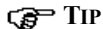
**TIP**

An administrator should add the lines from these files to the login scripts of all users who are going to be using NerveCenter on UNIX.

From the *installPath*/bin directory, where *installPath* is typically /opt/OSInc type the following command:

```
ncserver &
```

SEE ALSO

[ncstart on page 315](#)

ncstart

NAME

ncstart

SYNOPSIS

```
ncstart -h | -p | -s
```

DESCRIPTION

Runs the NerveCenter Server as either a process or a Windows service.

OPTIONS**NOTE**

The following three options are available only on Windows machines.

-h

Displays command line help for ncstart.

-p

Runs the NerveCenter Server as a process.

-s

Runs the NerveCenter Server as a Windows service.

**NOTE**

The following three options are available only on UNIX machines.

-fg

Runs NerveCenter in the foreground in a command prompt. Useful when debugging.

-info

On machines installed with NerveCenter Server, displays Server version and copyright information. The Server does not have to be running to use **-info**.

-off

(UNIX only) Disables all alarms when you start the server. (For example, you might want to use **-off** if you create an alarm that causes undesirable results on the server.)

USAGE

During a NerveCenter installation, the NerveCenter Server is installed as a Windows service. During installation, the choice is given to have the NerveCenter Server service start up automatically.

If the NerveCenter Server is installed as a service but not as an automatic service, you must start it manually each time.

SEE ALSO

[ncserver on page 314](#), [ncstop on page 316](#)

ncstop

NAME

ncstop

SYNOPSIS

ncstop -a | -All | -c | -h | -s

DESCRIPTION

Shuts down one or all NerveCenter applications.

OPTIONS

- a
Shuts down the NerveCenter Administrator application.
- All
Shuts down all NerveCenter currently running. -All is case-sensitive.
- c
Shuts down the NerveCenter Client application
- h
Displays command line help for ncstop.
- s
Shuts down the NerveCenter Server application

SEE ALSO

client on page 295, ncadmin on page 312, ncserver on page 314, ncstart on page 315

ovpa**NAME**

ovpa

SYNOPSIS

```
ovpa [-logLevel Error | Warning | Debug | Trace ]  
      [-traceOutputFile FileName ] [ -traceOutputStdout ]  
      [-traceResync ] [ -traceInform ] [ -traceLoadDb ]  
      [-traceParentComp ] [ -traceMapUpdates ] [ -traceConnects ]  
      [-traceAll ] [ -pc ] [ -writeParentsToFile NcHostName ]  
      [-heartbeat seconds ] [ -ignoreUnmanagedIntf ]  
      [-initNcStatusInOV ] [ -ignoreCapability ]  
      [-noResolveCommunityOnResync ] [-defGlobalCommunity filename]  
      [-preferredAddrOnly]
```

DESCRIPTION

Runs the NerveCenter OpenView Platform Adapter (OVPA).

OpenView (OV) must be running before you can run OVPA. To issue an **ovpa** command (with or without switches) by itself and without also using **ovstart**, you must first remove the OVPA local registration file (ovpa.lrf) from the list of services that are started by OV. For more information, refer to [Integrating with HP OpenView Network Node Manager](#) and [Integrating NerveCenter with IBM NetView for UNIX](#).

OPTIONS



NOTE

All of these command line switches are optional.

`-logLevel Error | Warning | Debug | Trace`

Set logging level, default value is Warning.

`-traceOutputFile FileName`

Set the output of logging messages to be a file with *FileName*.

`-traceOutputStdout`

Set the output of logging messages to be standard output. This option can be used with `-traceOutputFile filename` so that logging messages can be written both to the screen and the output file.

`-traceResync`

Enable logging messages for resync (node source) and resync parents. Logging messages contain node information including parent information OVPA is sending to Nerve Center.

To use this option, the log level must also be set to either debug or trace.

`-traceInform`

Enable logging messages for status informing from NerveCenter to OpenView. It shows status change messages from NerveCenter, whether the status change information is sent to OpenView or is logged into OpenView database.

To use this option, the log level must also be set to either debug or trace.

`-traceLoadDb`

Enable logging messages for loading nodes and interfaces from the OpenView database at initialization stage. It shows each node and each interfaces are loaded.

To use this option, the log level must also be set to either debug or trace.

`-traceParentComp`

Enable logging messages for the details of how the parents are computed for each Nerve Center host.

To use this option, the log level must also be set to either debug or trace.

`-traceMapUpdates`

Enable logging messages for the processing of OpenView events regarding changes. This option displays the significant data that arrived with an OpenView event, how ovpa is processing that event, and whether network topology needs to be updated or not.

To use this option, the log level must also be set to either debug or trace.

`-traceConnects`

Enable logging messages for connections from the NerveCenter server, and from OpenView. It also shows why the port is disconnected.

To use this option, the log level must also be set to either debug or trace.

`-traceAll`

Enable logging messages for resync, inform, loadDb, parentComp, mapUpdates, and connects.

To use this option, the log level must also be set to either debug or trace.

`-pc`

Enable parent computing. Without this option, no parent information is computed for any NerveCenter host, including the requests of resync parents from NerveCenter server, and the command line option `-writeParentsToFile`

`-writeParentsToFile NcHostName`

When `-pc` is turned on, OVPA computes parent-child relationships, writes to the file `NcHostName_PC.dat`, and exits.

`-heartbeat seconds`

The ovpa process and the NerveCenter server process exchange heartbeats. You can configure how often the heartbeat is sent from OVPA using the `-heartbeat` switch. If OVPA doesn't receive a heartbeat from NerveCenter in the specified time then it will close the connection to that server's port. Default heartbeat rate is 300 seconds.

`-ignoreUnmanagedIntf`

If this switch is used OVPA does not send NerveCenter server any unmanaged interfaces within a node. You may want to restrict the interfaces that NerveCenter server must poll to only interfaces that OpenView is currently managing. If you have many subobject scope alarms and nodes, this switch to improves polling performance.

`-initNcStatusInOV`

Synchronizes the status of a NerveCenter icon and its managed nodes.



NOTE

NerveCenter must be configured so that its node data source and inform host are the same. All IP filters must be empty.

`-ignoreCapability`

Determines whether OVPA keeps track of OpenView's capability information, such as IsRouter. For more information, see *Integrating NerveCenter with a Network Management Platform*.

`-ignoreCapability` prevent ovpa from keeping track of capability data. This increases ovpa's speed and decreases its memory usage.

This switch can be turn on when a user wants to force the node to be added to NC server, regardless of capabilities.



NOTE

The `-ignoreCapability` switch disables NerveCenter's ability to filter nodes based on capabilities.

`-noResolveCommunityOnResync`

When this option is turned on, OVPA does not obtain the community strings during a resync or resync parents. You can use this argument when you are sure that the community has not changed since the initial OpenView database import to improve resync performance.

`-defGlobalCommunity filename`

Instead of retrieving community strings through OpenView, you can retrieve them from a file. This option is used to give the filename where user defines default community strings.

`-preferredAddrOnly`

(OpenView only) When you start OVPA with this argument, only the preferred SNMP address is sent from OVPA to NerveCenter on resync.

If you use this argument and the preferred SNMP address for a node is changed manually from OpenView, you must restart OVPA for OVPA to function correctly.

If you use the `-preferredAddrOnly` option, you should start HP Openview netmon with the following command:

```
netmon -k pickSnmpAddrPolls=false
```

These netmon arguments prevent netmon from attempting to test other SNMP addresses.

-info

Display the version of OVPA

-help

Help information for OVPA

NOTES

If you want these settings to take effect every time OVPA is started, edit the file ovpa.lrf to include these switches. On Windows, the file is located in the OpenView/lrf directory. On UNIX, the file is located in the opt/OSInc/nc/OV/lrf directory. For example, to have OVPA compute parenting information only during a resync you would modify ovpa.lrf to read:

```
ovpa:/opt/OSInc/nc/OV/bin/ovpa:  
OVs_YES_START:ovwdb:-pc_noupdate:OVs_WELL_BEHAVED:5:
```

paserver

NAME

paserver

SYNOPSIS

```
paserver [-d] [-g] [-h|-?] [-n ON|OFF] [-nhost] [-nport] [-o] [-p]  
        [-r] [-scm {a|m|r|s}] [-t] [-tcfg] [-thost] [-toneway]  
        [-tport] [-ttype] [-u ON|OFF] [-v]
```

DESCRIPTION

Runs the NerveCenter Universal Platform Adapter for integrating NerveCenter with the network management platforms IBM Tivoli Netcool/OMNIBus and CA Unicenter TNG.

OPTIONS

-d

Runs the Universal Platform Adapter from the command line in debug mode and outputs debug messages to the console. The next time the host machine boots, the Universal Platform Adapter will run as a service or daemon again.

- g
(Windows only) Registers the Universal Platform Adapter as an Event Source.
- h | -?
Displays command line help for the Universal Platform Adapter switches.
- n
Enables or disables NerveCenter integration with IBM Tivoli Netcool/OMNIBus.
On Windows, when starting paserver from the command line, you must specify either **-d** or **-scm option** in combination with either **-n ON** or **-u ON**.
- nhost
Defines the machine on which the Netcool probe is located. The default is localhost.
- nport
Defines the port the NerveCenter platform adapter uses to communicate with IBM Tivoli Netcool/OMNIBus. The default is 32510.
- o
(Windows only) Records values into Registry. Any options (other than -scm) become a part of the standard configuration.
To use this switch, you should first stop the Universal Platform Adapter. You must restart the Universal Platform Adapter.
- p
Defines the platform adapter's listening port. The default is 32509.

**NOTE**

This number must match the one in NerveCenter Administrator.

- r
(Windows only) Shortened version of -scm r. Removes the Universal Platform Adapter as a service. It also removes Registry entries created at install time.
- scm a|m|r|s
(Windows only) Changes settings in the service control manager.
- a
(Windows only) Installs the Universal Platform Adapter as a service, marking it as autostart. The service will start following this command.

- m**
(Windows only) Installs the Universal Platform Adapter as a service or daemon, marking it as start on demand. The service will not start following this command.
- r**
(Windows only) Removes the Universal Platform Adapter as a service. If it the service is running, it will be stopped.
- s**
(Windows only) Starts the Universal Platform Adapter as a service. This may be combined with **a** or **m**.
- t**
Enables or disables NerveCenter integration with IBM Tivoli TME.
- tcfg**
Defines the full qualified path/filename for the Event Adapter configuration file. The default is /opt/OSInc/userfiles/nctec.cfg
- thost**
Defines the machine on which the Tivoli Event Server is located. The default is localhost.
- toneway**
Defines the best-effort delivery method to the IBM Tivoli TME agent. The default is 0.
- tport**
Defines the port the NerveCenter platform adapter uses to communicate with Tivoli Event Server. The default is 32510.
- ttype**
Defines the type of connection to be established with the Tivoli Event Server:
- ◆ 0 Connectionless delivery to agent.
 - ◆ 1 Connection-oriented (secure) delivery to agent.
 - ◆ 2 Default type of connection.
- The default is 0.
- u**
Enables or disables NerveCenter integration with CA Unicenter TNG.

On Windows, when starting paserver from the command line, you must specify either **-d** or **-scm option** in combination with either **-n ON** or **-u ON**.

-v

Views current Universal Platform Adapter settings.

NOTES

If you want these settings to take effect every time the Universal Platform Adapter is started, edit the file `pastart` to include these switches. `pastart` resides in NerveCenter `\bin` directory.

On Windows, when starting paserver from the command line, you must specify either **-d** or **-scm option** in combination with either **-n ON** or **-u ON**.

semsopca



NOTE

The SEMSOPCA binary is provided for historical purposes only. It is deprecated and not supported.

NAME

`semsopca`

SYNOPSIS

```
semsopca [-agent] [-v1]
```

DESCRIPTION

A OpenService-supplied interface that enables NerveCenter to send and receive Hewlett Packard's OpenView IT/Operations (ITO) messages. NerveCenter setup installs the IT/O Platform Adapter when OVPA platform integration is selected.

OPTIONS

-agent

Connects to the OpC agent interface. By default, `semsopca` connects to the OpC server interface.

-v1

Pipes `semsopca` messages to the UNIX shell console.

USAGE

The `-v1` switch is equivalent to setting the UNIX environment variable `NL_OPC_VERBOSE = 1`.

serializedb

NAME

serializedb

SYNOPSIS

```
serializedb
-f fullyQualifiedFilename.asc
-o {dbtofile|filetodb}
{-r} | {-c "DSN=dataSourceName;UID=userID;PWD=password"} | {-d
fullyQualifiedFilename.ncdb}
```

DESCRIPTION

Exports or imports the data in your NerveCenter database. You can run SerializeDB from a GUI, the command line, or from a script.

**CAUTION**

Before you import from or export to a database, you must shut down the NerveCenter Server. If you don't shut down the NerveCenter Server, you could lose data.

If you are importing from or exporting to a UNIX flat file database, all of the files that make up the database (NerveCenter.ncdb and NerveCenter.node) must be in the same directory.

options

`-f` *fullyQualifiedFilename.asc*

Name of the backup file you want SerializeDB to export to or import from. If you do not specify a path, SerializeDB creates (or searches) for the file in your current working directory.

`-o` *dbtofile* or *filetodb*

Specifies whether you are using SerializeDB to export or to import NerveCenter data.

`-r`

(Windows only) Instructs SerializedDB to get the data source name, user ID, and password from the NerveCenter registry. You can use `-r` with a Microsoft SQL Server database or a Microsoft Access database.

`-c "DSN=dataSourceName;UID=userID;PWD=password"`

(Windows only) Specifies that you are exporting from a Microsoft SQL Server database. Replace *dataSourceName* with the existing data source name, *userID* with the appropriate SQL Server user ID, and *password* with the corresponding password.

`-d fullyQualifiedFilename.ncdb`

(UNIX only) Specifies the fully qualified database pathname (for example, `/opt/OSInc/db/NerveCenter.ncdb`). If you don't specify a path, NerveCenter uses the current working directory.

USAGE



CAUTION

On UNIX, SerializedDB requires an Xdisplay even when running in command line mode. Therefore, do not run SerializedDB remotely or on a headless server via TTY.

Unless you use fully qualified pathnames, SerializedDB reads and writes to the current working directory.

When running SerializedDB from the command line, you can only export to a serialized file (.asc file).

Use the timestamp and the size of the file as an indicator of success. For example, if the timestamp is old or the file size is 0K, you need to investigate further. Check the UNIX system log or the Windows Event Log for error messages.

trapgen

NAME

trapgen

SYNOPSIS

```
trapgen {-v1 | -v2c | -v2cinform | -v3inform} [-p port] [-c community]
        [-w [-t timeout] [-r retries] ] destinationAddress
        enterprise {agentAddress | trapOID}
        {genericTrapNumber | specificTrapNumber} timeStamp
        NoAuth|MD5|SHA NoPriv|DES username [variable type value...]
```

DESCRIPTION

TrapGen is a standalone utility that allows you to send an SNMP trap or inform to a particular device. From a command line or shell prompt, you can set the generic and specific trap numbers, provide the sender and recipient IP addresses, include an enterprise identifier, and specify the variable bindings.

Generating a trap is useful for testing trap masks and behavior models. When you send an SNMP trap to a NerveCenter Server, any trap mask configured to detect the specified trap values fires its trigger. If your trap mask and alarm are working properly, you see the alarm listed in your console.

OPTIONS

`-v1`

Sends a SNMP v1 trap. This is the default

`-v2c`

Sends a SNMP v2c trap.

`-v2cinform`

Sends a SNMP v2c inform.

`-v3inform`

Sends a SNMP v3 inform.

`-p port`

Port number to which the trap is being sent. The default is 162.

`-c community`

The community name for the agent sending the trap. The default is “public”.

`-w`

Use with `-v2cinform` and `-v3inform` to wait for a response back from the machine to which the inform is being sent.

`-t timeout`

The time in hundredths of a second for which Trapgen waits for a response from an inform. The default is 300 (3 seconds).

`-r retries`

The number of times Trapgen will attempt to re-send an inform if the inform does not respond. The default is 0.

destinationAddress

Destination address for the trap. *destinationAddress* can be an IP address or a node's name.

enterprise

(v1 only) SNMP enterprise-specific trap number in dot notation (such as 1.3.6.1.4.1.9) that identifies the agent sending the trap. You can specify a null value ("" for *enterprise*. The null value equates to 1.3.6.1.4.1.78.

agentAddress

(v1 only) Agent sending the trap. *destinationAddress* can be an IP address or a node's name. You can specify a null value ("" for *agentAddress*.

trapOID

(v2c, v2cinform, and v3inform only) A unique object identifier for the trap itself.

genericTrapNumber

(v1 only) One of the SNMP generic trap numbers (0-6).

- ◆ 0—coldStart
- ◆ 1—warmStart
- ◆ 2—linkDown
- ◆ 3—linkUp
- ◆ 4—authenticationFailure
- ◆ 5—egpNeighborLoss
- ◆ 6—enterpriseSpecific

specificTrapNumber

(v1 only) A particular enterprise-specific trap number. If not used, specify zero.

timeStamp

Time elapsed between the last (re)initialization of the entity and the generation of the trap in hundredths of seconds. Taken from the MIB-II object, **system.sysUpTime**. You can specify a null value ("" for *timeStamp*. The null value equates to 1.

NoAuth | MD5 | SHA

(v3inform only) The authentication protocol. If you are sending a v3inform, you must supply an authentication protocol.

NoPriv | DES

(v3inform only) The privacy protocol. If you are sending a v3inform, you must supply a privacy protocol.

username

(v3inform only) Name of a user configured on the remote agent. The default is ncuser.

variable

Name of *variable*. *variable* must be a valid OID in dot notation. A string is not acceptable. For example, use 1.3.6.1.2.1.1.1.0 instead of sysDescr.0.

type

Type for *variable*. *type* can be one of the following: integer, integer32, uinteger32, octetstring, objectidentifier, ipaddress, counter, counter32, counter64, gauge, gauge32, timeticks.

value

Value of *variable*. Enclosing strings with quotes is optional.

EXAMPLES

Example 1: In the following example, Trapgen sends an generic SNMP v1 authentication failure trap from the NerveCenter Server Blueridge to itself:

```
trapgen blueridge "" blueridge 4 0 ""
```

enterprise and *timeStamp* are nulls ("") and *specificTrapNumber* is 0 since a trapgen is sending a generic trap.

Example2: In the following example, Trapgen sends to Blueridge a v2c trap identified with a unique OID (1.3.6.1.2.1.1.1), from an agent (1.3.6.1.4.1.9.1.3) using a null timestamp:

```
trapgen -v2c blueridge 1.3.6.1.4.1.9.1.3 1.3.6.1.2.1.1.1 ""
```

Example 3: In this example, Trapgen sends to the node 10.52.174.139 a specific trap number (110000) from the node poe. The trap contains two varbinds with a values of type timeticks and octetstring, respectively.

```
trapgen 10.52.174.139 1.3.6.1.4.1.9.1.3 poe 6 110000 900
1.3.6.1.2.1.1.3 timeticks 9875632 1.3.6.1.2.1.1.1 octetstring "Cisco
trouter"
```

Example 4: In this example, Trapgen sends an SNMPv3 Inform to a remote NCServer at 10.69.89.51. The remote NCServer is setup with the default SNMPv3 user (ncuser). A null time stamp is used.

```
trapgen -v3inform -w 10.69.89.51 1.3.6.1.4.1.78 1.3.6.1.4.1.78.3.5 ""
NoAuth NoPriv ncuser
```

Traprcv

NAME

trapgen

DESCRIPTION

The traprcv command displays the SNMP Trap messages received by the NerveCenter Trap service. This utility can be useful when debugging behavior models. When you run the traprcv command from a command line or shell prompt, any trap you receive is shown on the screen.

Traprcv can receive the following traps and informs:

- ◆ SNMPv1 Traps
- ◆ SNMPv2c Traps
- ◆ SNMPv2c Informs
- ◆ SNMPv3 Traps
- ◆ SNMPv3 Informs

Command Line Interface Reference

You can use NerveCenter commands to control NerveCenter servers, nodes, alarms, polls, and masks from the command line interface from a scriptfile, single command, or interactive session.

The commands are generally made up of an action and an object on which you perform the action. For example, the command **list mask** is made up of the list action, which is performed on the mask object.

This reference consists of the following sections:

- ◆ *Server commands on page 331*
- ◆ *Object commands on page 334*
- ◆ *General commands on page 336*
- ◆ *Notes for CLI commands on page 337*
- ◆ *CLI command examples on page 337*

Server commands

Use these commands to list, select, disconnect from, or display information about connected NerveCenter Servers in your CLI session. These commands are listed in the order that they appear in the syntax diagram.

```
serverCommand [-serverSwitch [parameter]] [-serverSwitch [parameter]]...|-?
```

serverCommand

One of the several server-related keywords and their switch/parameter pairs described below. *serverCommand* also includes the connect command and its switch/parameter pairs described in *OPTIONS* of *nccmd* on page 312.

NerveCenter directs server commands to the active server if no server is specified. The active server is the last server connected to or selected using the select server command.

TABLE C-2. Server Commands

serverCommand	Description	Options
clear trigger -t <i>triggerName</i> [-i <i>alarmInstanceID</i>]	Cancels any pending triggers of a specified name that have been queued by its own alarm instance. If no alarm instance is supplied, then NerveCenter cancels the specified trigger for all alarms in which the trigger is pending.	-t <i>triggerName</i> Name of the trigger to be cleared. -i <i>alarmInstanceID</i> (Optional) <i>alarmInstanceID</i> is a numeric value which indicates the instance of the alarm for which NerveCenter is clearing the specified trigger.
disconnect	Disconnects from the active server.	
fire trigger -t <i>triggerName</i> -n <i>nodeName</i> \$ANY -o <i>subobjectName</i> \$ANY [-d <i>delay</i>]	Fires the specified trigger. If no delay is supplied, then NerveCenter fires the trigger immediately.	-t <i>triggerName</i> Name of the trigger to be cleared. -n <i>nodeName</i> \$ANY Name of the node on which to fire the trigger or any node (\$ANY). -o <i>subobjectName</i> \$ANY The name of the subobject on which the trigger is fired or any subobject (\$ANY). -d <i>delay</i> (Optional) <i>delay</i> is a numeric value (in seconds) for NerveCenter to wait before it fires the specified trigger.
list	Lists connected servers.	
select -s <i>serverName</i>	Makes <i>serverName</i> the active server. <i>serverName</i> is one of the connected NerveCenter Servers.	

TABLE C-2. Server Commands (Continued)

serverCommand	Description	Options
<code>set server {-t timeoutInterval} {-w width} -?</code>	Allows you to configure how the server commands respond.	<p><code>-t timeoutInterval</code> <i>timeoutInterval</i> is the number of seconds that the CLI waits for an acknowledgement from the NerveCenter Server that a CLI request was received. The default value for timeouts is five seconds (UNIX) and one second (Windows). <code>-t timeoutInterval</code> is commonly used in situations where a Server is busy or the connection is slow. Should a timeout occur, connection to the Server is still maintained, but the CLI displays the message: Error. No data was received within allowed time.</p> <p><code>-w width</code> <i>width</i> is the character width (1-50) of columns for tabular output that the NerveCenter CLI list command displays. The default for <i>width</i> is 12 characters.</p> <p><code>-?</code> displays help for the set server commands.</p>

-switch parameter

One of several switch/parameter pairs described below. Parameter switches can be preceded by either a hyphen (-) or a backslash (\).

```
show server -serverSwitch
```

Displays information about the active server.

TABLE C-3. Server Switches

<code>-serverSwitch</code>	Description:
<code>-a</code>	Display information about the NerveCenter administrators connected to the active server.
<code>-c</code>	Display information about the NerveCenter clients connected to the active server.
<code>-d</code>	Display information about the NerveCenter database.
<code>-h</code>	Display information about the Inform host.

TABLE C-3. Server Switches (Continued)

<i>-serverSwitch</i>	Description:
-i	Display information about the active server.
-l	Display information about the NerveCenter license key.
-m	Display information about the map host.
-s	Make the specified <i>serverName</i> the active server. Used only with the <i>serverCommand select</i> .
-?	Display help information about the specified <i>serverCommand</i> .

Object commands

Use these commands to delete, list, or set alarms, trap masks, nodes, and polls. These commands are listed in the order that they appear in the syntax diagram.

```
{delete | list object {-switch parameter} | -? } |
{set object {-switch parameter -w targetObject} | -? }
```

delete

Deletes the specified *object*. One switch/parameter pair is required.

list

Lists the specified alarm, mask, node, or poll when specified with a switch/parameter pair. When used without a switch/parameter pair, displays a list of the connected and active servers (if any).

object

Specifies the type of NerveCenter object that you are deleting, listing, or setting attributes for. *object* can be: alarm, mask, node, or poll.

-switch parameter

One of several switch/parameter pairs described below. Parameter switches can be preceded by either a hyphen (-) or a backslash (\).

*-a name | **

Identifies a specific NerveCenter alarm or poll (*name*) or all (*) alarms or polls. *name* is case-sensitive. *-a* does not apply to trap masks. See *-m*, *-n*, and *-p*.

-a authenticationProtocol

Identifies NerveCenter nodes by their authentication protocols. Valid *authenticationProtocol* values are: MD5 (Message Digest algorithm) and SHA (Secure Hash Algorithm). The default protocol is MD5. For privacy, the CBC-DES protocol will be used, since this is the default provided by Envoy.

`-e on | off`

Identifies NerveCenter objects by their state: enabled (on) or disabled (off).

`-g propertyGroup`

Identifies NerveCenter nodes by their property group.

`-l securityLevel`

Identifies NerveCenter nodes by their SNMP v3 security level. Valid *securityLevel* values are: NoAuthNoPriv (no authentication protocol, no privacy password), AuthNoPriv (authentication protocol, no privacy password), and AuthPriv (authentication protocol, privacy password).

`-m name | *`

Identifies a specific NerveCenter trap mask (*name*) or all (*) trap masks. *name* is case-sensitive. `-m` only applies to trap masks. See `-a`, `-n`, and `-p`.

`-m yes | no`

Specifies NerveCenter managed nodes (yes) or unmanaged nodes (no).

`-n name | *`

Identifies a specific NerveCenter node (*name*) or all (*) nodes. *name* is case-sensitive. To display extended SNMP v3 attributes (security level, authentication protocol, and error status), use `-x v3`. See `-a`, `-m`, and `-p`.

`-p name | *`

Identifies a specific NerveCenter poll (*name*) or all (*) polls. *name* is case-sensitive. See `-a`, `-m`, and `-n`.

`-s enterprise | node | subobject | instance`

Identifies NerveCenter alarms by their scope.

`-s yes | no`

Identifies NerveCenter nodes their state: suppressed (yes) or unsuppressed (no).

`-r propertyName`

Identifies NerveCenter alarms or polls by their property. *propertyName* is case-sensitive.

`-r errorStatus`

Identifies NerveCenter nodes by their error statuses. Valid *errorStatus* values are: AuthKeyFail, AuthPrivKeyFail, V3InitFail, ClassifyFail, TimeSyncFail

`-v SNMPVersion`

Identifies NerveCenter masks, nodes, or polls by the version of the SNMP agent. Valid *SNMPVersion* values are: 1, 2, or 3.

`-w targetObject`

Flag indicating that target object follows for the set command.

The arguments preceding the `-w` switch determine which attributes of an object(s) are set and what they are set to. Those that follow `-w` determine which object(s) are modified. For example, the sequence `-r property1 -w -r property2` would change the property of all objects with *property2* to *property1*.

targetObject

Switch/parameter pair that identifies the NerveCenter objects whose attributes are being set.

`-x v3`

Displays extended attributes of all SNMP v3 nodes. These attributes (security level, authentication protocol, and error status) are not displayed by the **list node -n** command.

`-?`

Display help information about the delete/list/set *object* command.

`set`

Sets attributes for the specified object. One switch/parameter pair and `-w targetObject` is required.

General commands

Use these commands to get command line help, quit the NerveCenter CLI, or to resync with the network management platform. These commands are listed in the order that they appear in the syntax diagram.

```
-? | quit | reset alarm_instance -i instanceNumber [-s stateName] | resync
-?
```

Displays help. If used without an action keyword or *object*, displays general information about help. If used with an action alone, gives general information about the command,

including the command's syntax and the objects to which it can be applied. If used with an action and *object*, gives detailed information about the command's syntax.

`quit`

Ends the CLI session and automatically disconnects from each connected NerveCenter Server.

`reset alarm_instance`

Transitions the specified alarm to the ground state.

`-i instanceNumber [-s stateName]`

Identifies the alarm to be reset to ground by a valid alarm instance number (required) and the state of the alarm (optional).

`resync`

Updates the NerveCenter node list with information from the network management platform. NerveCenter automatically executes a resync at startup and when you reconnect to the platform after the connection was broken.

Notes for CLI commands

If you leave out any mandatory parameters, `nccmd` returns an error. In general, `nccmd` also returns an error if it encounters any syntax errors (for example, unknown or incorrectly specified parameters) and does not issue the command to the connected server. Specific error messages are returned by `nccmd` if the server encounters errors.

CLI command examples

The following command starts a CLI interactive session, connecting to the Blueridge server, with the user ID GRakauskas, and using port 32506:

```
nccmd connect -s blueridge -u GRakauskas -n 32506
```

This command sets the property to `mynodes` for all alarms that are enabled:

```
set alarm -r mynodes -w -e on
```

The command that follows assigns all nodes belonging to the `troublemaker` property group to the `criticaldevices` property group:

```
set node -g criticaldevices -w -g troublemaker
```

In this example, all alarms set to enterprise scope are displayed:

C

Controlling NerveCenter from the Command Line

```
list alarm -s enterprise
```

- Action Router** Performs standard NerveCenter alarm actions in response to detected network conditions and based on additional conditions that you specify. In NerveCenter Client, you first define a set of conditions along with the actions to be completed. Then, you can assign the Action Router action to an alarm transition. When the transition occurs, NerveCenter evaluates all existing conditions to determine whether any have been met and, therefore, whether one or more conditional actions should be performed. All alarms that are sent to the Action Router are evaluated against all the current rules.
- See also *alarm action*.
- Action Router rule** An Action Router rule is composed of a conditional statement and one or more actions. The conditional statement can contain one or more conditions logically joined together.
- Administrator rights** Users with administrator logon rights can customize NerveCenter and save changes to the NerveCenter database. In the NerveCenter Client, administrator rights are required to create or modify the objects used in behavior models. Those with administrator rights belong to the NerveCenter Admins group on Windows NT or to ncadmins on UNIX. They can also log in as administrator on Windows NT or root on UNIX.
- See also *user rights*.
- alarm** A NerveCenter object that detects a trigger generated by a poll, trap mask, OpC mask, Perl subroutine, or another alarm. The alarm is a finite state machine that transitions from one state to the next and performs any actions assigned to a transition. Each transition is triggered by its own set of network data, which is defined in the associated trigger generator. When an alarm detects its first trigger, the alarm transitions to the next state, where it remains until another trigger is received—either from the same or another trigger generator. The sequence of transitions enables NerveCenter to monitor persistent, simultaneous, or sequential events that, taken together, indicate a critical or important condition.

alarm action A NerveCenter automated response that helps you manage network activity and stay informed about network conditions. You can assign one or more actions to any transition in an alarm state diagram.

Actions fall into four main categories: notification, logging, triggering other alarms, and correcting network conditions. Examples include sending e-mail, issuing a page, logging data, sending an SNMP trap, executing a command, and sending an Inform message to a network management platform. In addition, NerveCenter actions can be performed conditionally based on criteria that you specify using the Action Router.

alarm circular transition A circular transition is one in which the From State and To State are the same for a transition in an alarm state diagram. When a trigger containing the polled data arrives at this transition, the transition occurs and returns the alarm to the same state. The effect is that the alarm continues looping with each instance of the trigger. This type of transition usually includes an alarm counter action that tracks the number of occurrences and fires a trigger when the number reaches a certain value.

alarm instance A single instance of a detected network event. Each instance is one active occurrence of an alarm definition that tracks a current network or system condition through its own copy of the alarm's state diagram. For example, one alarm might have five distinct alarm instances, each tracking the same condition on a different node.

See also *alarm scope*.

alarm instance ID The unique identifier for an alarm instance managed by a NerveCenter Server. The instance ID is listed in the Alarm History window for an alarm instance.

NerveCenter includes a variable `$AlarmInstanceID` that you can use in Perl subroutines, command actions, and log actions to specify the instance ID associated with an alarm.

alarm scope A setting that determines whether an alarm instance monitors a subobject (for example, a port), several MIB objects on a subobject, a node, or an entire enterprise. Scope is assigned in an alarm's definition window.

If an alarm is using node scope, each alarm instance tracks the alarm's states for a single, distinct node. If an alarm is using subobject scope, each instance tracks the alarm's states for a MIB base object on a node, for example, an interface on a router. Instance scope alarms track instances for every interface or port that fits the polled condition regardless of the base object. Enterprise scope alarms track an event for the enterprise as a whole.

alarm severity	An indication of the urgency of a detected event. When creating an alarm, you assign each state a severity level, which is defined by a name and unique color. NerveCenter ships with severity options ranging from normal to critical for a fault condition, and from very low to saturated for a traffic condition. If your network management platform has event severities, you can map NerveCenter's severities to match those on your platform.
alarm state	Corresponds to a network condition that an alarm is monitoring. To monitor certain network conditions, or states, you must specify these states in the alarm's state diagram. Each state listens for certain triggers. Once the correct trigger is fired, the alarm transitions to the corresponding state.
alarm state diagram	Specifies which detected conditions are correlated, in what order, and which responses (if any) are assigned to each stage. For each alarm that you create, you design a state diagram to specify the states you want to monitor. The state diagram can detect persistent, simultaneous, or sequential events that, taken together, indicate a critical or important network condition. Incoming triggers transition the alarm from one state to another.
alarm summary views	<p>NerveCenter Client provides two views for monitoring network activity. Both windows can be opened from the Admin menu or the toolbar:</p> <p>Alarm Summary - In the Alarm Summary window, you monitor alarm instances for the connected server. If you are connected to more than one server, you can change the active server and view the Alarm Summary window for the new server. To do this, select the server you want to view from the Active Server drop-down listbox on the NerveCenter toolbar.</p> <p>Aggregate Alarm Summary - In the Aggregate Alarm Summary window, you can monitor alarm instances collectively for all servers to which you are connected.</p>
alarm transition	A change from one alarm state to another, prompted by a <i>trigger</i> . When an alarm transitions from its ground state, the transition creates an alarm instance. Further triggers affect the current alarm instance, each generating a transition in the alarm. During a transition, NerveCenter carries out any alarm actions that are assigned to the transition.
ASN.1 file	<p>MIB base objects are defined using Abstract Syntax Notation One (ASN.1), a language that's understood by network management protocols. The ASN.1 language is described in the ISO documents ISO.8824 and ISO.8825.</p> <p>See also <i>Management information base (MIB)</i>.</p>
attribute	NerveCenter terminology includes two meanings for the word attribute:

A MIB object that contains an actual value. For example, `sysContact`, `ifInOctets`, and `ipInDiscards` are all attributes in the industry-standard MIB-II because they contain strings, numbers, or other values. The value associated with an attribute can be static (for example, the speed of the interface) or dynamic (for example, an entry in a routing table).

A value that you assign to a NerveCenter object. For example, if you assign a property to a poll, that property is an attribute of the poll. NerveCenter's Set Attribute alarm action allows you to change certain node, poll, trap mask, or alarm attributes when a specified network condition is detected.

authentication In SNMP v3 communication, the process of confirming the parties (i.e. entities) that communicate with each other as well as the timeliness of the messages received at an SNMP v3 entity.

authentication key The seed used to generate a message digest, as specified in the authentication protocols, to authenticate SNMP v3 messages. Both sender and receiver generate the digest, and the receiver matches the generated digest against the digest accompanying the message received to authenticate the message.

authentication protocol Protocol used with SNMP v3 communication that allows you to verify the sender and timestamp of a message. Two authentication protocols are currently defined: HMAC-MD5-96, which is based on MD5, and HMAC-SHA-96, which is based on SHA-1 cryptographic algorithms. NerveCenter supports both protocols.

AuthNoPriv Security level that requires message authentication services to be used while communicating with an SNMP v3 entity.

AuthPriv Security level that requires both the message authentication and message encryption services to be used while communicating with an SNMP v3 entity.

base object See *MIB base object*.

behavior model The group of all alarm, trigger generator, and property group definitions required to detect and handle a particular network or system behavior. A typical behavior model consists of an alarm with all its supporting trigger generators, though behavior models can have multiple alarms. Any NerveCenter object can be associated with one or more behavior models.

You can customize the behavior models that ship with NerveCenter as well as create new behavior models.

boots See engine boots.

CBC-DES	A privacy protocol as specified in SNMP v3 specifications to be used for message encryption in communication between two SNMP v3 entities with AuthPriv security level. This protocol is supported by NerveCenter.
Computer Associates Unicenter TNG	A network management platform that can be configured to receive NerveCenter Inform messages. The Unicenter platform host requires NerveCenter's universal platform adapter to communicate with NerveCenter.
context	Every communication between two SNMP v3 entities takes place on behalf of a <i>user</i> (a uniquely identified entity in the SNMP v3 management domain) in some <i>context</i> (a uniquely identified entity for access control generally configured on conventional SNMP v3 agents/nodes) with any one of three security levels. These three parameters (user, context, and security level) are used together by VACM (View based Access Control Mechanism defined in SNMP v3 specifications) to grant access to any MIB data at the agents/nodes. Context can be thought of as the MIB information available to a particular user who seeks information from an agent using a certain security level. By default, the NerveCenter user is NCUser and the NerveCenter context is NCContext.
correlation expression	A Boolean expression you can use to create alarms.
DBWizard	The utility that enables you to create or convert a NerveCenter database on Windows. Run the Database Wizard, DBWizard.exe, from your Start menu. See also SerializeDB .
DES	A privacy protocol as specified in SNMP v3 specifications to be used for message encryption in communication between two SNMP v3 entities with AuthPriv security level. This protocol is supported by NerveCenter. See also CBC-DES.
digest	The hashing code generated for message authentication using authentication key. This digest is appended to the message being sent out by a sending SNMP v3 entity. The receiving SNMP v3 entity separate out this digest from the message, generate the digest again from the message using the locally available authentication key and then compares the two digests for message authentication.
discovery	The process of discovering nodes and adding them to the NerveCenter database. When you enable discovery, if the NerveCenter database does not already contain a node matching the source of an SNMP trap or NerveCenter Inform, it adds that node to the database. You can also customize NerveCenter's Discovery behavior model, which uses a TCI/IP sweep program (ipsweep.exe) to populate your node list. Alternatively, the NerveCenter node list can be populated from your network management platform.

D

Glossary

Downstream alarm suppression	A NerveCenter behavior model that uses parent-child topology information to determine the status of nodes and suppress polling on nodes that are down.
engine boots	Number of times an SNMP v3 engine has been started or re-initialized (i.e., booted) since its engine ID was last configured.
engine ID	An <code>SNMPEngineID</code> value with a length of 12 octets that uniquely identifies an SNMP v3 engine within the SNMP v3 management domain. There is one SNMP engine ID for every instance of a NerveCenter Server.
engine information	An SNMP v3 agent's engine ID, boots, and time ticks.
engine time ticks	As defined in SNMP v3 specifications, number of seconds elapsed since the last engine boot. When this counter reaches its maximum limit, it is reset to 0 and the engine boots value is incremented by 1.
enterprise scope	A setting for an alarm definition that determines that there will be at most one alarm instance monitoring the entire enterprise. See also <i>alarm scope</i> .
escape character	If you enter an expression that contains a period, NerveCenter interprets the string as if it were a <code>BaseObject.Attribute</code> . In order to use a period in any other context, you must use an escape character (<code>\</code>) with the period. This applies to filenames, IP addresses, or any other string containing a literal "." character. For example, if your script refers to a fully qualified host name, you might enter something like the following: <pre>if (\$nodeName ne "myhost\mydomain\.com" { FireTrigger (mytrigger); }</pre>
event	A detected network or system condition. An event can be forwarded to one or more NerveCenters and network management platforms.
generic trap number	Indicates the nature of an SNMP trap detected by a NerveCenter trap mask. There are seven different types of traps, numbered 0 through 6. The first six (0-5) are industry-standard traps and are described in any standard SNMP text. NerveCenter also provides an option for selecting all six traps. Trap number 6 is reserved for enterprise-specific traps and NerveCenter Inform actions. See also <i>specific trap number</i> .
Hewlett Packard OpenView IT/Operations	A part of the OpenView network management platform that provides network and system management. NerveCenter integrates with IT/Operations by sending OpC Informs and receiving IT/Operations messages, which are detected by OpC

	asks. IT/Operations requires the SEMSOPCA adapter on its host machine. SEMSOPCA is installed when OVPA platform integration is selected during installation.
Hewlett Packard OpenView Network Node Manager	A part of the OpenView network management platform that provides network discovery, a map, threshold detection, a MIB browser, an event browser, and other functions. NerveCenter integrates with Network Node Manager by retrieving nodes from its OpenView database, sending color changes to the node symbols on the map, and sending events to the event browser. The Network Node Manager host requires NerveCenter's OVPA adapter to communicate with NerveCenter.
HMAC-MD5-96	See MD5 .
HMAC-SHA-96	See SHA .
IBM Tivoli Systems TME 10 Enterprise Console	A network management platform that can be configured to receive NerveCenter Inform messages. The Enterprise Console platform host requires NerveCenter's universal platform adapter to communicate with NerveCenter.
IBM Tivoli Systems TME 10 NetView	A network management platform that provides network discovery, a map, threshold detection, a MIB browser, an event browser, and other functions. NerveCenter integrates with NetView by retrieving nodes from its database, sending color changes to the node symbols on the map, and sending events to the event browser. The NetView host requires NerveCenter's OVPA adapter to communicate with NerveCenter.
inform message	<p>A message indicating a specified network condition. You can configure alarms to send a NerveCenter Inform when a particular network event is detected. NerveCenter can send the Inform data to one or more NerveCenters and network management platforms.</p> <p>In NerveCenter Administrator, you specify the Inform recipients in the Inform tab. You also determine which types of events are forwarded (for example, those above a specified severity level). This allows you to manage which platforms handle which events. You can use separate criteria for each platform that is to receive events. You can also coordinate alarms from multiple NerveCenters so that one central NerveCenter determines which events should be forwarded to the platform.</p>
instance	<p>The identity of a particular MIB base object when there are multiples of that base object on a node. For example, if a managed node has four ports, it has four instances of the ifEntry base object, numbered one through four.</p> <p>In NerveCenter, a base object and its instance is called a subobject.</p>

- instance scope** A setting for an alarm definition that lets you monitor one or more base objects in an alarm instance. Instance scope is similar to Subobject scope but has the following difference: Instance scope lets you monitor any instance for different base objects.
- See also *alarm scope*.
- IP address** The 32-bit host address defined by the Internet Protocol in STD 5, RFC 791. It is usually represented in dotted decimal notation, for example, 192.164.10.0.
- logon rights** NerveCenter Client users are grouped into two categories, depending on their logon rights:
- ◆ Those with administrator rights can customize and create NerveCenter behavior models and save all changes to the NerveCenter database. These users belong to the NerveCenter Admins group (Windows) or nadmins (UNIX). They can also log in as an administrator on Windows or root on UNIX.
 - ◆ Those with user rights belong to the NerveCenter Users (Windows) or ncusers (UNIX) group. They perform such tasks as monitoring NerveCenter alarms, resetting alarms, and generating reports. They cannot modify the NerveCenter database, for example, by making changes to nodes, property groups, polls, masks, or alarms.
- managed node** A node that can be targeted by NerveCenter polls. Only managed nodes are polled. SNMP traps, however, are received from nodes regardless of their managed state.
- See also *node*.
- Management information base (MIB)** A defined collection of device information that's governed by SNMP. An agent's MIB contains the configuration and status values for the particular type of device. A specific type or class of management information is called a MIB base object.
- MIB-II defines the common set of objects for network management of TCP/IP-based intranets. Other enterprise-specific MIBs can be defined to support specific pieces of hardware.
- See also *Simple Network Management Protocol (SNMP)*.
- map** The graphic representation of your network and its devices that a network management platform provides.
- mask** See *trap mask*.

MD5	Message authentication/ hashing algorithm as defined in HMAC-MD5-96 specifications, intended for secure message exchanges between any two entities communicating with each other. The algorithm takes a message of arbitrary length and produces a 128-bit message digest. This is one of the two algorithms suggested in SNMP v3 specifications for message authentication. This protocol is supported by NerveCenter.
MIB	See <i>Management information base (MIB)</i> .
MIB base object	<p>An object that is managed by a network manager. Base objects contain attributes that have values. In MIB-II, for example, system, ifEntry, icmp, and ipAddrEntry are all base objects. System contains attributes such as sysDescr and sysUpTime that have associated values.</p> <p>Some base objects, such as system, are simply the MIB group name and contain a single set of attributes. These are zero-instance base objects because they have no separate instances. Other base objects represent one instance out of two or more. IfEntry, for example, is one interface on a device that may contain several interfaces. Connecting the base object name and instance number with a period, as in ifEntry.2, fully qualifies the base object instance that is being referenced.</p>
IBM Tivoli Netcool/ OMNibus	A network management platform that can be configured to receive NerveCenter Inform messages. The Netcool platform host requires NerveCenter's universal platform adapter to communicate with NerveCenter.
multitier behavior model	<p>A behavior model that contains two or more alarm definitions. A transition in one alarm instance fires triggers to feed other transitions in other alarm instances. This is useful when you want to correlate conditions that first need to be correlated themselves, or when you want to correlate conditions for a node, but need information from another node to determine the final outcome.</p> <p>This type of behavior model can exploit NerveCenter's alarm scope capability. For example, if you want to be notified when a device has high traffic on its ports, you can design a subobject scope alarm to detect high traffic for a single port. This alarm sends a trigger to a second alarm each time heavy traffic is detected on the port. The second alarm uses node scope and processes at most one trigger for the port. The second alarm notifies you once when the node's port is busy.</p>
NCContext	Every communication between two SNMP v3 entities takes place on behalf of a <i>user</i> (a uniquely identified entity in the SNMP v3 management domain) in some <i>context</i> (a uniquely identified entity for access control generally configured on conventional SNMP v3 agents/nodes). Before NerveCenter can poll SNMP v3 agents, the agents must be configured to support a NerveCenter user and

	NerveCenter context. By default, the user is NCUser and the context is NCContext, though you can change both names in NerveCenter Administrator.
NCUser	Every communication between two SNMP v3 entities takes place on behalf of a <i>user</i> (a uniquely identified entity in the SNMP v3 management domain) in some <i>context</i> (a uniquely identified entity for access control generally configured on conventional SNMP v3 agents/nodes). Before NerveCenter can poll SNMP v3 agents, the agents must be configured to support a NerveCenter user and NerveCenter context. By default, the user is NCUser and the context is NCContext, though you can change both names in NerveCenter Administrator.
NerveCenter Administrator	The NerveCenter software module that enables you to customize and manage NerveCenter operations. Run the NerveCenter Administrator program, <code>ncadmin.exe</code> , from your Start menu program group (Windows NT) or from the <code>NerveCenter_installation/bin</code> directory.
NerveCenter administrator	A system or network administrator who is responsible for configuring and maintaining NerveCenter operations and, optionally, installing NerveCenter.
NerveCenter Client	The NerveCenter software module that enables you to create and manage behavior models as well as monitor and report on network activity. Run the NerveCenter Client program, <code>client.exe</code> , from your Start menu program group (Windows NT) or from the <code>NerveCenter_installation/bin</code> directory.
NerveCenter enterprise trap number	The enterprise-specific MIB object identifier (OID) for NerveCenter is 1.3.6.1.4.1.78. You use this number when creating trap masks to detect Inform messages.
NerveCenter object	A NerveCenter entity that can be part of a behavior model used to manage your network. The following are NerveCenter objects: nodes, property groups and their properties, polls, trap masks, OpC masks, and alarms.
NerveCenter Server	The background engine that handles event correlation and manages the NerveCenter database. Each time you use the NerveCenter Client or Administrator, you must connect to a server. The server can be installed on the same machine as the NerveCenter Client or Administrator applications.
NerveCenter Web Client	The NerveCenter software module that enables you to monitor network activity using Microsoft Internet Explorer 4.0 or Netscape Navigator 4.0. Run the Web Client from your browser by entering the following address: <code>http://servername/NerveCenter</code> See also NerveCenter Web Collector .
NerveCenter Web Collector	If Web server integration was included with your NerveCenter installation, the NerveCenter Web Collector was installed on your machine. The Web Collector

communicates with both the NerveCenter Server and your Web server in order to provide current information about alarms associated with the NerveCenter Server.

NetView

See *IBM Tivoli Systems TME 10 NetView*.

network management platform

NerveCenter supports several network management platforms, and communicates with each using a platform adapter. The platform adapter must be installed and running on the platform host before a connection can be established with NerveCenter.

Following are the platforms that can both provide node information and receive NerveCenter messages, using NerveCenter's OVPA adapter.

- ◆ Hewlett Packard OpenView Network Node Manager
- ◆ IBM Tivoli Systems TME 10 NetView

The following platforms can only receive NerveCenter messages and display those messages in their event or message browser. These use the NerveCenter universal platform adapter:

- ◆ IBM Tivoli Systems TME Enterprise Console
- ◆ Computer Associates Unicenter TNG
- ◆ IBM Tivoli Netcool/OMNIBus

Finally, Hewlett Packard's OpenView IT/Operations (ITO) uses the SEMSOPCA adapter to send and receive IT/O messages. SEMSOPCA is installed when OVPA platform integration is selected during installation.

Network Node Manager

See *Hewlett Packard OpenView Network Node Manager*.

NoAuthNoPriv

Security level that does not require message authentication or encryption services for communication between any two SNMP v3 entities. That means communication between the two SNMP v3 entities communicating with this (i.e. NoAuthNoPriv) security level is not secure.

Communication between two SNMP v3 entities takes place on behalf of a *user* (a uniquely identified entity in the SNMP v3 management domain) in some *context* (a uniquely identified entity for access control generally configured on conventional SNMP v3 agents/nodes). As such, NerveCenter still requires the user name and context for polling.

node

Any device on the network that can be managed. Examples of nodes are servers, workstations, printers, hubs, routers, bridges, and gateways.

When NerveCenter is integrated with a network management platform, you can configure NerveCenter so its node list is populated by the platform. In addition, NerveCenter can be configured to add unknown nodes that send it a trap. You can also populate the list by using NerveCenter's Discovery behavior model, or you can add nodes manually.

See also *managed node*.

node scope Setting for an alarm definition that determines that each alarm instance monitors a node.

See also *alarm scope*.

object identifier, object ID, or OID A unique SNMP name given to each MIB base object, identified by the value of the sysObjectID object in the system group of MIB-II. The name is written as a sequence of integers separated by periods. For example, the sequence 1.3.6.1.2.1.1.1.0 specifies a system description, where 1.3.6.1.2.1.1 specifies the base object system, 1.3.6.1.2.1.1.1 specifies the attribute sysDescr (which has a value), and 1.3.6.1.2.1.1.1.0 specifies an instance (0)

Each object associated with a vendor or type of equipment also has an object identifier.

You can obtain the object identifier for a node in your network by opening its Node Definition window. Select the Query Node tab and then select the **Get** button.

OID See *object identifier, object ID, or OID*.

OpC mask Similar to a NerveCenter trap mask, an OpC mask is used to detect and filter IT/Operations messages. It detects an incoming message, does a preliminary screening for values of interest, and issues a trigger. The OpC mask also gives you the option of creating a trigger function, a Perl subroutine that NerveCenter uses to do more complex filtering on the message.

OVPA (OpenView Platform Adapter) A NerveCenter platform adapter process that resides on a Hewlett Packard OpenView Network Node Manager or IBM Tivoli Systems TME 10 NetView host. The adapter enables communication between the network management platform and NerveCenter.

passwords (SNMP v3) Before NerveCenter can poll SNMP v3 nodes, you must supply the proper passwords for the NerveCenter user. These passwords must be configured on your SNMP v3 agents as well as in NerveCenter Administrator. You need to provide the following passwords:

Authentication - Required for providing authentication services when NerveCenter communicates with the agent using either an AuthNoPriv or AuthPriv security level.

Privacy - Required for providing encryption services when NerveCenter communicates with the agent using an AuthPriv security level.

Depending on the security level you provide in NerveCenter Client for the node corresponding to an SNMP v3 agent, NerveCenter will use an appropriate combination of passwords to provide message authentication and message encryption services. No passwords are required if using NoAuthNoPriv security.

ping	An ICMP echo request sent to a network device that returns an echo reply from the device. ICMP is an error-control protocol that works with the Internet Protocol.
platform adapter	<p>A NerveCenter process that facilitates communication between NerveCenter and a network management platform. The OVPA adapter enables NerveCenter to exchange information with a platform, that is, receive node information and send messages. The universal platform adapter enables NerveCenter to send messages to a platform.</p> <p>See also <i>OVPA (OpenView Platform Adapter)</i> and <i>Universal Platform Adapter (paserver)</i>.</p>
poll	A NerveCenter object that monitors the network for conditions of interest by polling SNMP agents on managed nodes for specific MIB data. The poll compares these values to a user-defined poll condition and trigger expression. If the condition is satisfied, the poll generates a trigger that signals one or more alarms. At least one alarm must be enabled and include a transition that can be triggered by the poll's trigger.
poll condition	<p>Defines the condition to be detected on each node that is tracked. When a poll condition is satisfied, the poll generates a trigger that signals one or more alarms.</p> <p>You can create conditions, such as threshold crossings or rates of change for tracked values, using arithmetic and relational operators. You can string together combinations of conditions using logical (Boolean) operators.</p>
poll rate	The interval (in seconds, minutes, or hours) that a poll waits between requests for node MIB data and evaluation of the associated poll condition.
principal	The person who has access to an SNMP v3 agent.

privacy key	The seed used by the privacy protocol to encrypt messages while communicating with an SNMP v3 entity using AuthPriv security level. The privacy key is described in SNMP v3 specifications.
property	<p>A text string that is a member of one or more property groups. Properties fall into two categories: MIB base objects and user-defined strings. Poll and alarm definitions use properties when determining whether a device should be monitored.</p> <p>The property group associated with a managed node must contain the properties for every MIB base object used in a poll for that node. The property groups shipped with NerveCenter contain the base objects relevant for the group. For example, the Mib-II property group contains properties for each base object in MIB-II. User-defined strings are used to restrict the targeted subset of nodes for a poll or alarm.</p> <p>See also <i>property group</i>.</p>
property group	<p>A collection of one or more text strings called properties. Property groups allow you to categorize nodes into logical or managerial units. The groups can be based on device type, location, priority, supported MIBs, business function, or any other useful characteristic.</p> <p>Each managed node belongs to a property group and, therefore, is associated with all of the group's properties. These properties are used to restrict which polls and alarms monitor the node. Assigning a node to a property group that contains multiple properties allows the node to be targeted by multiple behavior models.</p>
resynchronization (resynch)	<p>When NerveCenter is integrated with a network management platform, NerveCenter issues a Resync command upon start-up. This command updates NerveCenter's entire node list with information from the platform. The update contains all nodes within NerveCenter's subnet filters, if applicable, and includes details about each node's parents.</p> <p>You can manually refresh the NerveCenter node list by selecting the Resync command from the client's Server menu. If this command is not available, the connection to the node source is down.</p> <p>See also <i>synchronization</i>.</p>
scope	See <i>alarm scope</i> .
security level	The use of message authentication and message encryption services for communication between any two SNMP v3 entities. NerveCenter supports the following security levels while communicating with SNMP v3 agents:

	<p>NoAuthNoPriv - Neither message authentication nor message encryption services are used for communication between two SNMP v3 entities. As such, the communication is not secure. NerveCenter requires the user name and context for polling.</p> <p>AuthNoPriv - Message authentication services are used without message encryption for communication between two SNMP v3 entities. This ensures only authenticity of the messages being exchanged between two SNMP v3 entities. The messages are not encrypted.</p> <p>AuthPriv - Both message authentication and message encryption services are used for communication between two SNMP v3 entities. This is the most secure way of communication defined in SNMP v3 specifications at the present time.</p>
SerializedDB	<p>A utility that transfers data between the database being used by NerveCenter and a serialized file. This tool is useful for backing up and restoring database information. Run the SerializedDB program, <code>serializedb.exe</code>, from your Start menu (Windows NT) or from the NerveCenter installation/Bin directory.</p> <p>See also <i>DBWizard</i>.</p>
severity	<p>See <i>alarm severity</i>.</p>
SHA	<p>A secure hash algorithm specified in the Secure Hash Standard (SHS, FIPS PUB 180). This is one of the two algorithms suggested in SNMP v3 specifications for message authentication. This protocol is supported by NerveCenter.</p>
Simple Network Management Protocol (SNMP)	<p>An industry-standard protocol that defines how network management systems exchange information with their managed nodes. Software processes called SNMP agents reside on each managed device and track defined sets of data. A database of network information, called a management information base (MIB), is associated with both the manager and agent. A manager and agent may exist on the same system.</p> <p>SNMP messages allow a management application to set and retrieve agents' managed data. SNMP traps allow an agent to send events to a management application.</p>
smart polling	<p>A NerveCenter feature that reduces the network overhead associated with SNMP management. A poll doesn't solicit data from nodes unless an alarm definition uses the poll's trigger. Even then, the poll is issued to a specific node only when the alarm exists in a state that the poll can trigger. For example, if a behavior model correlates high traffic followed by high error rates, a node is not polled for error rates unless it fulfills the high traffic condition first.</p>
SNMP	<p>See <i>Simple Network Management Protocol (SNMP)</i>.</p>

SNMP trap	An asynchronous notification that an SNMP agent can send to a management application. Traps are identified by a generic number (0–6), an enterprise-specific number, and an enterprise name. Related information data is typically bundled with a trap in structured formats called variable bindings. NerveCenter detects and filters SNMP traps with trap masks.
specific trap number	An SNMP trap number associated with an enterprise MIB. When defining trap masks, generic trap numbers (0-6) indicate the nature of the SNMP trap being reported. In addition, each enterprise, or vendor, can have any number of subtrap numbers, called specific trap numbers, within the category 6 generic trap. Each vendor defines its own number of enterprise traps, their associated specific numbers, their functions, and their variable bindings. See also <i>generic trap number</i> .
state diagram	See <i>alarm state diagram</i> .
subobject	A base object and an instance connected by a period. Examples from MIB-II include ifEntry.3, system.0, and ipForwardEntry.2.
subobject scope	A setting for an alarm definition that determines that each alarm instance monitors a subobject. Subobject scope indicates that conditions for each subobject are tracked separately with separate alarm instances. For example, one alarm instance would track conditions on ifEntry.1, another would track conditions on ifEntry.2, and so on. See also <i>alarm scope</i> .
suppression	NerveCenter provides the following types of suppression as a way to manage unresponsive nodes. Node suppression - When a node fails to respond, it can be suppressed manually or through an alarm action. Normal polling does not occur for the node as long as the node remains suppressed. Poll suppression - By default, NerveCenter polls are suppressible. This means they do not poll nodes that are suppressed. However, there may be specific polls that you want to occur on a node even when it is suppressed. In such a case, you can set the poll to insuppressible. Suppression affects only polling; SNMP traps are still received from a managed node even though it is suppressed.
synchronization	When NerveCenter is integrated with a network management platform, the platform uses a process called synchronization to update NerveCenter whenever

	<p>the platform adds, updates, or deletes nodes. This type of update does not include parent information.</p> <p>See also <i>resynchronization (resynch)</i>.</p>
time ticks	See <i>engine time ticks</i> .
transition	See <i>alarm transition</i> .
trap	See <i>SNMP trap</i> .
trap mask	<p>A NerveCenter object that captures SNMP traps received from managed nodes and fires a trigger that transitions an alarm instance. A mask can detect a standard SNMP trap identified by one of six generic categories, an enterprise-specific trap, and, with the advanced Trigger Function feature, a trap whose contents match user-specified criteria. At least one alarm must be enabled and include a transition that can be triggered by the mask's trigger.</p>
trigger	<p>A flag sent to one or more alarms to indicate that an event has been detected or a condition satisfied. The trigger transitions an alarm from one state to another. The alarm must be enabled and include a transition that can be triggered by this particular trigger.</p> <p>Triggers are generated by polls, trap masks, OpC masks, and the Fire Trigger or Perl Subroutine alarm actions. You specify a trigger using the FireTrigger() function in a poll condition, Perl subroutine, or trap mask trigger function. NerveCenter generates its own built-in triggers, designed to detect unresponsive nodes.</p>
trigger function	<p>A Perl script that you define for a NerveCenter trap mask or OpC mask. The script is called whenever a detected SNMP trap or OpC message matches the mask's data fields.</p> <p>The Perl script issues triggers based upon the contents of the trap's variable bindings. When a suitable trap is detected, NerveCenter executes the trigger function, supplying data from the trap's variable bindings. Your script evaluates the variable-binding contents and conditionally fires triggers or assigns property groups.</p>
trigger generator	<p>A NerveCenter object or action that fires a trigger when a certain condition is detected. The trigger is sent to one or more alarms, where it transitions one or more alarm states.</p> <p>The following are NerveCenter trigger generators: polls, trap masks, OpC masks, Perl subroutines that include the FireTrigger() function, and alarm actions (Send</p>

D

Glossary

Trap, Fire Trigger). NerveCenter generates its own built-in triggers when it detects unresponsive nodes.

Universal Platform Adapter (paserver)

A NerveCenter platform adapter process that resides on IBM Tivoli Systems TME Enterprise Console, Computer Associates Unicenter TNG, or IBM Tivoli Netcool/OMNIbus. The universal platform adapter enables NerveCenter to send Inform messages to those platforms.

user rights

Those with user rights belong to the NerveCenter Users (Windows NT) or ncusers (UNIX) group. They perform such tasks as monitoring NerveCenter alarms, and resetting alarms. They cannot modify the NerveCenter database, for example, by making changes to nodes, property groups, polls, masks, or alarms.

variable bindings

An array of related information that accompanies an SNMP message. The variable bindings are typically defined in standard or vendor-specific MIB definitions (.ASN1 files). The format of each variable binding is defined by SNMP. NerveCenter polls and trap masks obtain variable bindings from the nodes they monitor.

Zero-instance base object

A MIB base object that has only one instance and, therefore, contains a single set of attributes. For example, system is a zero-instance base object because it contains attributes (like sysLocation) that have only one associated value per node. In contrast, ifEntry is a base object with multiple instances. If a node had four ports, the node would have four instances of the ifEntry base object, numbered one through four, and each instance has associated attributes.

Index

A

about NerveCenter Administrator
Administrator port 82
connecting to a server 44
disconnecting from a server 50
server list 47
acknowledging SNMP v3 messages
caused by other clients 161
acknowledging SNMP v3 messages
caused by your Administrator 160
Action Manager error messages 245, 246
Action Router 18
Action Router alarm action 101
Action Router tool 101
activating 113
Active Directory 177
active NerveCenter Server 44
active server 46
administrator 34, 36
Administrator, NerveCenter 24
agent configuration for SNMP v3 151
agent discovery for SNMP v3 154
agent setup for SNMP v3 151, 154
alarm 15, 18
finite state machine 18
IfUpDownStatus example 18
alarm actions 18, 98, 181
Action Router 101
FireTrigger 100
troubleshooting 197
Alarm Filter error messages 251
Alarm Summary window 25
ASN.1
files
characters 283
ASN.1 file 230, 283
troubleshooting 283

ASN.1 files
capitalization 284
hyphens 284
period character 284
table clauses 286
troubleshooting 283
underscore character 284
ASN1 file 22
authentication 136, 137, 155, 157
authentication password 136, 137, 155, 157
auto-classification 141, 142
how NerveCenter classifies nodes 141
maximum classify value 145
when NerveCenter classifies nodes 142
autodelete of nodes 104

B

basic users 34
behavior model 13, 15
objects 15
operation 16
behavior models 14, 66
importing 66
blinking icon 159

C

capabilities, filtering by 103
capability 103
character use in ASN.1 files 283
classification of nodes
how NerveCenter classifies nodes 141
maximum classify value 145
when NerveCenter classifies nodes 142
CLI 28, 86

client command 295
Client, NerveCenter 26
command line 66
command line interface 28, 86, 289
commands
client 295
dbwizard 295
importutil 296
installdb 306
ipsweep 308
mibcomp 310, 314, 325
ncadmin 312
nccmd 312
ncstart 315
ncstop 316
ovpa 317
paserver 321
semsopca 324
trapgen 326
communication port 80, 82, 86
communication ports 80, 84, 86, 88
compiling MIBs
troubleshooting 239
conditions
finding set of network 95
network, detecting 93
persistent network 94
responding to network 98
configuration 47, 80, 82, 84, 86, 88
configuring an Initial user for
discovering an SNMP v3 agent 154
configuring an SNMP v3 agent 151
configuring an SNMP v3 Agent for NerveCenter 151
configuring NerveCenter
Administrator 47, 82
configuring SNMP v3 nodes 136, 137, 146, 155, 157
Connect to Server window 44

- Connecting to a server
 - troubleshooting 51
 - connecting to a server 44, 50
 - managing the server list 47
 - context 136, 137, 155, 157
 - context for SNMP v3 NerveCenter
 - user 157
 - corrective actions 100
 - correlating conditions 93
 - Correlation 13
 - counter 273
 - refreshing 276
 - resetting 275
- D**
- database management
 - DBWizard 210, 212
 - SerializeDB 210, 211, 212
 - UNIX 211
 - Windows 212
 - database, NerveCenter
 - DBWizard 210, 212
 - dbwizard command 295
 - defining
 - nodes, a set of 92
 - deleting a server name 47
 - Deserialize error messages 251
 - detecting condition persistence 94
 - detecting conditions 93
 - digest keys 136, 137, 155, 157
 - disabling 112
 - disconnecting from a server 50
 - Discover Nodes from Traps 121, 126
 - SNMP v3 agents 154
 - discovering an SNMP v3 agent 154
 - discovery 116
 - Discovery and Initialization of SNMP
 - v3 Agents 150
 - Discovery behavior model 102, 119
 - discovery of SNMP v3 agents 150
 - initial user for SNMP v3
 - discovery 154
 - DNS lookup 122, 126
 - documentation
 - conventions 6
 - feedback 8
 - Domain Name Server (DNS) 120
- E**
- Enable Discovery at Startup 122
 - enabling 113
 - environment in UNIX 38, 314
 - error status for SNMP v3 operations 164
 - events 13
- F**
- file format 283
 - troubleshooting ASN.1 files 283, 284, 286, 288
 - file format, ASN.1, troubleshooting 283
 - filtering nodes by capabilities
 - troubleshooting 129
 - finding set of network conditions 95
 - finite state machine 18
 - FireTrigger alarm action 100
 - flat files in UNIX 208
 - Flatfile error messages 252
- G**
- Glossary 339
- H**
- hostname filter 110, 112, 113
 - hostname, filtering by 110
 - hyphens, ASN.1 files 284
- I**
- ICMP 12
 - icon in status bar 159
 - importing 66
 - ImportUtil 66
 - importUtil
 - troubleshooting 78
 - importutil command 296
 - ImportUtil.exe 66
 - imputil.ini 67
 - troubleshooting 78
 - Inform 84
 - inform 18
 - troubleshooting 90
 - Inform NerveCenter error messages 252
- Inform OV error messages 252**
- Inform port 84**
- informing NerveCenter Server 84**
- initial user for SNMP v3 agent 154**
- initialization of SNMP v3 agents 150**
- installdb command 306**
- integration with network management**
- platforms 32
- Internet Control Message Protocol 12**
- Internet Information Server 202**
- IP address 36**
- IP address, filtering by 105**
- IP filter, activating 113**
- IP filter, disabling 112**
- IP filter, enabling 113**
- IP filters**
- troubleshooting 129
- ipsweep command 308**
- K**
- keys 136, 137, 155, 157
 - keys, SNMP v3 137, 155
- L**
- loading MIBs
 - troubleshooting 240
 - log management 194
 - Log to database alarm action 194
 - Log to File alarm action 194
 - Log to File error messages 255, 256
 - log, SNMP v3 operations 159, 160, 161, 163
 - logging 99
 - logging NerveCenter activity 273
 - login rights 34, 35
 - logs 159, 194
 - SNMP v3 operations 159, 160, 161, 163
 - troubleshooting 197
 - looking for a sequence of conditions 96
- M**
- mail actions
 - MS Mail 184
 - SMTP mail 182
 - Management Information Base

- adding or modifying 232, 235, 237
 - shipped with NerveCenter 230
 - troubleshooting ASN.1 files 283
 - management information base 22
 - managing NerveCenter
 - log settings 194
 - poll intervals 147
 - maximum classify value 145
 - maximum SNMP v3 requests 146
 - maximum SNMP v3 requests per cycle 146
 - MIB
 - adding Cisco-Compaq-Bay Networks (Nortel) devices 235
 - adding or modifying 232, 235, 237
 - reloading 237
 - shipped with NerveCenter 230
 - troubleshooting ASN.1 files 283
 - MIB definitions
 - adding or removing 232
 - MIB definitions from other sources 232
 - MIB files
 - ASN1 file 22
 - MibComp compiler 22
 - MibComp.txt 22
 - NerveCtr.mib 22
 - MibComp 22
 - mibcomp 232, 233
 - mibcomp command 310, 314, 325
 - mibcomp.exe 230, 232, 235, 237
 - MibComp.txt 22
 - mibcomp.txt 230, 232, 235, 237
 - MIBs 229
 - compiling 235
 - troubleshooting 239
 - Microsoft Access 208
 - Microsoft Exchange profiles 184
 - Microsoft mail 184
 - Microsoft mail notifications
 - troubleshooting 197
 - Microsoft SQL Server 208
 - MS Mail 184
 - multiple servers 46
- N**
- ncadmin command 312
 - NCAAdmin Configuration window 47
 - nccmd command 312
 - NCContext 136, 137, 155, 157
 - ncstart command 315
 - ncstop command 316
 - NCUser 136, 137, 155, 157
 - NerveCenter
 - Action Router tool 101
 - administration 33
 - Administrator 24
 - Client 26
 - components 21
 - database 21
 - nodes managing 14, 92
 - Server 21
 - servers, multiple 31
 - NerveCenter Administrator
 - connecting to a NerveCenter Server 44
 - server port 82
 - starting 51
 - starting in UNIX 42
 - starting in Windows 43
 - NerveCenter Administrator window 45
 - NerveCenter Client 25
 - Alarm Summary window 25
 - login rights 35
 - serve port 83
 - NerveCenter database 207, 209
 - backing up 213
 - formats 208
 - restoring 217
 - transferring data 221
 - troubleshooting 227
 - using the command line 219
 - NerveCenter error messages 243
 - NerveCenter inform port 72, 84, 301
 - NerveCenter installation error messages 266
 - NerveCenter MIB
 - adding or modifying 232, 235, 237
 - shipped with NerveCenter 230
 - troubleshooting ASN.1 files 283
 - NerveCenter MIB definitions 230
 - NerveCenter OpenView Platform Adapter (OVPA) 117
 - NerveCenter Server
 - active 44, 46
 - as a process 188
 - as a Windows service 185
 - as an Inform recipient 84
 - configuration from the command line 66
 - connecting 44
 - connecting to more than one 46
 - connection port 80
 - defined 44
 - disconnecting 50
 - running on UNIX 38
 - starting manually 38, 314
 - status 48
 - troubleshooting 40, 51, 78, 90
 - Windows 39
 - NerveCenter user security for SNMP v3 136, 137, 155, 157
 - NerveCenter utilities
 - ImportUtil 66
 - Trapgen 55
 - Traprcv 55
 - NerveCenter Web Client 27
 - NerveCenter Web Collector
 - on UNIX 200
 - on Windows 200
 - NerveCtr.mib 22, 230, 232, 235, 237
 - nervectr.mib 230
 - network conditions
 - finding set of 95
 - persistent 94
 - responding to 98
 - network conditions, detecting 93
 - network management platform 69, 102, 103, 117, 298
 - as a node source 124
 - node source 117
 - node source filters 103, 104
 - resynchronization 124
 - synchronization with 124
 - troubleshooting 129
 - node 15
 - changing a node's name 125
 - deleting manually 127
 - node classification 141, 142
 - maximum classify value 145
 - node data
 - source 102
 - node data source 117
 - node list
 - adding and deleting manually 127

- defined 102
 - filtering 103
 - filtering by capabilities 103
 - filtering by hostname 110
 - filtering by IP address 105
 - filtering by system object identifier 104
 - maintaining 123
 - populating 115
 - populating manually 122
 - populating using a network management platform 117
 - populating using the Discovery behavior model 119
 - troubleshooting 129
 - node source 117
 - node source - server status
 - filtering by object ID 104
 - filtering by wanted capability 103
 - processing unknown traps 113
 - system object ID filter 104
 - wanted capability filter 103
 - nodes
 - autodelete 127
 - defining a set of 92
 - discovered from traps 125
 - hostname filter 110
 - NerveCenter managing 14, 92
 - notification 99
 - notification action
 - MS Mail 184
 - page 190, 192
 - SMTP mail 182
 - NSMG MIB definition 230
- O**
- object ID 104
 - online knowledgebase 9
 - OpC Manager error messages 256
 - OpenView 266
 - OpenView configuration error messages 269
 - Operations log 159
 - signing for errors caused by other clients 161
 - signing for errors caused by your Administrator 160
 - viewing the log 163
 - operations log 159, 160, 161, 163
 - overview of NerveCenter SNMP v3 support 134, 136, 137, 150, 151, 154, 155, 157
 - configurations 146
 - ovpa command 317
- P**
- PA Resync Manager error messages 258
 - page actions 190, 192
 - paging
 - setting dialing properties on UNIX 192
 - setting properties on Windows 190
 - troubleshooting 197
 - paserver command 321
 - password 44, 136, 137, 155, 157
 - passwords 155
 - Perl 18
 - Perl subroutine 17, 18
 - poll 15
 - Poll Manager error messages 257
 - ports 80, 82, 84, 86, 88
 - power users 34
 - privacy 136, 137, 155, 157
 - privacy password 136, 137, 155, 157
 - processing traps from unknown nodes 113
 - properties 92
 - property 15, 17
 - property group 15, 17
 - Protocol Manager error messages 257
- R**
- red icon in status bar 159
 - requests max for SNMP v3 nodes 146
 - resetting trace counters 275
 - responding to network conditions 98
 - Resync 124
 - role in network management strategy 29
- S**
- security 136, 137, 155, 157, 171
 - UNIX 172
 - Windows 172
 - security for SNMP v3 136, 137, 155, 157
 - semsopca command 324
 - serial number
 - adding 63
 - deleting 64
 - rules for adding/deleting 65
 - serial numbers
 - purpose 62
 - SerializeDB 207, 210, 211, 212
 - application 217
 - troubleshooting 227
 - SerializeDB application 214
 - server list 47
 - deleting a name 47, 82
 - managing 47, 82
 - Server Manager error messages 260
 - server name 82
 - Server Name list 44, 51
 - server port 82
 - server ports
 - CLI 86
 - Inform 84
 - server communication 80
 - SNMP 88
 - server status 86
 - CLI port configuring the Administrator port 82
 - configuring the server list 47
 - configuring the Server port 80
 - connecting 44
 - disconnecting 50
 - importing 66
 - managing the server list 47
 - Server Status window 36, 48, 209
 - servers, multiple NerveCenter 31
 - setting the maximum SNMP v3 requests per cycle 146
 - setting up an SNMP v3 agent 151, 154
 - severity 25
 - Simple Network Management Protocol 12
 - smart polling 93
 - SMTP mail 182
 - SMTP mail notifications

- troubleshooting 197
 - SNMP 12, 13
 - SNMP Agent
 - disabling 169
 - SNMP Agent tab 167
 - SNMP master agent
 - configuring 167
 - SNMP ports 88
 - SNMP settings 88, 134, 147, 149, 150
 - digest key passwords 155
 - maximum SNMP v3 requests 146
 - node classification 141, 142, 145
 - security 155
 - user name and context 157
 - SNMP sub agent
 - configuring 170
 - SNMP trap source 54
 - SNMP v3 134
 - agent discovery 154
 - agent setup 151
 - auto-classification 141, 142, 145
 - classification 145
 - configuration 146
 - configuring trap source 56
 - digest keys 137
 - discovery of agents 150
 - initialization of agents 150
 - operations log 159, 160, 161, 163
 - overview 134
 - security 136, 137, 155, 157
 - SNMP v3 support 134, 150
 - configuring an agent 151
 - digest key passwords 155
 - digest keys and passwords 137
 - discovering an agent 154
 - error status 164
 - maximum requests per cycle 146
 - node classification 141, 142, 145
 - operations log 159, 160, 161, 163
 - security 136, 155
 - trap source 54
 - user name and context 157
 - standalone operation 30
 - state transitions *See* transitions
 - status bar icon 159
 - status, error for SNMP v3 operations 164
 - subnet filter
 - automatic criteria 107
 - manual criteria 108
 - system object ID 104
 - system object identifier, filtering by 104
 - system Object Identifiers 118
- T**
- table clauses, ASN.1 files 286
 - Tech Support Web 36
 - technical support 8
 - contacting 8
 - educational services 8
 - professional services 8
 - tools
 - Action Router tool 101
 - trace counter 273
 - refreshing the counters 276
 - resetting 275
 - tabbed pages 274, 277, 278, 279, 280, 281, 282
 - tracing NerveCenter operations 273
 - tracing NerveCenter operations 273
 - tabbed pages 274, 277, 278, 279, 280, 281, 282
 - transitions
 - causing 100
 - trap 113
 - changing the trap source 56
 - processing unknown nodes 113
 - Trap Manager error messages 265
 - trap mask 15
 - trap source 54
 - Trapgen 55
 - trapgen command 326
 - Traprcv 55
 - traps from unknown nodes
 - processing 113
 - trigger 15
 - Troubleshooting 271
 - troubleshooting 273
 - troubleshooting ASN.1 files 283, 284, 286, 288
- U**
- underscore character 284
 - understanding NerveCenter 11
- UNIX** 38, 42
 - paging 192
 - security 172
 - troubleshooting 40, 51
- UNIX database 211
- UNIX security 171
- unknown nodes 125
- user context for SNMP v3 157
- user name for SNMP v3 157
- user name MD5 136, 137, 155, 157
- user name SHA-1 136, 137, 155, 157
- users
 - administrator 34
 - basic 34
 - power 34
- V**
- v3messages.log 159, 163
 - vendor-specific MIBs 230, 231
 - viewing the SNMP v3 Operations log 163
- W**
- wanted capability 103
 - Web Client 27
 - Web Collector 27
 - connection from a Web server 201
 - starting and stopping 199
 - web integration 199
 - Web Server integration 199, 201
 - Web-based monitoring 28
 - Windows 39, 43
 - paging 190
 - security 172
 - troubleshooting 40
 - Windows database 212
 - DBWizard 210, 212
 - Windows domain controller
 - security 175
 - Windows security 171
 - Windows workstation or server
 - security 173

